

Machine Controller MP2000 Series

Machine Controller System

SETUP MANUAL

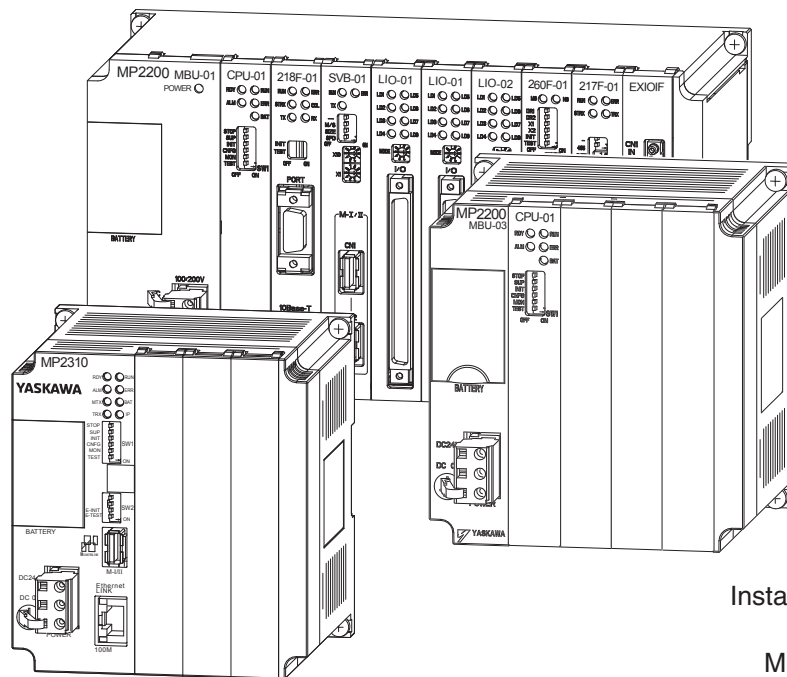

System Configuration

1

Installation and Connections

2

Machine Controller Setup

3

Creating User Programs

4

Debugging Programs

5

Security

6

Controller Installation and
Operating Conditions

AppA

Motion Parameters

AppB

Copyright © 2015 YASKAWA ELECTRIC CORPORATION

All rights reserved. No part of this publication may be reproduced, stored in a retrieval system, or transmitted, in any form, or by any means, mechanical, electronic, photocopying, recording, or otherwise, without the prior written permission of Yaskawa. No patent liability is assumed with respect to the use of the information contained herein. Moreover, because Yaskawa is constantly striving to improve its high-quality products, the information contained in this manual is subject to change without notice. Every precaution has been taken in the preparation of this manual. Nevertheless, Yaskawa assumes no responsibility for errors or omissions. Neither is any liability assumed for damages resulting from the use of the information contained in this publication.

About this Manual

This manual describes the procedures that are required to use the Machine Controller, from installation and connections to programming, trial operation, and debugging.

Read this manual carefully to ensure the correct usage of the Machine Controller and apply the Machine Controller to control your manufacturing system.

Keep this manual in a safe place so that it can be referred to whenever necessary.

Outline of Manual

The contents of the chapters of this manual are described in the following table. Refer to the chapters of this manual as required for your application.

Chapter	Chapter Title	Contents
1	System Configuration	Describes the combinations of Units and Modules in MP2000-series Machine Controllers and provides system configuration examples.
2	Installation and Connections	Describes the installation and connections of Machine Controllers.
3	Machine Controller Setup	Provides the procedures for setting up a Machine Controller using the MPE720.
4	Creating User Programs	Provides the types of user programs and describes how to create and write them to the Controller.
5	Debugging Programs	Describes how to debug programs and how to adjust the operation of the machine.
6	Security	Describes the security features.
Appendix A	Controller Installation and Operating Conditions	Describes conditions when the MP2000-series Machine Controllers are used.
Appendix B	Motion Parameters	Provides the lists of the motion parameters.

Related Manuals

The following table lists the manuals that are related to the MP2000-series Machine Controllers. Refer to these manuals as required.

Be aware of all product specifications and restrictions to product application before you attempt to use any product.

Category	Manual Name	Manual Number	Contents
Basic functionality	Machine Controller MP2000 Series Machine Controller System Setup Manual	SIEP C880732 14 (This manual)	Describes the functions of the MP2000-series Machine Controllers and the procedures that are required to use the Machine Controller, from installation and connections to settings, programming, trial operation, and debugging.
	Machine Controller MP210□/MP210□M User's Manual, Design and Maintenance	SIEP C880700 01	Describes the functions, specifications, setup procedures, and operating methods of the MP210□/MP210□M.
	Machine Controller MP2101T/MP2101TM User's Manual, Design and Maintenance	SIEP C880712 00	Describes the functions, specifications, setup procedures, and operating methods of the MP2101T/MP2101TM.
	Machine Controller MP2200 User's Manual	SIEP C880700 14	Describes the functions, specifications, setup procedures, and operating methods of the MP2200.
	Machine Controller MP2300 Basic Module User's Manual	SIEP C880700 03	Describes the functions, specifications, setup procedures, and operating methods of the MP2300.
	Machine Controller MP2300S Basic Module User's Manual	SIEP C880732 00	Describes the functions, specifications, setup procedures, and operating methods of the MP2300S.
	Machine Controller MP2310 Basic Module User's Manual	SIEP C880732 01	Describes the functions, specifications, setup procedures, and operating methods of the MP2310.
	Machine Controller MP2400 User's Manual	SIEP C880742 00	Describes the functions, specifications, setup procedures, and operating methods of the MP2400.
	Machine Controller MP2000 Series Troubleshooting Manual	SIEP C880700 40	Describes troubleshooting an MP2000-series Machine Controller.
Communications functionality	Machine Controller MP2000 Series Communication Module User's Manual	SIEP C880700 04	Provides information on the Communications Modules that can be connected to an MP2000-series Machine Controller and describes the communications methods.
	Machine Controller MP2300S/MP2310/MP2400 Basic Module Supplement for Ethernet Communications	SIEP C880700 37	Describes a specific method of communications between the MP2300S, MP2310, or MP2400 Machine Controllers and Ethernet-connected remote equipment, such as PLCs and Windows computers.
	Machine Controller MP2000 Series Ethernet Communication Troubleshooting Manual	SIEP C880700 45	Describes the methods for troubleshooting the trouble that occurs while using devices that are connected to an MP2000 Series Machine Controller via Ethernet.
	Machine Controller MP2000 Series 2621F-01 FL-net Communication Module User's Manual	SIEP C880700 36	Describes the specifications and communications methods for the FL-net Communications Module that can be connected to an MP2000-series Machine Controller.

Continued on next page.

Continued from previous page.

Category	Manual Name	Manual Number	Contents
Communications functionality	Machine Controller MP2000 Series 263IF-01 EtherNet/IP Communication Module User's Manual	SIEP C880700 39	Describes the specifications and communications methods for the EtherNet/IP Communications Module that can be connected to an MP2000-series Machine Controller.
	Machine Controller MP2000 Series EtherCAT Module 264IF-01 USER'S MANUAL	SIEP C880700 42	Describes the specifications and communications methods for the EtherCAT Module that can be connected to an MP2000-series Machine Controller.
	Machine Controller MP2000 Series 265IF-01 CompoNet Module USER'S MANUAL	SIEP C880700 44	Describes the specifications and communications methods for the CompoNet Module that can be connected to an MP2000-series Machine Controller.
	Machine Controller MP2000 Series 266IF-02 PROFINET Device Module USER'S MANUAL	SIEP C880700 48	Describes the specifications and communications methods for the PROFINET Device Module that can be connected to an MP2000-series Machine Controller.
	Machine Controller MP2000 Series CC-Link IE Field Slave Module 269IF-01 USER'S MANUAL	SIEP C880700 49	Describes the specifications and communications methods for the CC-Link IE Field Slave Module that can be connected to an MP2000-series Machine Controller.
	Machine Controller MP2000 Series 267IF-01 CC-Link Master Module USER'S MANUAL	SIEP 880712 01	Describes the specifications and communications methods for the CC-Link Master Module that can be connected to an MP2000-series Machine Controller.
Motion control functionality	Machine Controller MP2000 Series SVA-01 Motion Module User's Manual	SIEP C880700 32	Describes the functions, specifications, and operating methods of the MP2000-series SVA-01 Motion Module.
	Machine Controller MP2000 Series Built-in SVB/SVB-01 Motion Module User's Manual	SIEP C880700 33	Describes the functions, specifications, and operating methods of the MP2000-series Motion Module (built-in Function Modules: SVB, SVB-01, and SVR).
	Machine Controller MP2000 Series SVC-01 Motion Module User's Manual	SIEP C880700 41	Describes the functions, specifications, and operating methods of the MP2000-series SVC-01 Motion Module.
	Machine Controller MP2000 Series Pulse Output Motion Module PO-01 User's Manual	SIEP C880700 28	Describes the functions, specifications, and operating methods of the MP2000-series PO-01 Motion Module.
	Machine Controller MP2000 Series MPU-01 Multiple-CPU Module USER'S MANUAL	SIEP C880781 05	Describes the functions, specifications, and operating methods of the MP2000-series MPU-01 Multiple-CPU Module.
Programming	Machine Controller MP900/MP2000 Series User's Manual, Ladder Programming	SIEZ-C887-1.2	Describes the instructions used in MP2000 ladder programming.
	Machine Controller MP2000 Series User's Manual for Motion Programming	SIEP C880700 38	Describes the instructions used in MP2000 motion programming.
	Machine Controller MP900/MP2000 Series New Ladder Editor Programming Manual	SIEZ-C887-13.1	Describes the programming instructions of the New Ladder Editor, which assists MP900/MP2000-series design and maintenance.
	Machine Controller MP900/MP2000 Series New Ladder Editor User's Manual	SIEZ-C887-13.2	Describes the operating methods of the New Ladder Editor, which assists MP900/MP2000-series design and maintenance.

Continued on next page.

Continued from previous page.

Category	Manual Name	Manual Number	Contents
Engineering Tool	Machine Controller MP2000/MP3000 Series MPLoader Version 4 User's Manual	SIEP C880761 01	Describes how to install and operate the MPLoader.
	Machine Controller MP2000/MP3000 Series MPLoad Maker Version 4 User's Manual	SIEP C880761 02	Describes how to install and operate the MPLoad Maker.
	Machine Controller MP2000/MP3000 Series Engineering Tool MPE720 Version 7 User's Manual	SIEP C880761 03	Describes how to operate MPE720 version 7.
I/O Modules	Machine Controller MP2000 Series I/O Module User's Manual	SIEP C880700 34	Describes the functions, specifications, and operating methods of the LIO-01, LIO-02, LIO-04, LIO-05, LIO-06, and DO-01 I/O Modules for MP2000-series Machine Controllers.
	Machine Controller MP2000 Series Analog Input/Analog Output Module AI-01/AO-01 User's Manual	SIEP C880700 26	Describes the functions, specifications, and operating methods of the AI-01 and AO-01 I/O Modules for MP2000-series Machine Controllers.
	Machine Controller MP2000 Series Counter Module CNTR-01 User's Manual	SIEP C880700 27	Describes the functions, specifications, and operating methods of the CNTR-01 Counter Module for MP2000-series Machine Controllers.
MECHATROLINK I/O	MECHATROLINK-III Compatible I/O Module User's Manual	SIEP C880781 04	Describes the functions, specifications, operating methods, and MECHATROLINK-III communications for the Remote I/O Modules for MP2000/MP3000-series Machine Controllers.
	Machine Controller MP900/MP2000 Series Distributed I/O Module User's Manual, MECHATROLINK System	SIE-C887-5.1	Describes MECHATROLINK distributed I/O for MP900/MP2000-series Machine Controllers.
	Machine Controller MP2000/MP3000 Series Distributed I/O Module User's Manual MECHATROLINK-II	SIEP C880732 13	Describes MECHATROLINK-II distributed I/O for MP2000/MP3000-series Machine Controllers.
	Machine Controller MP2000/MP3000 Series MECHATROLINK-III Compatible I/O Module Product Manual	SIEP C880732 16	Describes MECHATROLINK-III I/O Module for MP2000/MP3000-series Machine Controllers.

Using this Manual

◆ Basic Terms

Unless otherwise specified, the following definitions are used:

Basic Terms	Meaning
Machine Controller	A generic name for the following MP2000 Machine Controllers: MP2200, MP2300, MP2310, MP2300S, and MP2400. (The MP2200 and MP2310 are used as typical examples in this manual.)
MPE720	The Engineering Tool or a personal computer running the Engineering Tool
PLC	A Programmable Logic Controller
Motion Control Function Modules	The Function Modules in the Motion Modules and the Function Modules in the SVA-01, SVB/SVB-01, or SVC-01 built into the CPU Modules.
Communications Function Modules	The Function Modules in the Communications Modules and the Function Modules in the 218IFD built into the CPU Modules.

◆ Manual Configuration

This manual is structured according to the following flow of setup procedures.

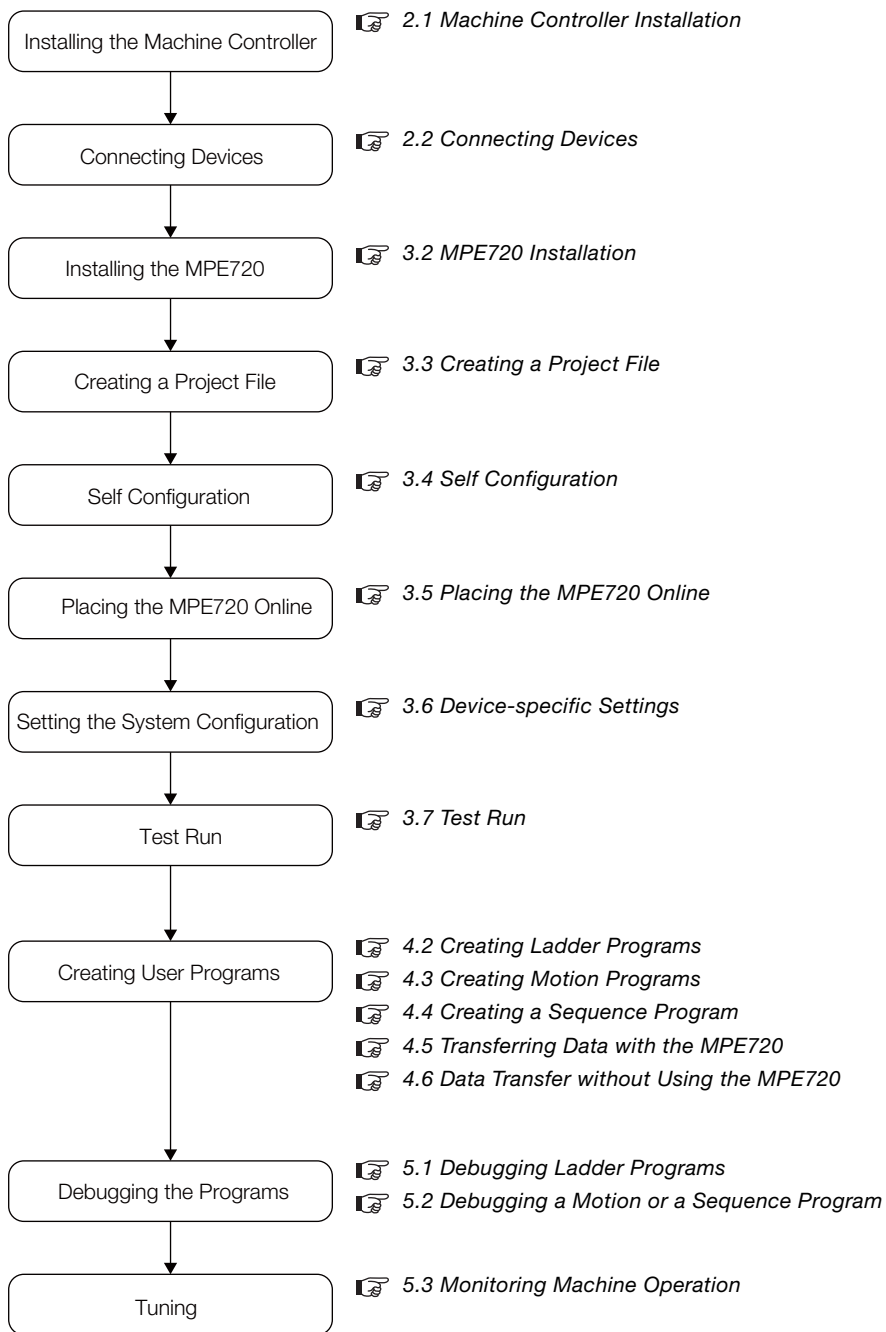

◆ MPE720 Engineering Tool Version Number

In this manual, the operation of MPE720 is described using screen captures of MPE720 version 7. For this reason, the screen captures and some descriptions may differ for MPE720 version 6.

◆ Indication of Reverse Signals

In this manual, the names of reverse signals (ones that are valid when low) are written with a forward slash (/) before the signal name, as shown in the following example:

Notation Examples

- $\overline{S-ON} = /S-ON$
- $\overline{P-CON} = /P-CON$

◆ Terms Used to Describe “Torque”

Although the term “torque” is commonly used when describing rotary Servomotors and “force” is used when describing linear Servomotors, this manual uses “torque” when describing either one (excluding parameter names).

◆ Copyrights

- MECHATROLINK is a trademark of the MECHATROLINK Members Association.
- DeviceNet is a registered trademark of the ODVA (Open DeviceNet Venders Association).
- PROFIBUS is a trademark of the PROFIBUS User Organization.
- Ethernet is a registered trademark of the Xerox Corporation.
- Other product names and company names are the trademarks or registered trademarks of the respective company. “TM” and the ® mark do not appear with product or company names in this manual.

◆ Visual Aids

The following aids are used to indicate certain types of information for easier reference.



Important

Indicates precautions or restrictions that must be observed.

Indicates alarm displays and other precautions that will not result in machine damage.



Term

Indicates definitions of difficult terms or terms that have not been previously explained in this manual.

Example

Indicates operating or setting examples.

Information

Indicates supplemental information to deepen understanding or useful information.

Safety Precautions

◆ Safety Information

To prevent personal injury and equipment damage in advance, the following signal words are used to indicate safety precautions in this document. The signal words are used to classify the hazards and the degree of damage or injury that may occur if a product is used incorrectly. Information marked as shown below is important for safety. Always read this information and heed the precautions that are provided.



DANGER

- Indicates precautions that, if not heeded, are likely to result in loss of life, serious injury, or fire.



WARNING

- Indicates precautions that, if not heeded, could result in loss of life, serious injury, or fire.



CAUTION

- Indicates precautions that, if not heeded, could result in relatively serious or minor injury, or in fire.

NOTICE

- Indicates precautions that, if not heeded, could result in property damage.

◆ Safety Precautions That Must Always Be Observed

■ General Precautions



WARNING

- The installation must be suitable and it must be performed only by an experienced technician.
There is a risk of electrical shock or injury.
- Before connecting the machine and starting operation, make sure that an emergency stop procedure has been provided and is working correctly.
There is a risk of injury.
- Do not approach the machine after a momentary interruption to the power supply. When power is restored, the product and the device connected to it may start operation suddenly. Provide safety measures in advance to ensure human safety when operation restarts.
There is a risk of injury.
- Do not touch anything inside the product.
There is a risk of electrical shock.
- Do not remove the front cover, cables, connector, or options while power is being supplied.
There is a risk of electrical shock, malfunction, or damage.
- Do not damage, pull on, apply excessive force to, place heavy objects on, or pinch the cables.
There is a risk of electrical shock, operational failure of the product, or burning.
- Do not attempt to modify the product in any way.
There is a risk of injury or device damage.

■ Storage and Transportation Precautions



CAUTION

- Hold onto the main body of the product when transporting it.
Holding the cables or connectors may damage them or result in injury.
- Do not overload the product during transportation. (Follow all instructions.)
There is a risk of injury or an accident.
- Never subject the product to an atmosphere containing halogen (fluorine, chlorine, bromine, or iodine) during transportation.
There is a risk of malfunction or damage.
- If disinfectants or insecticides must be used to treat packing materials such as wooden frames, pallets, or plywood, the packing materials must be treated before the product is packaged, and methods other than fumigation must be used.
Example: Heat treatment, where materials are kiln-dried to a core temperature of 56°C for 30 minutes or more.
If the electronic products, which include stand-alone products and products installed in machines, are packed with fumigated wooden materials, the electrical components may be greatly damaged by the gases or fumes resulting from the fumigation process. In particular, disinfectants containing halogen, which includes chlorine, fluorine, bromine, or iodine can contribute to the erosion of the capacitors.

NOTICE

- Do not store the product in any of the following locations.
 - Locations that are subject to direct sunlight
 - Locations that are subject to ambient temperatures that exceed product specifications
 - Locations that are subject to relative humidities that exceed product specifications
 - Locations that are subject to condensation as the result of extreme changes in temperature
 - Locations that are subject to corrosive or flammable gases
 - Locations that are near flammable materials
 - Locations that are subject to dust, salts, or iron powder
 - Locations that are subject to water, oil, or chemicals
 - Locations that are subject to vibration or shock that exceeds product specificationsIf you store the product in any of the above locations, the product may fail or be damaged.

■ Installation Precautions



CAUTION

- **Never install the product in an atmosphere containing halogen (fluorine, chlorine, bromine, or iodine).**
There is a risk of malfunction or damage.
- **Do not step on the product or place heavy objects on the product.**
There is a risk of injury or an accident.
- **Do not block the air exhaust ports on the product. Do not allow foreign objects to enter the product.**
There is a risk of internal element deterioration, malfunction, or fire.
- **Always mount the product in the specified orientation.**
There is a risk of malfunction.
- **Leave the specified amount of space between the product, and the interior surface of the control panel and other devices.**
There is a risk of fire or malfunction.
- **Do not subject the product to strong shock.**
There is a risk of malfunction.
- **Suitable battery installation must be performed and it must be performed only by an experienced technician.**
There is a risk of electrical shock, injury, or device damage.
- **Do not touch the electrodes when installing the Battery.**
Static electricity may damage the electrodes.

NOTICE

- **Do not install the product in any of the following locations.**
 - Locations that are subject to direct sunlight
 - Locations that are subject to ambient temperatures that exceed product specifications
 - Locations that are subject to relative humidities that exceed product specifications
 - Locations that are subject to condensation as the result of extreme changes in temperature
 - Locations that are subject to corrosive or flammable gases
 - Locations that are near flammable materials
 - Locations that are subject to dust, salts, or iron powder
 - Locations that are subject to water, oil, or chemicals
 - Locations that are subject to vibration or shock that exceeds product specifications
 - Locations near devices that generate strong magnetic fields
 - Locations that are subject to radiation
- If you install the product in any of the above locations, the product may fail or be damaged.

■ Wiring Precautions

CAUTION

- **Do not change any wiring while power is being supplied.**
There is a risk of electrical shock, injury, or machine damage.
- **Check the wiring to be sure it has been performed correctly.**
There is a risk of motor run-away, injury, or accidents.
- **Always use a power supply of the specified voltage.**
There is a risk of fire or accident.
- **In places with poor power supply conditions, ensure that the input power is supplied within the specified voltage range.**
There is a risk of device damage.
- **Install breakers and other safety measures to provide protection against shorts in external wiring.**
There is a risk of fire.
- **Provide sufficient shielding when using the product in the following locations.**
 - Locations that are subject to noise, such as from static electricity
 - Locations that are subject to strong electromagnetic or magnetic fields
 - Locations that are subject to radiation
 - Locations that are near power linesThere is a risk of device damage.
- **Configure the circuits to turn ON the power supply to the CPU Unit/CPU Module before the 24-V I/O power supply.**
If the power supply to the CPU Unit/CPU Module is turned ON after the external power supply, e.g., the 24-V I/O power supply, the outputs from the CPU Unit/CPU Module may momentarily turn ON when the power supply to the CPU Unit/CPU Module turns ON. This can result in unexpected operation that may cause injury or device damage.
- **Provide emergency stop circuits, interlock circuits, limit circuits, and any other required safety measures in control circuits outside of the product.**
There is a risk of injury or device damage.
- **If you use MECHATROLINK I/O Modules, use the establishment of MECHATROLINK communications as an interlock output condition.**
There is a risk of device damage.
- **Connect the Battery with the correct polarity.**
There is a risk of battery damage or explosion.
- **Select the I/O signal wires for external wiring to connect the product to external devices based on the following criteria:**
 - Mechanical strength
 - Noise interference
 - Wiring distance
 - Signal voltage
- **Separate the I/O signal cables for control circuits from the power cables both inside and outside the control panel to reduce the influence of noise from the power cables.**
If the I/O signal lines and power lines are not separated properly, malfunction may occur.

Example of Separated Cables

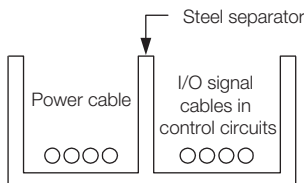

■ Operation Precautions

CAUTION

- Follow the procedures and instructions in the user's manuals for the relevant products to perform normal operation and trial operation.
Operating mistakes while the Servomotor and machine are connected may damage the machine or even cause accidents resulting in injury or death.
- Implement interlock signals and other safety circuits external to the product to ensure safety in the overall system even if the following conditions occur.
 - product failure or errors caused by external factors
 - Shutdown of operation due to product detection of an error in self-diagnosis and the subsequent turning OFF or holding of output signals
 - Holding of the ON or OFF status of outputs from the product due to fusing or burning of output relays or damage to output transistors
 - Voltage drops from overloads or short-circuits in the 24-V output from the product and the subsequent inability to output signals
 - Unexpected outputs due to errors in the power supply, I/O, or memory that cannot be detected by the product through self-diagnosis.
There is a risk of injury, device damage, or burning.
- Observe the setting methods that are given in the manual of the Motion Control Function Modules to be used for the following parameters.
 - Parameters for absolute position detection when the axis type is set to a finite-length axis
 - Parameters for simple absolute infinite-length position control when the axis type is set to an infinite-length axisIf any other methods are used, offset in the current position when the power supply is turned OFF and ON again may result in device damage.
- OL□□□48 (Zero Point Position Offset in Machine Coordinate System) is always valid when the axis type is set to a finite-length axis. Do not change the setting of OL□□□48 while the product is operating.
There is a risk of machine damage or an accident.

■ Maintenance and Inspection Precautions

CAUTION

- Do not attempt to disassemble or repair the product.
There is a risk of electrical shock, injury, or device damage.
- Do not change any wiring while power is being supplied.
There is a risk of electrical shock, injury, or device damage.
- Suitable battery replacement must be performed and it must be performed only by an experienced technician.
There is a risk of electrical shock, injury, or device damage.
- Replace the Battery only while power is supplied to the product.
Replacing the Battery while the power supply to the product is turned OFF may result in loss of the data stored in memory in the product.
- Do not touch the electrodes when replacing the Battery.
Static electricity may damage the electrodes.
- Do not forget to perform the following tasks when you replace the CPU Unit/CPU Module:
 - Back up all programs and parameters from the CPU Unit/CPU Module that is being replaced.
 - Transfer all saved programs and parameters to the new CPU Unit/CPU Module.If you operate the CPU Unit/CPU Module without transferring this data, unexpected operation may occur. There is a risk of injury or device damage.

■ Disposal Precautions

- Correctly discard the product and used batteries as stipulated by regional, local, and municipal laws and regulations. Be sure to include these contents in all labelling and warning notifications on the final product as necessary.



■ Other General Precautions

- Figures provided in this manual are typical examples or conceptual representations. There may be differences between them and actual wiring, circuits, and products.
- The products shown in illustrations in this manual are sometimes shown with their covers or protective guards removed to illustrate detail. Always replace all covers and protective guards before you use the product.
- If you need a new copy of this document because it has been lost or damaged, contact your nearest Yaskawa representative or one of the offices listed on the back of this manual.
- This manual is subject to change without notice for product improvements, specifications changes, and improvements to the manual itself.
We will update the document number of the manual and issue revisions when changes are made.
- Any and all quality guarantees provided by Yaskawa are null and void if the customer modifies the product in any way. Yaskawa disavows any responsibility for damages or losses that are caused by modified products.

Warranty

◆ Details of Warranty

■ Warranty Period

The warranty period for a product that was purchased (hereinafter called “delivered product”) is one year from the time of delivery to the location specified by the customer or 18 months from the time of shipment from the Yaskawa factory, whichever is sooner.

■ Warranty Scope

Yaskawa shall replace or repair a defective product free of charge if a defect attributable to Yaskawa occurs during the warranty period above. This warranty does not cover defects caused by the delivered product reaching the end of its service life and replacement of parts that require replacement or that have a limited service life.

This warranty does not cover failures that result from any of the following causes.

- Improper handling, abuse, or use in unsuitable conditions or in environments not described in product catalogs or manuals, or in any separately agreed-upon specifications
- Causes not attributable to the delivered product itself
- Modifications or repairs not performed by Yaskawa
- Abuse of the delivered product in a manner in which it was not originally intended
- Causes that were not foreseeable with the scientific and technological understanding at the time of shipment from Yaskawa
- Events for which Yaskawa is not responsible, such as natural or human-made disasters

◆ Limitations of Liability

- Yaskawa shall in no event be responsible for any damage or loss of opportunity to the customer that arises due to failure of the delivered product.
- Yaskawa shall not be responsible for any programs (including parameter settings) or the results of program execution of the programs provided by the user or by a third party for use with programmable Yaskawa products.
- The information described in product catalogs or manuals is provided for the purpose of the customer purchasing the appropriate product for the intended application. The use thereof does not guarantee that there are no infringements of intellectual property rights or other proprietary rights of Yaskawa or third parties, nor does it construe a license.
- Yaskawa shall not be responsible for any damage arising from infringements of intellectual property rights or other proprietary rights of third parties as a result of using the information described in catalogs or manuals.

◆ Suitability for Use

- It is the customer's responsibility to confirm conformity with any standards, codes, or regulations that apply if the Yaskawa product is used in combination with any other products.
- The customer must confirm that the Yaskawa product is suitable for the systems, machines, and equipment used by the customer.
- Consult with Yaskawa to determine whether use in the following applications is acceptable. If use in the application is acceptable, use the product with extra allowance in ratings and specifications, and provide safety measures to minimize hazards in the event of failure.
 - Outdoor use, use involving potential chemical contamination or electrical interference, or use in conditions or environments not described in product catalogs or manuals
 - Nuclear energy control systems, combustion systems, railroad systems, aviation systems, vehicle systems, medical equipment, amusement machines, and installations subject to separate industry or government regulations
 - Systems, machines, and equipment that may present a risk to life or property
 - Systems that require a high degree of reliability, such as systems that supply gas, water, or electricity, or systems that operate continuously 24 hours a day
 - Other systems that require a similar high degree of safety
- Never use the product for an application involving serious risk to life or property without first ensuring that the system is designed to secure the required level of safety with risk warnings and redundancy, and that the Yaskawa product is properly rated and installed.
- The circuit examples and other application examples described in product catalogs and manuals are for reference. Check the functionality and safety of the actual devices and equipment to be used before using the product.
- Read and understand all use prohibitions and precautions, and operate the Yaskawa product correctly to prevent accidental harm to third parties.

◆ Specifications Change

The names, specifications, appearance, and accessories of products in product catalogs and manuals may be changed at any time based on improvements and other reasons. The next editions of the revised catalogs or manuals will be published with updated code numbers. Consult with your Yaskawa representative to confirm the actual specifications before purchasing a product.

Contents

About this Manual	iii
Outline of Manual	iii
Related Manuals	iv
Using this Manual	vi
Safety Precautions	ix
Warranty	xv

1

System Configuration

1.1	Combinations of MP2000-series Products	1-2
1.2	System Configuration Examples	1-4
1.2.1	Using the MP2200	1-4
1.2.2	Using the MP2310	1-6

2

Installation and Connections

2.1	Machine Controller Installation	2-2
2.1.1	Screw Mounting	2-2
2.1.2	DIN Rail Mounting	2-2
2.1.3	Installing Optional Modules	2-5
2.1.4	Replacing and Adding Optional Modules	2-6
2.1.5	Installing and Replacing the Battery in the Basic Module	2-8
2.1.6	EXIOIF Module Connections	2-11
2.2	Connecting Devices	2-13
2.2.1	Part Names and Functions	2-13
2.2.2	Connecting the Power Supply Connector	2-21
2.2.3	MECHATROLINK Connectors	2-24
2.2.4	Connecting the RLY OUT Connector	2-25
2.2.5	Connecting the Power Supply and Other Devices	2-26

3

Machine Controller Setup

3.1	The Flow of the Setup	3-2
3.2	MPE720 Installation	3-3
3.3	Creating a Project File	3-13
3.3.1	Project Files	3-13
3.3.2	Creating a Project File	3-14
3.3.3	Setting a Project Password	3-17
3.4	Self Configuration	3-18

3.5	Placing the MPE720 Online	3-20
3.5.1	Preparing the Ethernet Connection	3-20
3.5.2	Project Link Connection	3-25
3.6	Device-specific Settings	3-29
3.6.1	Data That Is Automatically Updated during Self Configuration	3-29
3.6.2	Detailed Module Settings	3-31
3.6.3	Parameters Updated during Self Configuration	3-40
3.6.4	Setting Machine-specific Motion Parameters	3-42
3.6.5	Calendar Feature	3-51
3.6.6	Setting the Scan Times	3-52
3.7	Test Run	3-54
3.7.1	Test Run	3-54
3.7.2	Starting the Test Run and Selecting the Axis	3-55
3.7.3	Test Run Dialog Box Details	3-57

4

Creating User Programs

4.1	User Program Types and Execution Timing	4-3
4.1.1	Ladder Programs	4-3
4.1.2	Motion Programs	4-9
4.1.3	Sequence Programs	4-21
4.1.4	The M-EXECUTOR	4-23
4.1.5	Registers	4-38
4.2	Creating Ladder Programs	4-48
4.3	Creating Motion Programs	4-52
4.3.1	Creating a Group Definition	4-52
4.3.2	Creating a Motion Main Program	4-53
4.3.3	Creating a Motion Subprogram	4-55
4.4	Creating a Sequence Program	4-57
4.4.1	Creating a Sequence Main Program	4-57
4.4.2	Creating a Sequence Subprogram	4-58
4.5	Transferring Data with the MPE720	4-60
4.5.1	Writing Parameters to the Machine Controller	4-61
4.5.2	Writing into a Project File	4-62
4.5.3	Reading from the Machine Controller	4-63
4.5.4	Reading from a Project File	4-64
4.5.5	Saving to Flash Memory	4-65
4.5.6	Using a CF Card (MP2200 Only)	4-66
4.5.7	Comparing to the Machine Controller	4-68
4.5.8	Comparing Flash Memory and RAM Data	4-68
4.5.9	Comparing to a Project File	4-68
4.5.10	Comparing to a CF Card	4-68
4.6	Data Transfer without Using the MPE720	4-69
4.6.1	Using a CF Card (MP2200 Only)	4-69
4.6.2	Using the MPLoader	4-72
4.6.3	Using the MPLoad Maker	4-74

5

Debugging Programs

5.1	Debugging Ladder Programs	5-3
5.1.1	Ladder Program Runtime Monitoring	5-3
5.1.2	Register List Panes	5-4
5.1.3	Watch Panes	5-7
5.1.4	Searching and Replacing in Programs	5-8
5.1.5	Searching and Replacing in Project Files	5-10
5.1.6	Cross Reference Panes	5-14
5.1.7	Checking for Multiple Coils	5-17
5.1.8	Forcing Coils ON and OFF	5-17
5.1.9	Viewing a Called Program	5-20
5.1.10	Enabling and Disabling a Program	5-20
5.2	Debugging a Motion or a Sequence Program	5-21
5.2.1	Tab Page Items	5-22
5.2.2	Monitoring Program Execution	5-23
5.2.3	Register List Panes	5-24
5.2.4	Watch Panes	5-24
5.2.5	Searching and Replacing in Programs	5-24
5.2.6	Searching and Replacing in Project Files	5-24
5.2.7	Viewing a Motion Subprogram	5-25
5.2.8	Cross Reference Searches	5-25
5.2.9	Alarm Monitor	5-25
5.2.10	Alarm Code Details	5-27
5.3	Monitoring Machine Operation	5-30
5.3.1	Axis Monitor	5-30
5.3.2	Alarm Monitor	5-34
5.3.3	Introduction to Tracing	5-38
5.4	Tuning	5-63
5.4.1	Using SigmaWin+ (When Using a Servo)	5-63
5.4.2	Using DriveWizard Plus (When Using an Inverter)	5-63

6

Security

6.1	Project File Security	6-2
6.1.1	Setting a Project Password	6-2
6.1.2	Creating or Changing a Password	6-2
6.1.3	Deleting a Password	6-3
6.1.4	Setting the Default User	6-4
6.1.5	User Management	6-4
6.2	Program Security	6-7
6.2.1	Setting the Password	6-7
6.2.2	Changing a Password	6-8
6.2.3	Deleting a Password	6-8
6.2.4	Opening a Password-Protected Ladder Program	6-9

6.3	Online Security	6-10
6.3.1	Setting Online Security	6-11
6.3.2	Changing Online Security	6-12
6.3.3	Deleting Online Security	6-13
6.3.4	Changing the Security Key	6-14
6.3.5	Unlocking Online Security Temporarily	6-15

Appendix A

Controller Installation and Operating Conditions

A.1	General Specifications	A-2
A.1.1	Environmental Conditions	A-2
A.1.2	Mechanical Operating Conditions	A-2
A.1.3	Electrical Operating Conditions	A-2
A.2	EMC Installation Conditions	A-3

Appendix B

Motion Parameters

B.1	Fixed Parameters	B-2
B.2	Setting Parameters	B-5
B.3	Monitor Parameters	B-13

Index

Revision History

System Configuration



This chapter describes the combinations of Units and Modules in MP2000-series Machine Controllers and provides system configuration examples.

1.1	Combinations of MP2000-series Products . . .	1-2
1.2	System Configuration Examples	1-4
1.2.1	Using the MP2200	1-4
1.2.2	Using the MP2310	1-6

1.1 Combinations of MP2000-series Products

The following table shows the combinations of Units and Modules in MP2000-series Machine Controllers.

Product Name	Abbreviation	Description	MP2200	MP2300, MP2310, MP2300S
CPU	CPU-01	CPU	●	×
	CPU-02	CPU+USB+CFIF	●	×
	CPU-03	CPU+Ethernet+CFIF	●	×
	CPU-04	CPU+Ethernet	●	×
	MPU-01	CPU+SVC-01	● Ver. 2.73 or higher	● Ver. 2.73 or higher (MP2300 is not supported)
Expansion	EXIOIF	Expansion	●	×
Optional Modules Communications	217IF-01	Serial (RS-232C + RS-422/ RS485)	●	●
	218IF-01	Ethernet + RS-232C	●	●
	218IF-02	Ethernet + RS-232C	● Ver. 2.60 or higher	● Ver. 2.60 or higher
	260IF-01	DeviceNet + RS-232C	●	●
	261IF-01	PROFIBUS + RS-232C	●	●
	262IF-01	FL-net	● Ver. 2.63 or higher	● Ver. 2.63 or higher
	263IF-01	EtherNet/IP	● Ver. 2.64 or higher	● Ver. 2.64 or higher
	264IF-01	EtherCAT	● Ver. 2.73 or higher	● Ver. 2.73 or higher
	265IF-01	CompoNet	● Ver. 2.74 or higher	● Ver. 2.74 or higher
	266IF-01	PROFINET Master	● Ver. 2.81 or higher	● Ver. 2.81 or higher
	266IF-02	PROFINET Slave	● Ver. 2.82 or higher	● Ver. 2.82 or higher
	267IF-01	CC-Link Master	● Ver. 2.86 or higher	● Ver. 2.86 or higher
	269IF-01	CC-Link IE Field Slave	● Ver. 3.03 or higher	● Ver. 3.03 or higher
	215AIF-01	CP-215	●	●
		MPLINK	● Ver. 2.41 or higher	● Ver. 2.41 or higher
	AFMP-01	AnyWire-DB master* ¹	● Ver. 2.02 or higher	● Ver. 2.02 or higher
	AFMP-02-C	CC-Link interface board* ¹	● Ver. 2.51 or higher	● Ver. 2.51 or higher
	AFMP-02-CA	AnyWire-DB interface board with CC-Link* ¹	● Ver. 2.51 or higher	● Ver. 2.51 or higher
	MPALN00-0	A-net/A-Link master unit* ²	● Ver. 2.46 or higher	● Ver. 2.46 or higher
	MPCUNET-0	CUnet Master Unit* ²	● Ver. 2.81 or higher	● Ver. 2.81 or higher
MPHLS-01	HSL Master module* ³	● Ver. 2.84 or higher	● Ver. 2.84 or higher	

Continued on next page.

Continued from previous page.

Product Name	Abbreviation	Description	MP2200	MP2300, MP2310, MP2300S
Motion	SVB-01	MECHATROLINK-II	● Ver. 2.02 or higher	● Ver. 2.02 or higher
	SVC-01	MECHATROLINK-III	● Ver. 2.70 or higher	● Ver. 2.70 or higher
	SVA-01	Analog outputs	● Ver. 2.20 or higher	● Ver. 2.20 or higher
	PO-01	Pulse outputs	● Ver. 2.44 or higher	● Ver. 2.44 or higher
Optional Modules I/O	LIO-01	16 inputs, 16 sinking outputs, and 1 pulse input channel	●	●
	LIO-02	16 inputs, 16 sourcing out- puts, and 1 channel pulse input	●	●
	LIO-04	32 inputs and 32 sinking out- puts	● Ver. 2.20 or higher	● Ver. 2.20 or higher
	LIO-05	32 inputs and 32 sourcing outputs	● Ver. 2.32 or higher	● Ver. 2.32 or higher
	LIO-06	8 digital inputs, 8 digital sinking outputs, 1 ana- log input channel, 1 ana- log output channel, and 1 pulse counter channel	● Ver. 2.63 or higher	● Ver. 2.63 or higher
	DI-01	64 inputs (sinking/sourcing)	● Ver. 3.07 or higher	● Ver. 3.07 or higher
	DO-01	64 sinking outputs	● Ver. 2.32 or higher	● Ver. 2.32 or higher
	AI-01	Analog input	● Ver. 2.40 or higher	● Ver. 2.40 or higher
	AO-01	Analog output	● Ver. 2.44 or higher	● Ver. 2.44 or higher
	CNTR-01	Counter	● Ver. 2.44 or higher	● Ver. 2.44 or higher

*1. AnyWire Co., Ltd.

*2. Algo System Co., Ltd.

*3. M-System Co., Ltd.

1.2 System Configuration Examples

Configuration examples are provided below for the MP2000 Series.

1.2.1 Using the MP2200

One-Rack Configuration

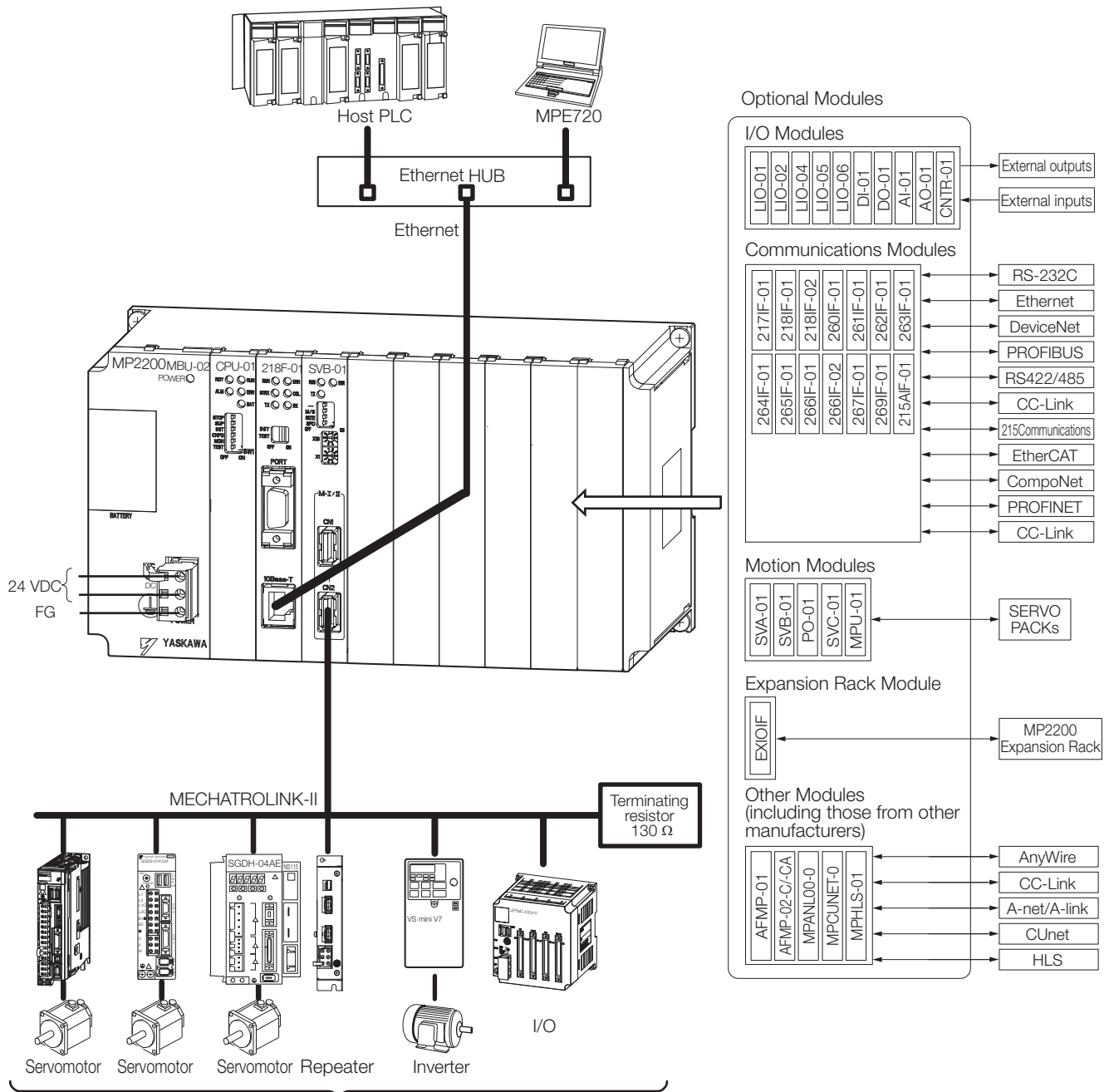

Max. 21 stations including I/O.
(Max. 16 stations servo can be included.)

- Note: 1. Use the connecting cables and connectors recommended by Yaskawa. Always check the device to be used and select the correct cable for the device.
2. 24-VDC power supply is not provided by Yaskawa.

Four-Rack Configuration

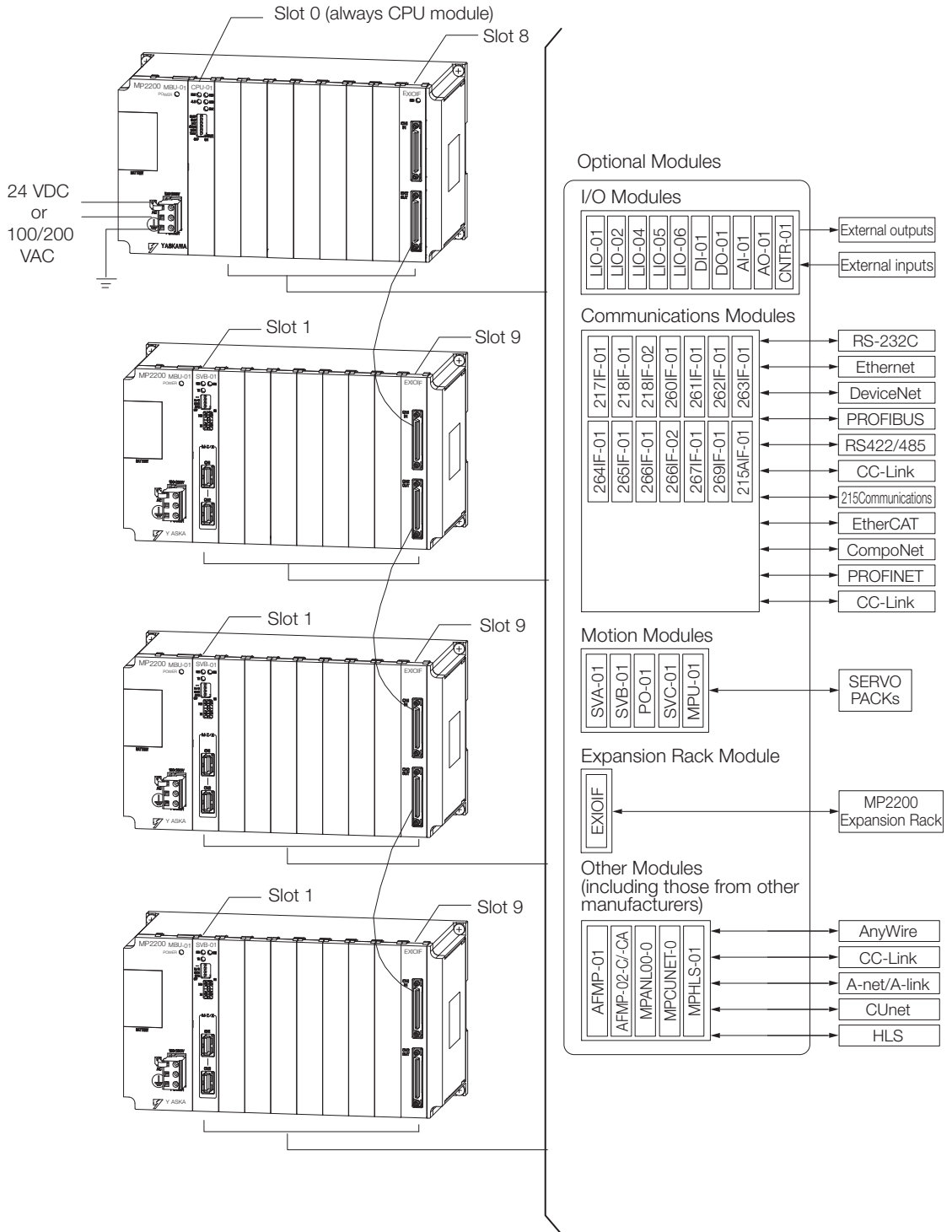

* Use an EXIOIF cable that has a maximum length of 6.0 m.

1.2.2 Using the MP2310

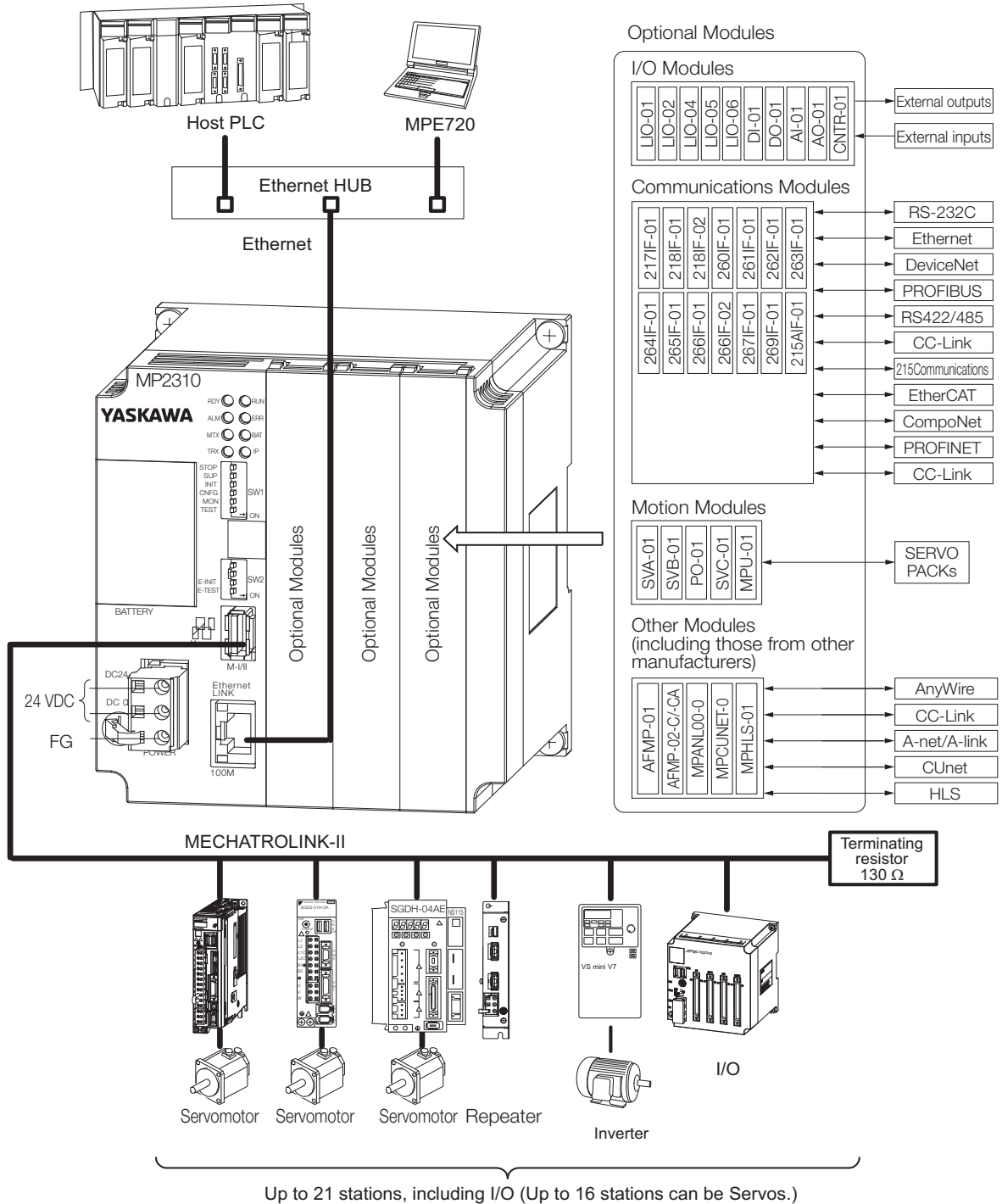

Installation and Connections

2

This chapter describes the installation and connections of Machine Controllers.

2.1 Machine Controller Installation 2-2

- 2.1.1 Screw Mounting 2-2
- 2.1.2 DIN Rail Mounting 2-2
- 2.1.3 Installing Optional Modules 2-5
- 2.1.4 Replacing and Adding Optional Modules 2-6
- 2.1.5 Installing and Replacing the Battery
in the Basic Module 2-8
- 2.1.6 EXIOIF Module Connections 2-11

2.2 Connecting Devices 2-13

- 2.2.1 Part Names and Functions 2-13
- 2.2.2 Connecting the Power Supply Connector 2-21
- 2.2.3 MECHATROLINK Connectors 2-24
- 2.2.4 Connecting the RLY OUT Connector 2-25
- 2.2.5 Connecting the Power Supply and
Other Devices 2-26

2.1 Machine Controller Installation

You can use either of the following methods to install a Machine Controller.

- Screw mounting
- DIN rail mounting

Refer to the following appendix for more information on the installation and application requirements.

 A.1 General Specifications on page A-2

2.1.1 Screw Mounting

Press the Machine Controller against the mounting surface, and use the four mounting screws to firmly secure it.

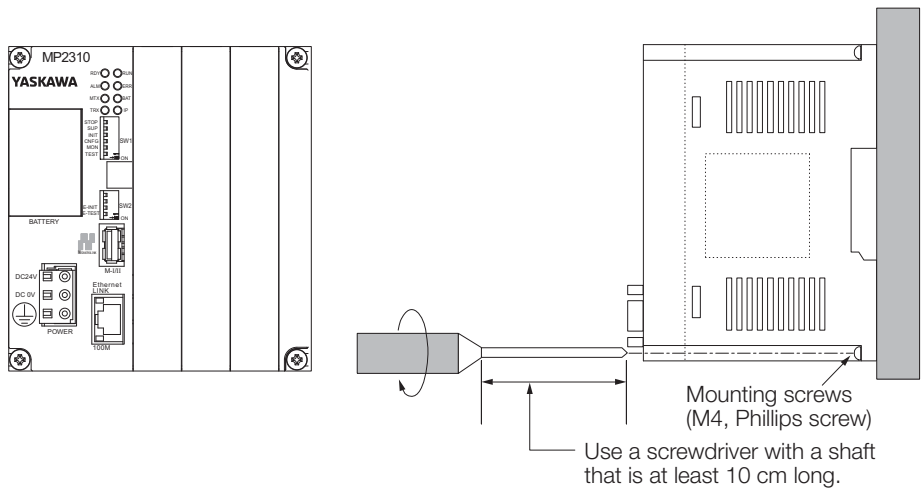

Note: Install the Controller perpendicularly to the wall, as shown in the above figure.

2.1.2 DIN Rail Mounting

This section describes how to install the Controller by mounting it on DIN rail.

DIN Rail Types and the Spacer

Various types of DIN rails are available with a 7-mm to 15-mm gap from the mounting surface as shown on the left in the following figure. If you mount a Machine Controller using a DIN rail with a 10-mm or larger gap, install a spacer on the back of and near the bottom of the Machine Controller, as shown on the right side of the following figure, to protect it from vibration and shock.

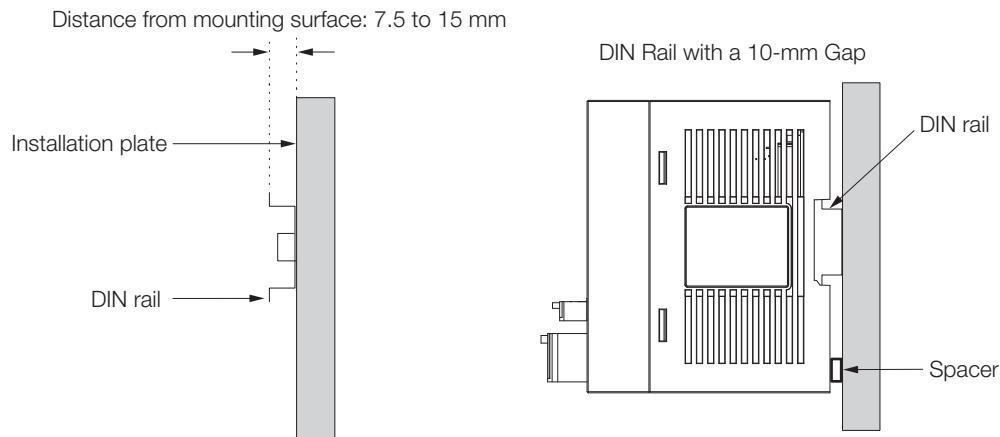

Procedure for Mounting to a DIN Rail

1. Attach the DIN rail to the control panel and secure it in place.

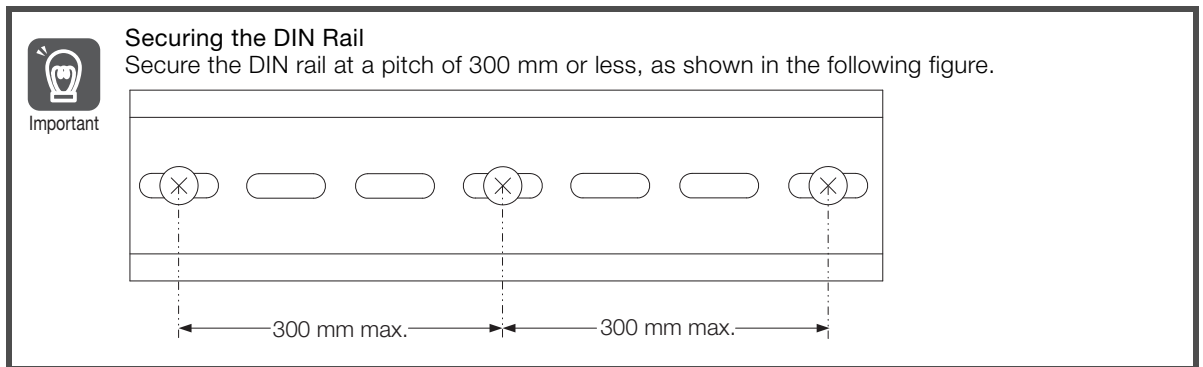

2. Insert the DIN Rail Mounting Clips in the two slots on the back of the Machine Controller, and press them in until they reach the dotted line shown in the following figure.

Back of the MP2310

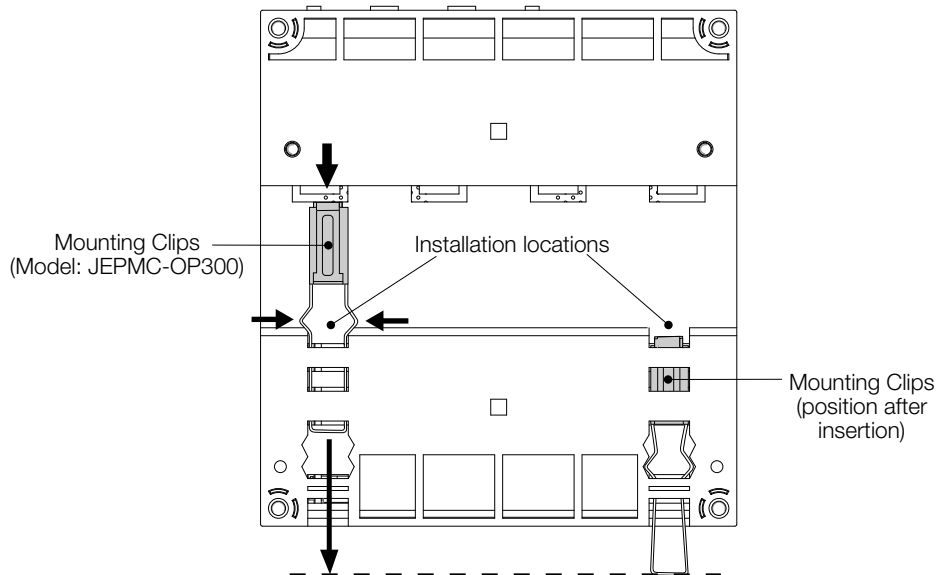

Note: The Mounting Clips have a front and a back surface. Insert each Clip so that its front surface faces outward.

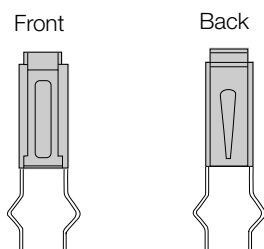

3. Pull the DIN Rail Mounting Clips down to release them.

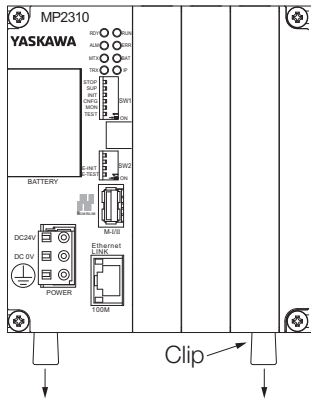

4. Hook the Machine Controller to the top of the DIN rail (a in the figure), and then press the Controller toward the mounting surface (b in the figure) to secure it in place.

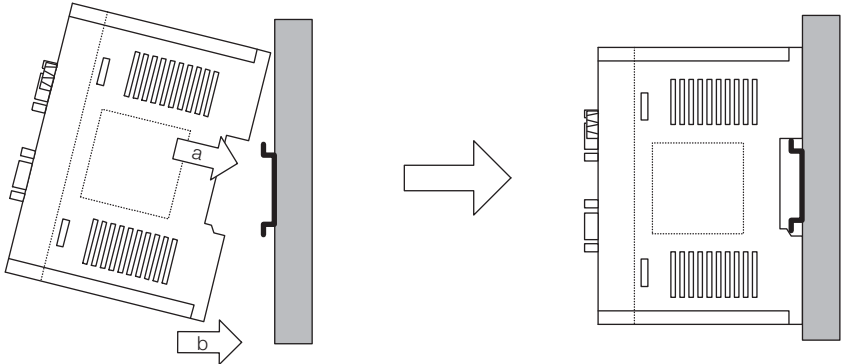

5. Press in the DIN Rail Mounting Clips to lock them in place.

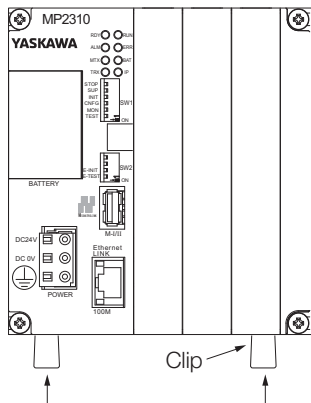

6. Place end plates on both sides of the Machine Controller to secure it to the DIN rail.

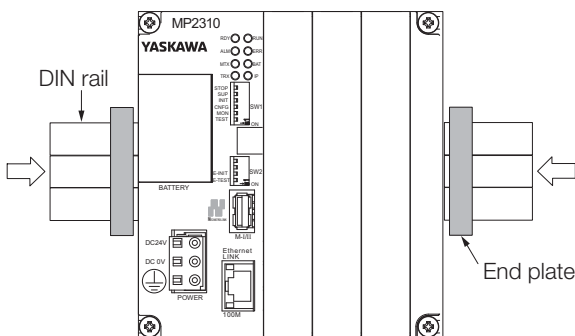

This completes the installation procedure.

Information Refer to the manual for the MP2100 or MP2500 for more information on installation.

Procedures for Removing from the DIN Rail

You can remove the Controller by reversing the order of the mounting procedure.

2.1.3 Installing Optional Modules

Use the following procedure to install Optional Modules.

1. Hold the top and bottom of the Optional Module to be installed, line up the Module with the left side of the guide rail inside the option slot, and then insert the Module straight in.



The FG bar inside and on the bottom may be damaged if the Module is not inserted along the guide rail.

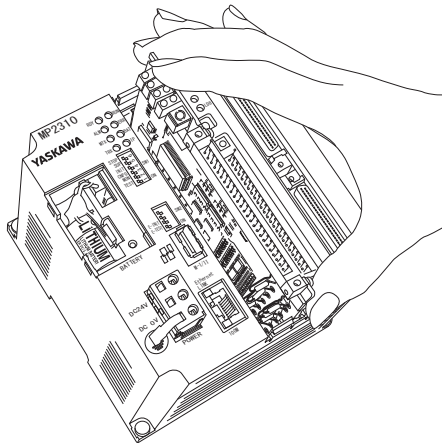

2. After the Optional Module is completely inserted, place your hand on the front of the Optional Module and press the Optional Module firmly until it mates with the Mounting Base connectors in the Unit. The front of the Optional Module and the tabs will be aligned if the Optional Module has been installed properly.
3. Place the hole on the bottom of the panel of the Optional Module onto the tab on the bottom of the Unit. Next, hook the hole at the top of the panel of the Optional Module onto the tab on the Unit.

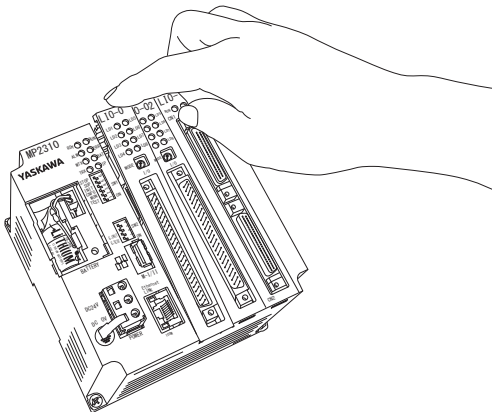

This completes the installation procedure.



Always use Option Covers (model: JEPMC-OP2300) to cover unused slots.

2.1.4 Replacing and Adding Optional Modules

Use the following procedure to replace or add Optional Modules.



Always create a backup before replacing or adding Optional Modules.
Back up the program from the Machine Controller to the PC using the MPE720.

1. Turn OFF the power supply and disconnect all cables from the Machine Controller.
2. Pull the notch on the side toward you to remove the battery cover.

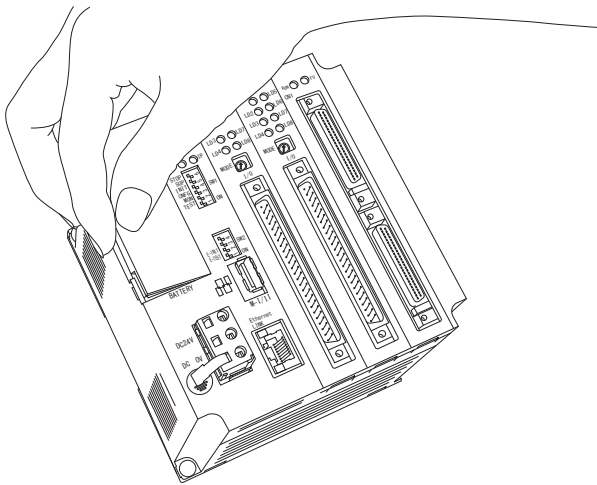

3. Insert the protruding part of the battery cover into the slot on top of the Optional Module panel to unhook the tab. Face the front of the battery cover toward you for this operation.

Information Use the same method to remove the Option Cover from an unused slot before adding an Optional Module.

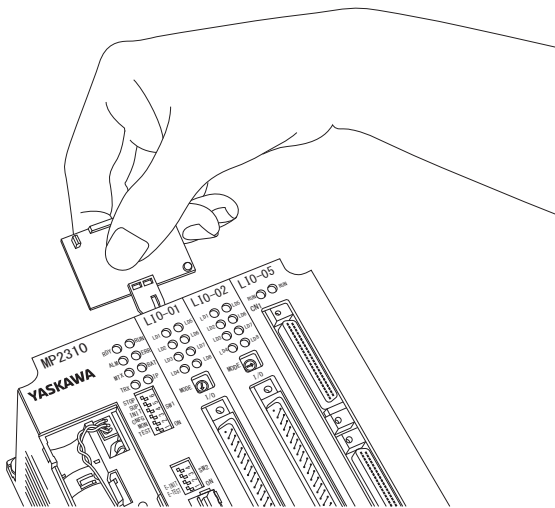

Unhook the bottom tab in the same way.

4. Pull the top of the Optional Module panel toward you and remove it. A notch on the Optional Module will be visible from the gap with the panel. Hook the round knob on the battery cover into the notch in the Optional Module.

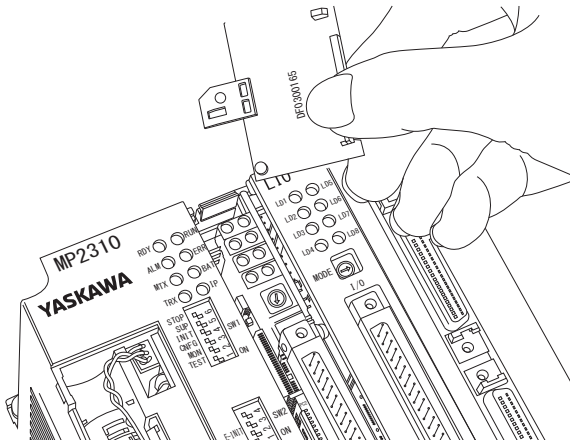

5. Hold the center of the battery cover, and turn it around the round knob while pushing it toward the back to disconnect the Module from the Mounting Base connectors. Then, pull the Module forward.

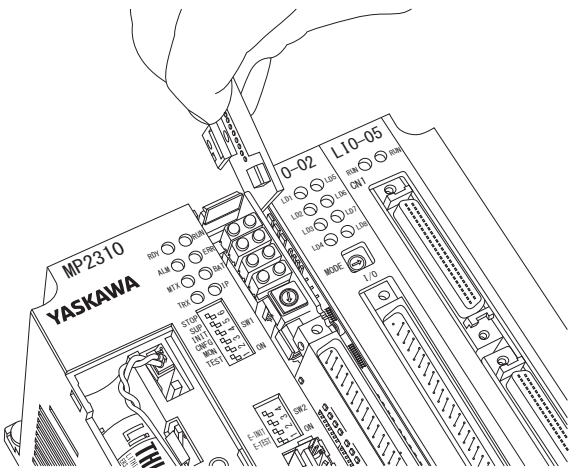

6. Hold the Optional Module at the top and bottom and pull it straight out. Hold the edges of the Module and avoid touching the components on the Module.

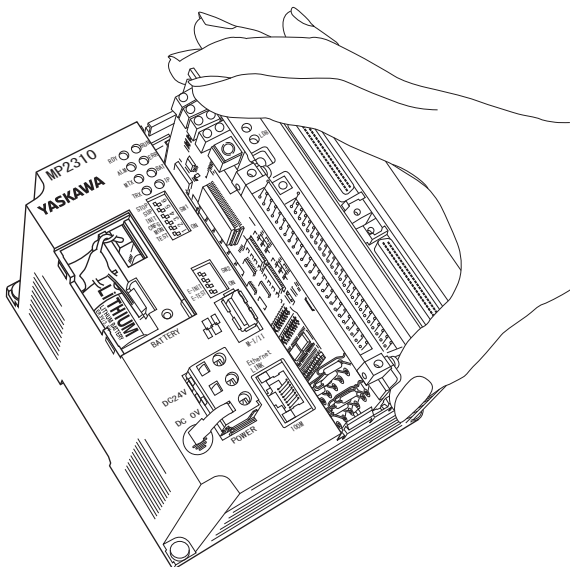

Note: Put the Module that you removed into the bag that was supplied when you purchased it and store the Module in this bag.

2.1.5 Installing and Replacing the Battery in the Basic Module

The Battery in the Basic Module backs up the data that is saved by the Basic Module in the event of a power failure or when the power to the Basic Module is turned OFF. The Battery provides backup power for the following data.

- M registers
- S registers
- Trace memory
- Alarm history
- Table data



Important

- The Basic Module comes with one Battery. The Battery is not connected when the Module is delivered.
- The Battery can provide backup power for the memory for a total power OFF time of 1 year. However, this depends on the actual operating conditions, such as the ambient temperature.
- When the total power OFF times reaches 1 year, the voltage of the Battery will drop, and the BAT indicator on the Basic Module will light. When this occurs, always replace the Battery with a new one within two weeks. Delayed replacement of the Battery will result in loss of the data stored in the memory of the Basic Module.
- The Battery is warranted for 5 years.

Battery Appearance

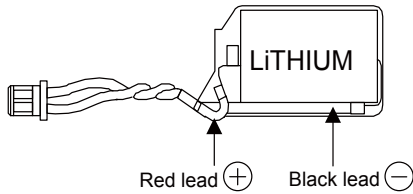

JZSP-BA01 Battery Specifications

Type	Lithium primary cell
Battery Model	ER3VC
Manufacturer	Toshiba Home Appliance Corp.
Nominal Voltage	3.6 V
Nominal Capacity	1000 mAh
Lithium Content	0.3 g
Number of Batteries Used	1

Note: This Battery is not available on the retail market. Order the Battery from Yaskawa Controls Co., Ltd. (The model number is JZSP-BA01.)

Battery Installation



Important

The Basic Module comes with one Battery. The Battery is not connected when the Module is delivered.



CAUTION

- Suitable battery installation must be performed and it must be performed only by an experienced technician.
There is a risk of electrical shock, injury, or device damage.
- Do not touch the electrodes when installing the Battery.
Static electricity may damage the electrodes.

1. Confirm that the power supply to the Basic Module is turned OFF.
2. Open the battery cover on the front of the Module.

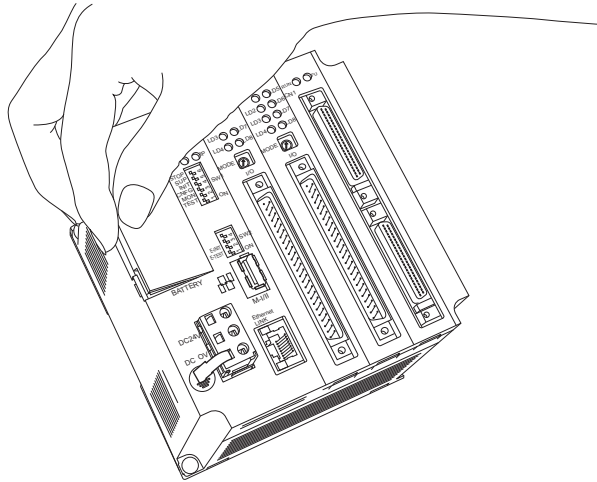

3. Securely connect the lead connector of the Battery to the connector in the Basic Module, and insert the Battery into the battery holder.

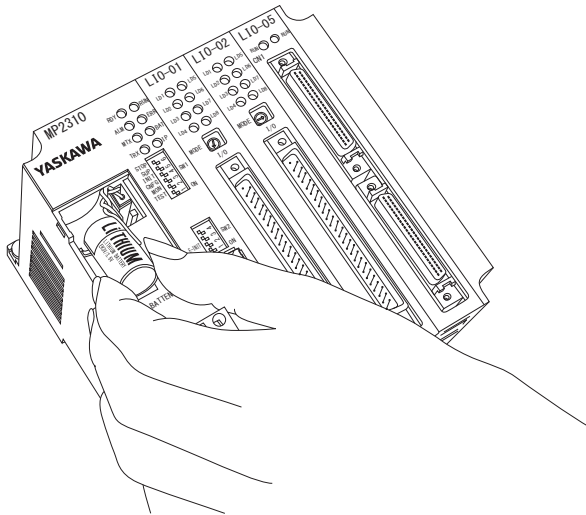

4. Close the battery cover and turn ON the Basic Module.
5. Installation of the Battery is complete when the RDY indicator on the Basic Module goes out.

Battery Replacement



CAUTION

- Suitable battery replacement must be performed and it must be performed only by an experienced technician.
There is a risk of electrical shock, injury, or device damage.
- Replace the Battery only while power is supplied to the Basic Module.
Replacing the Battery while the power supply to the Basic Module is turned OFF may result in loss of the data stored in memory in the Module.
- Do not touch the electrodes when replacing the Battery.
Static electricity may damage the electrodes.
- Observe all local laws and ordinances when you dispose of used Batteries.

1. Back up the programs and data stored in the Basic Module.

Note: The backup can be used to recover the data if the data accidentally gets deleted during Battery replacement. Refer to the following manual for details on backing up the data.

 [4.5 Transferring Data with the MPE720 - 4.5.3 Reading from the Machine Controller on page 4-63](#)

2. Confirm that the RDY indicator on the Basic Module is lit.

3. Open the battery cover on the front of the Unit.

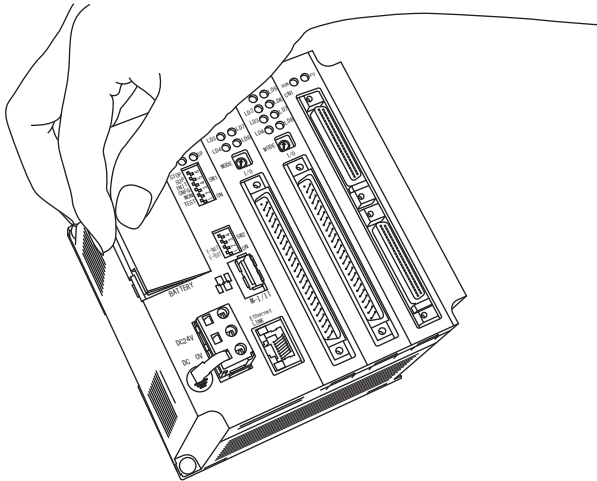

4. Disconnect the lead connector of the Battery from the connector on the Basic Module, and remove the Battery from the battery holder.

5. Securely connect the lead connector of the Replacement Battery to the connector on the Basic Module, and insert the Replacement Battery into the battery holder.

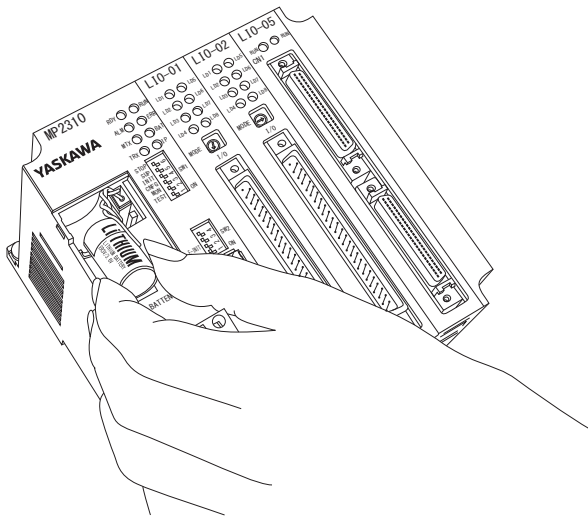

6. Confirm that the BAT indicator of the Basic Module is not lit.

7. Close the cover. This concludes the Battery replacement procedure.

2.1.6 EXIOIF Module Connections

An EXIOIF Module is mounted to an MP2200 Base Unit (MBU-01, MBU-02, or MBU-03). You can use the Module to add up to four Expansion Racks.

Connectors

The connectors on the EXIOIF Module are shown in the following figure.

These connectors are used to add MP2200 Base Units (MBU-01, MBU-02, or MBU-03).

Use the standard cables. Refer to the following section for information on the standard cables.

 *Standard Cables (page 2-12)*

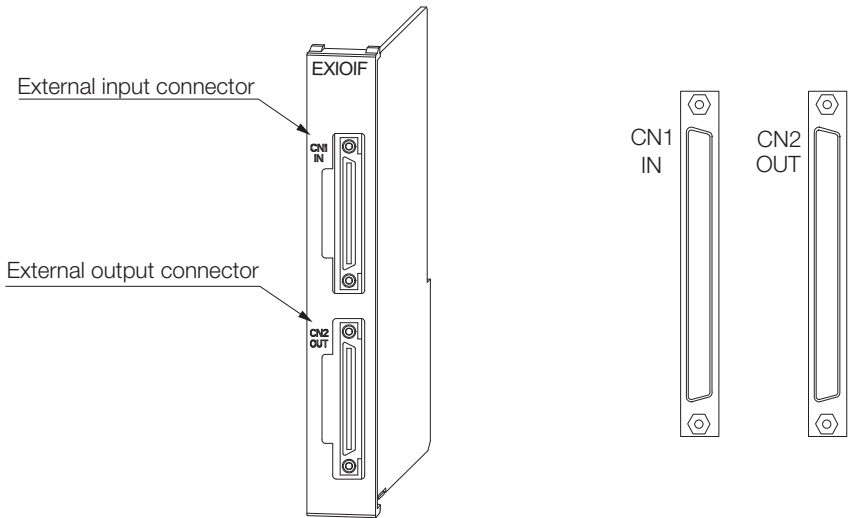

The connection method for the external I/O connectors is shown in the following figure.

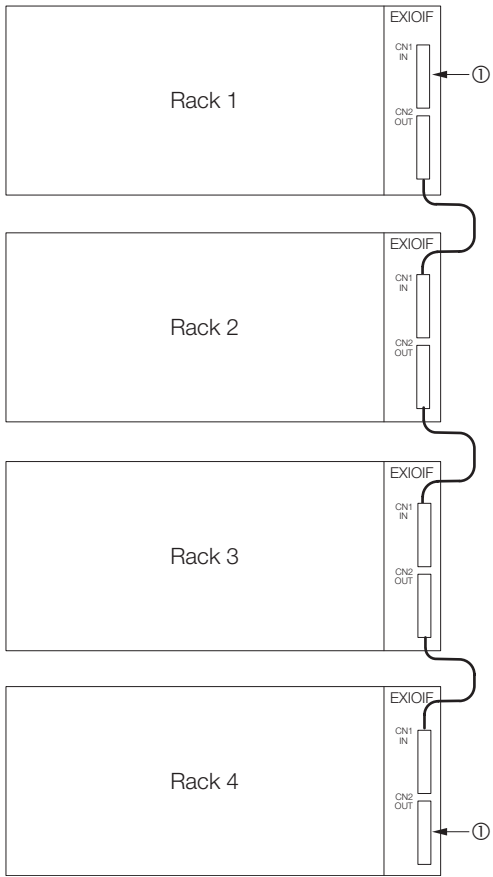

Note: Attach the enclosed dust caps to the unused connectors (Ⓛ in the above figure).

Standard Cables

Name	Model	Length	Description
Cables with Connectors on Both Ends	JEPMC-W2091-A5-E	0.5 m	Shielded cables, equivalent to UL 20276, 0.08 mm ² (AWG28), two ferrite cores attached
	JEPMC-W2091-01-E	1.0 m	
	JEPMC-W2091-2A5-E	2.5 m	
	JEPMC-W2094-A5-E	0.5 m	Shielded cables, equivalent to UL 20276, 0.05 mm ² (AWG30), four ferrite cores attached
	JEPMC-W2094-01-E	1.0 m	
	JEPMC-W2094-2A5-E	2.5 m	

Note: 1. Do not exceed 6.0 m for the total cable length when you add Racks.
 2. Make all connections on a 1:1 basis.

Standard Cable Appearance

◆ JEPMC-W2091-□□□-E



◆ JEPMC-W2094-□□□-E

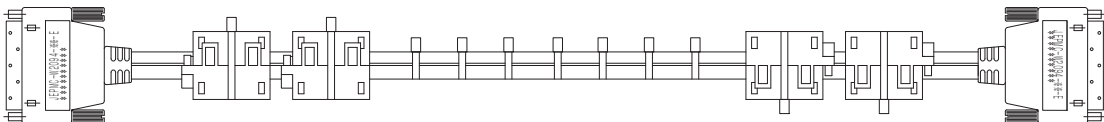

2.2 Connecting Devices

This section explains how to connect devices to the Machine Controllers.

2.2.1 Part Names and Functions

The following figure shows the names and functions of the parts of the Machine Controller and the Servo Drive.

MP2200 (When Using the MBU-01 and CPU-01)

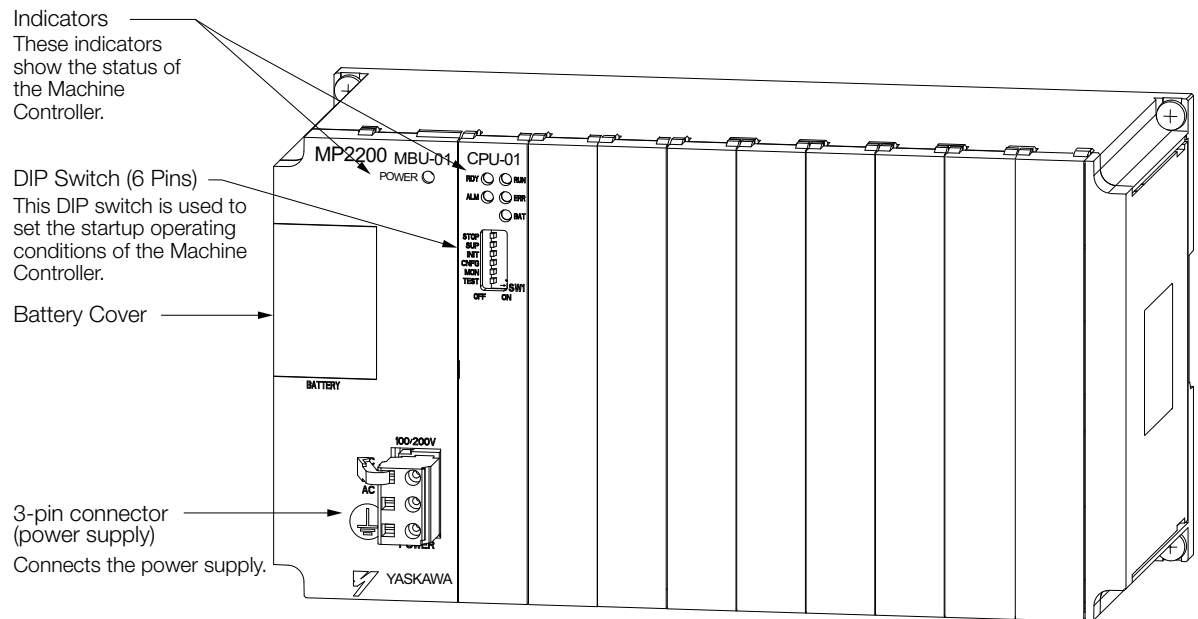

MP2310

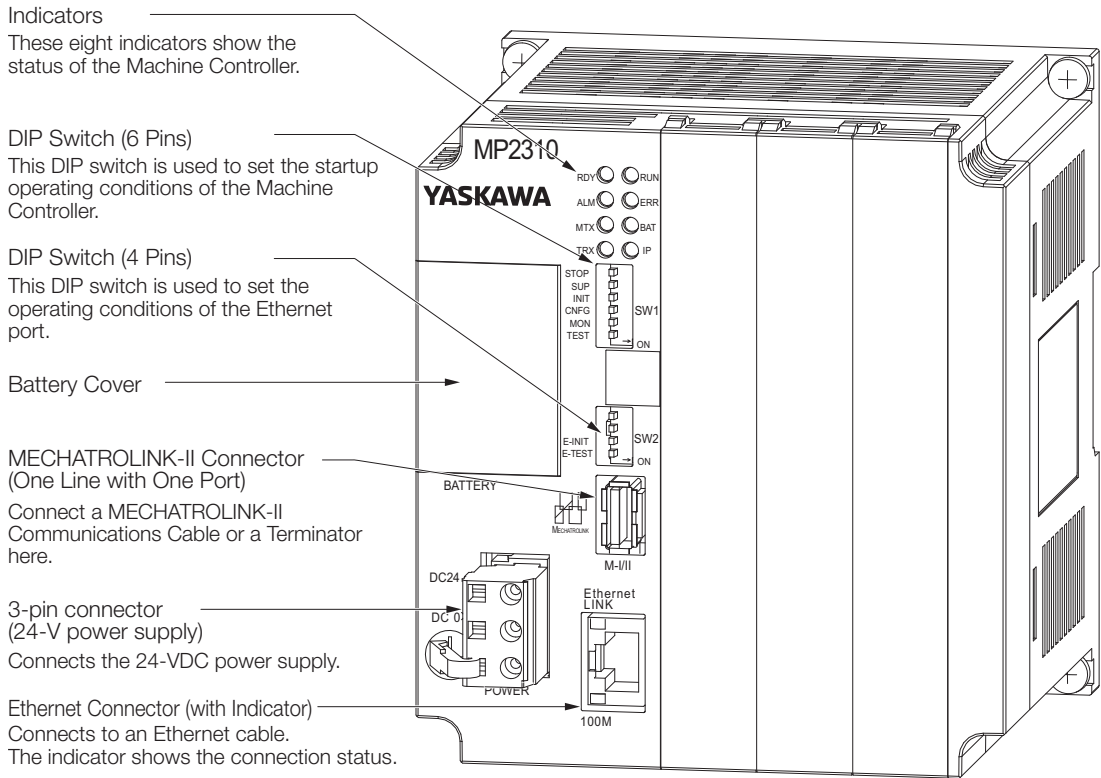

Note: Some Controllers have two MECHATROLINK-II connectors. If only one of these connectors is connected to a MECHATROLINK Communications Cable, then you must connect a Terminator to the other connector.

MP2300S

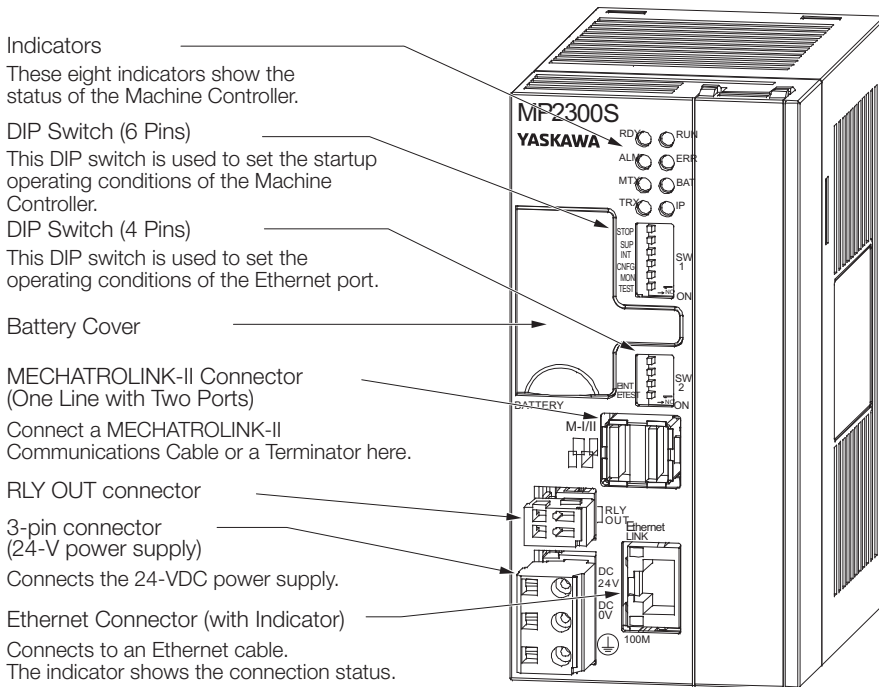

MP2400

- Indicators
 These eight indicators show the status of the Machine Controller.

- DIP Switch (6 Pins)
 This DIP switch is used to set the startup operating conditions of the Machine Controller.

- DIP Switch (4 Pins)
 This DIP switch is used to set the operating conditions of the Ethernet port.

- Battery Cover

- MECHATROLINK-II Connector (One Line with One Port)
 Connect a MECHATROLINK-II Communications Cable or a Terminator here.

- RLY OUT connector

- 3-pin connector (24-V power supply)
 Connects the 24-VDC power supply.

- Ethernet Connector (with Indicator)
 Connects to an Ethernet cable.
 The indicator shows the connection status.

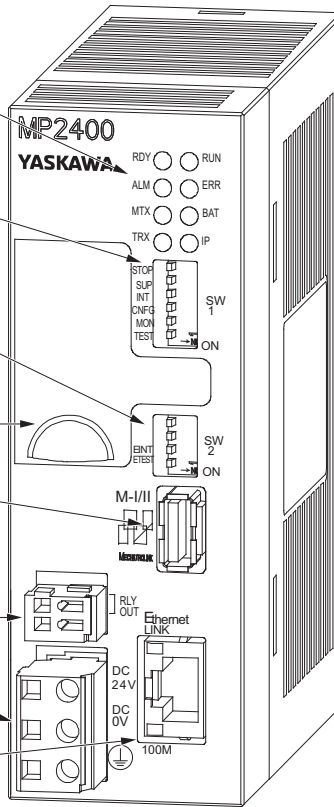

Servo Drive

◆ Σ-7-series SERVOPACK

■ Reference-type Σ-7S SERVOPACK with MECHATROLINK-II Communications (model: SGD7S-□□□□10A)

SERVOPACK with the Front Cover Open

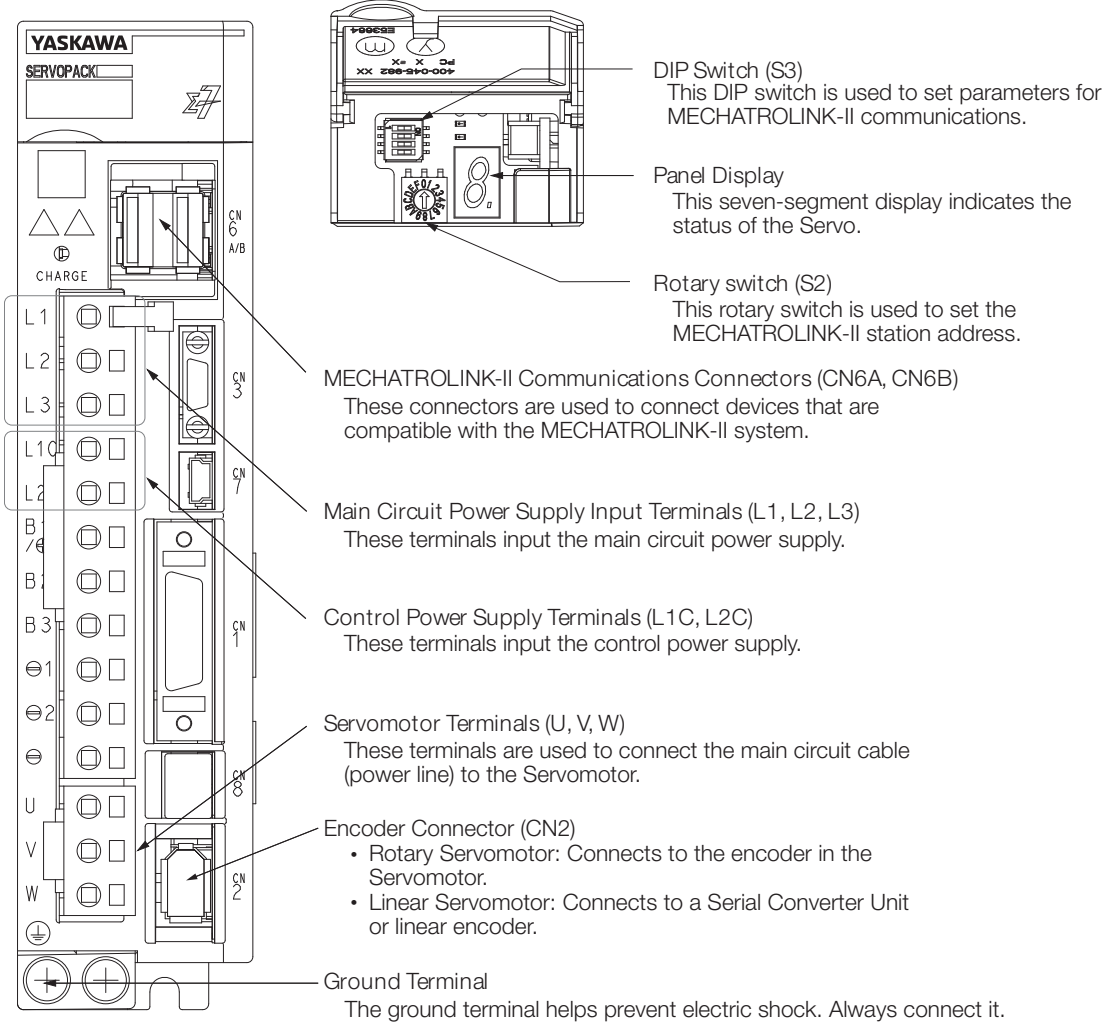

■ Reference-type Σ -7S SERVOPACK with MECHATROLINK-III Communications (model: SGD7S-□□□□20A)

SERVOPACK with the Front Cover Open

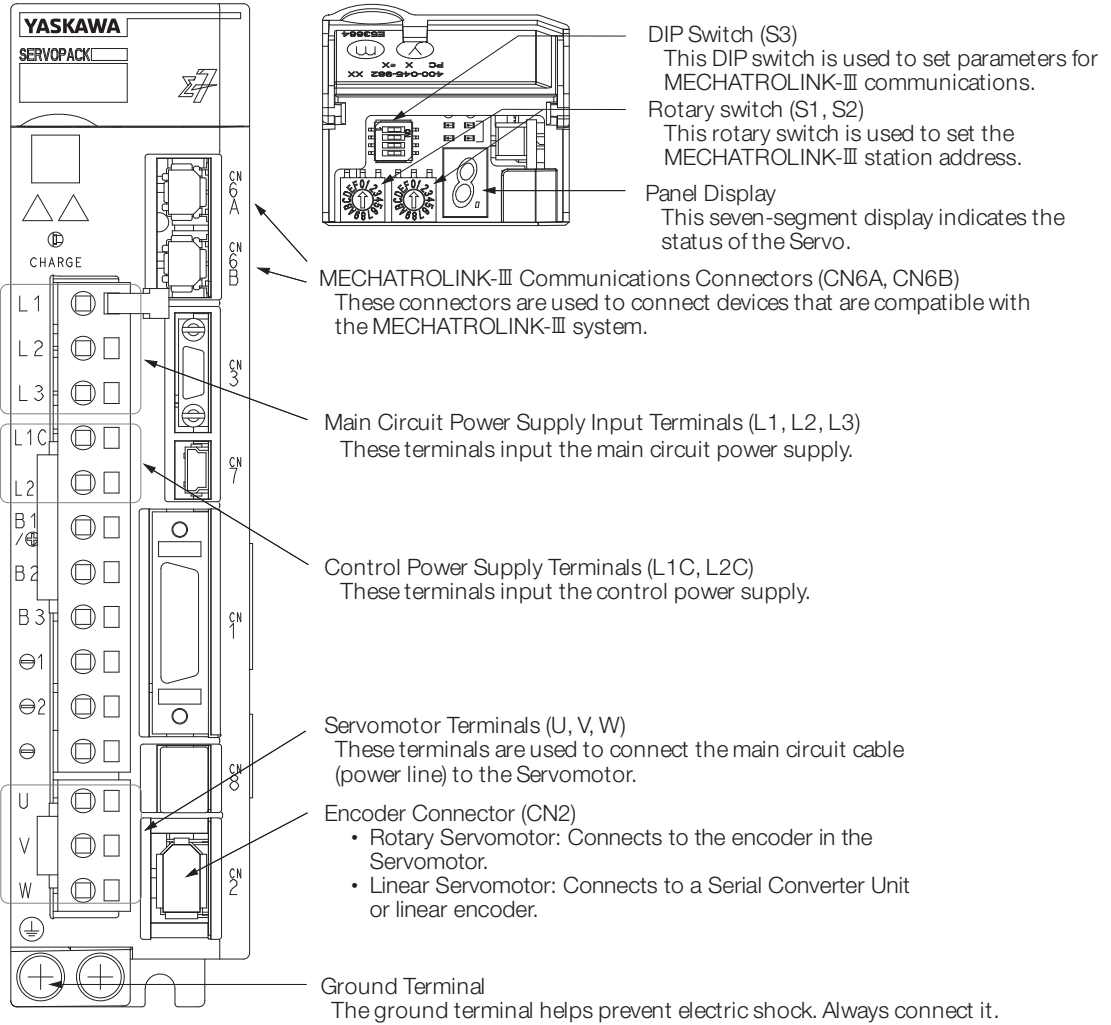

■ Σ-7W SERVOPACK (model: SGD7W-□□□□20A)

SERVOPACK with the Front Cover Open

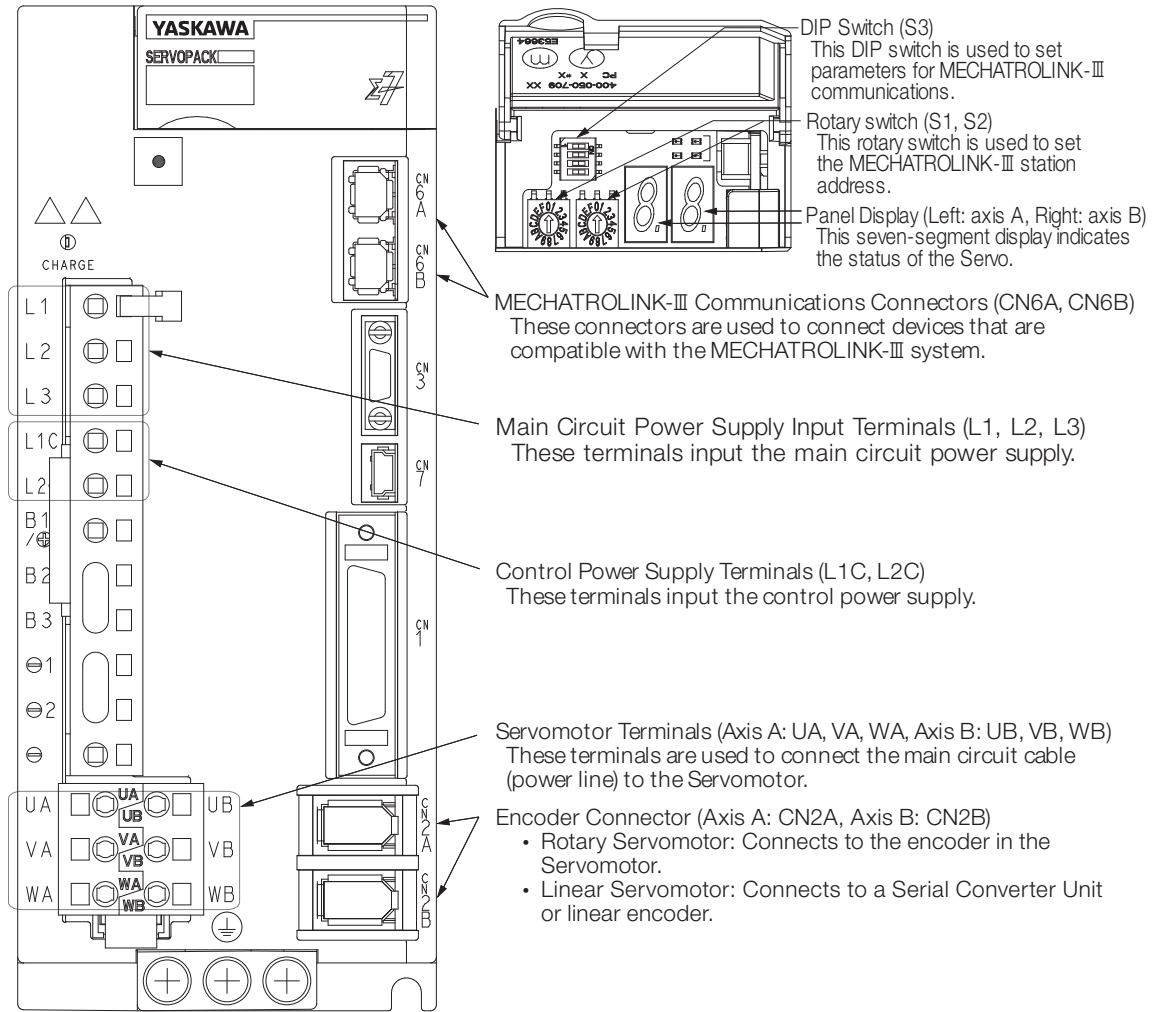

◆ Σ -V series SERVOPACK

■ Reference-type Σ -V SERVOPACK with MECHATROLINK-II Communications (model: SGD-V-□□□□1□□)

SERVOPACK with the Front Cover Open

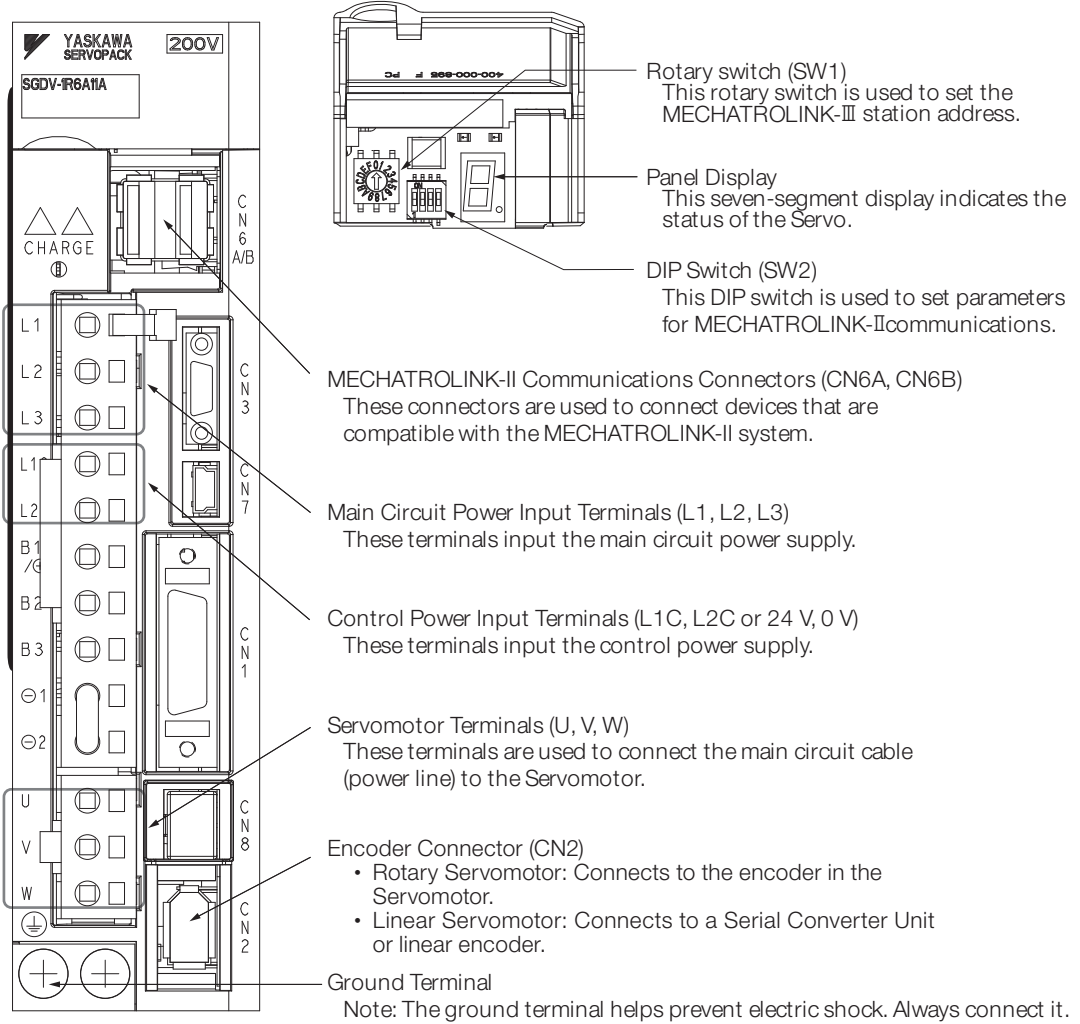

■ Reference-type Σ -V SERVOPACK with MECHATROLINK-III Communications (model: SGDV-□□□□2□□)

SERVOPACK with the Front Cover Open

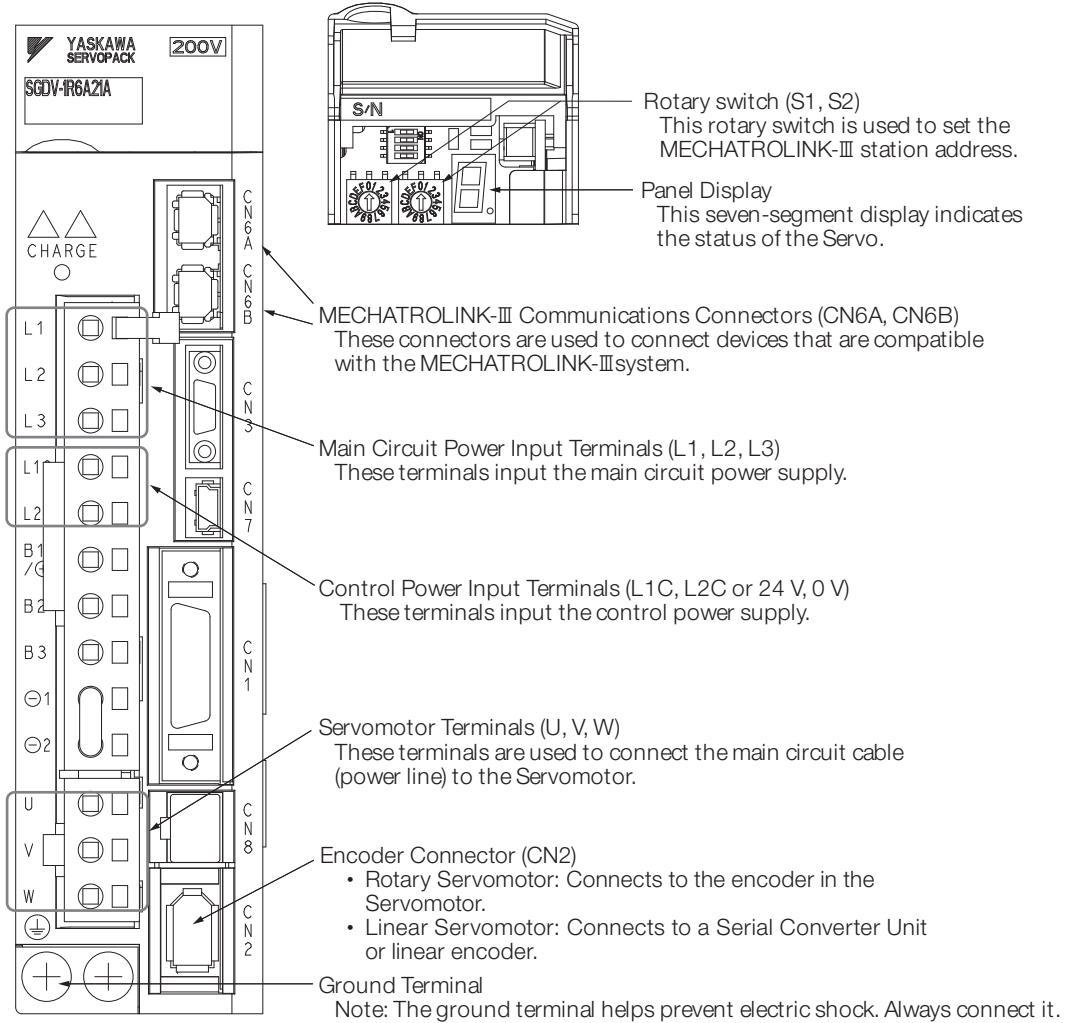

2.2.2 Connecting the Power Supply Connector

This section describes how to connect the power supply connector.

Power Connector Specifications, Pin Assignments, and Connection Method

◆ 100/200-VAC Power Supply

The power supply for the Machine Controller is 100/200 VAC. Refer to the following figure for the connection methods.

Name	Connector Label	Number of pins	Connector Models		
			Module Side	Cable Side	Manufacturer
Power Connector	POWER	3	721-863	721-203/026	WAGO Company of JAPAN

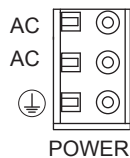

Pin No.	Signal Label	Description
3	AC	AC input
2	AC	AC input
1	FG	Connects to the frame ground. (Ground to 100 Ω max.)

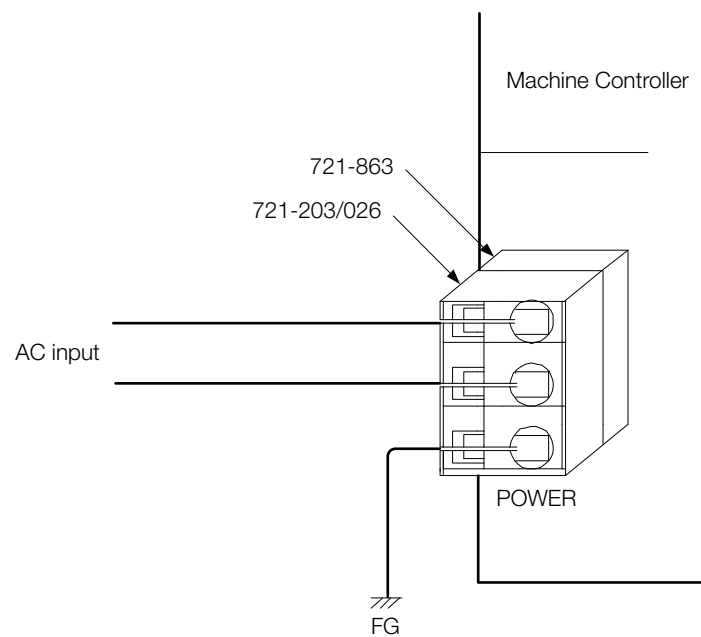

■ Procedure to Make a 100/200-VAC Power Cable

The power supply pins are contained in a removable connector. Use the following procedure to wire the power supply connector. Use a twisted-pair cable with a wire size of AWG28 to AWG13 (0.08 to 2.6 mm²) to connect the 100/200-VAC power supply to the power supply connector on the Controller.

Use the following procedure to make the cable.

1. Strip the wires.

Strip the wires for a length of 8 to 9 mm from the end to expose the conductors.

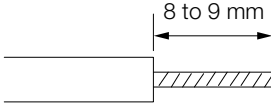

2. Clamp the wires.

Insert the conductors into the back of the plug and clamp them securely.

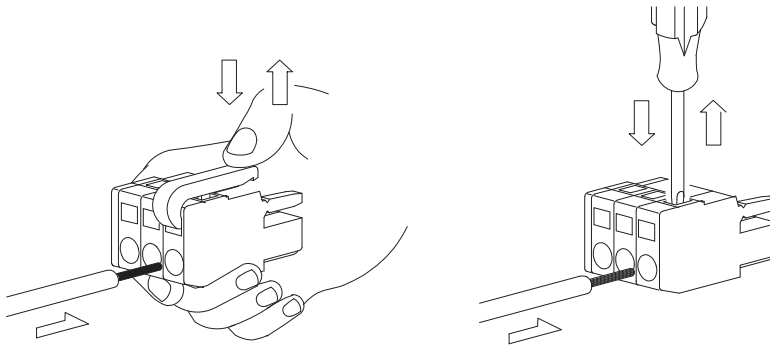

◆ Cable for a 24-VDC Power Supply

The power supply for the Machine Controller is 24 VDC. Refer to the following figure for the connection methods.

Name	Connector Label	Number of pins	Connector Models		
			Module Side	Cable Side	Manufacturer
Power Connector	POWER	3	721-863	721-203/026	WAGO Company of JAPAN

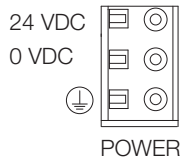

Pin No.	Signal Label	Description
3	24 VDC	Power input wire for 24 VDC
2	0 VDC	Power input wire for 0 VDC
1	FG	Connects to the frame ground. (Ground to 100 Ω max.)

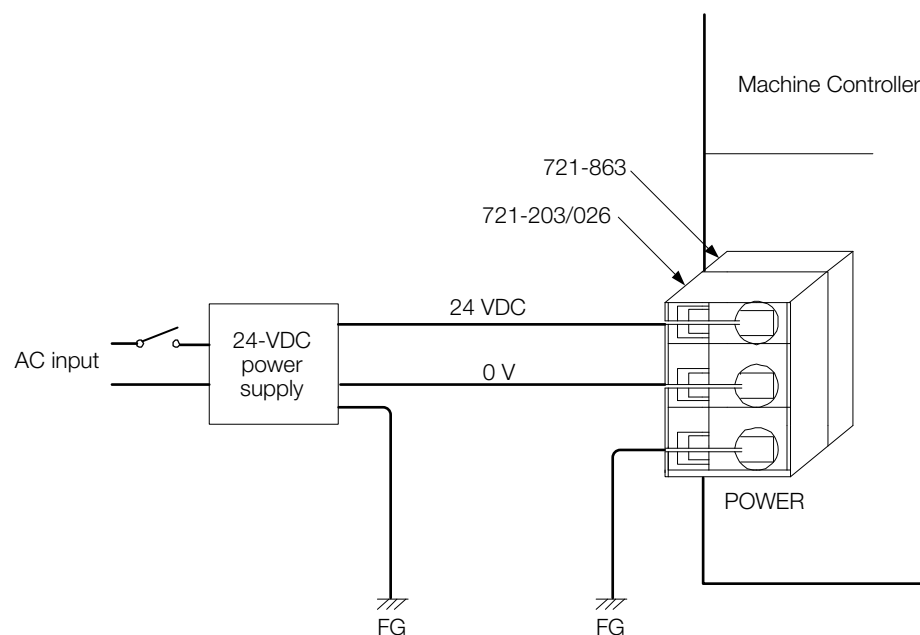

Note: Use an isolating 24-VDC power supply, and install the power supply switch on the AC side of the power supply. If the switch is installed on the 24-VDC side, the inrush current may reach approx. 40 A when the power is turned ON.

■ Procedure to Make a 24-VDC Power Cable

The power supply pins are contained in a removable connector. Use the following procedure to wire the power supply connector. Use a twisted-pair cable with a wire size of AWG18 to AWG13 (0.8 to 2.6 mm²) to connect the 24-VDC power supply to the power supply connector on the Controller.

The procedure to make the cable is the same as for the 100/200-VAC power supply cable.

 Procedure to Make a 100/200-VAC Power Cable (page 2-22)

2.2.3 MECHATROLINK Connectors

MECHATROLINK connector is used to connect the Machine Controller to the SERVOPACKs and distributed I/O via MECHATROLINK cables.

Specifications and Pin Arrangement

Name	Connector Name	No. of Pins	Connector Model		
			Module	Cable	Manufacturer
MECHATROLINK Connector	M-I/II	4	1903814-1	2040305-1	Tyco Electronics Japan G.K.



No.	Signal Name	Description
1	(NC)	Not used
2	/DATA	Signal -
3	DATA	Signal +
4	SH	Not used
Shell	Shield	Connect a shielded wire.

Cables

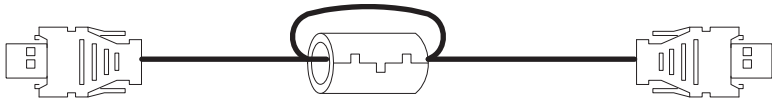
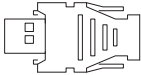
Name and Specification	Model Number	Length
MECHATROLINK Cable MECHATROLINK Connector – MECHATROLINK Connector 	JEPMC-W6002-A5-E	0.5 m
	JEPMC-W6002-01-E	1 m
	JEPMC-W6002-03-E	3 m
	JEPMC-W6002-05-E	5 m
	JEPMC-W6002-10-E	10 m
	JEPMC-W6002-20-E	20 m
	JEPMC-W6002-30-E	30 m
	JEPMC-W6002-40-E	40 m
	JEPMC-W6002-50-E	50 m
	MECHATROLINK Cable MECHATROLINK Connector – MECHATROLINK Connector (with Ferrite Core) 	JEPMC-W6003-A5-E
JEPMC-W6003-01-E		1 m
JEPMC-W6003-03-E		3 m
JEPMC-W6003-05-E		5 m
JEPMC-W6003-10-E		10 m
JEPMC-W6003-20-E		20 m
Terminator 	JEPMC-W6022-E	–

2.2.4 Connecting the RLY OUT Connector

The RLY OUT connector connects the status output terminal. It is an NO contact relay output. The RLY OUT connector is linked to the operation of the RDY indicator: The contacts close when the indicator lights, and they open when the indicator goes out.

The RLY OUT connector is provided only for MP2300 and MP2400.

Information When the RDY indicator is lit, the Controller is operating normally. It does not necessarily mean that the user programs are being executed.

RLY OUT Connector Specifications

The operation of the RLY OUT connector is linked to the operation of the RDY indicator on the CPU Module.

RDY indicator lit: Circuit closed

RDY indicator not lit: Circuit open

◆ Contact Ratings

Input Voltage	Current Capacity
24 VDC	0.5 A (resistive load) 0.25 A (inductive load)
125 VAC	0.4 A (resistive load) 0.2 A (inductive load)

RLY OUT Connector Connection Cable

To connect the RLY OUT connector, use a cable with a wire size of AWG28 to AWG14 (0.08 to 2.0 mm²) and a maximum outer diameter of 3.4 mm.

The procedure to make the RLY OUT connector cable is the same as for the 24-VDC power supply cable.

RLY OUT Connector Connection Example

Refer to the following figure for an example of connecting the RLY OUT connector.

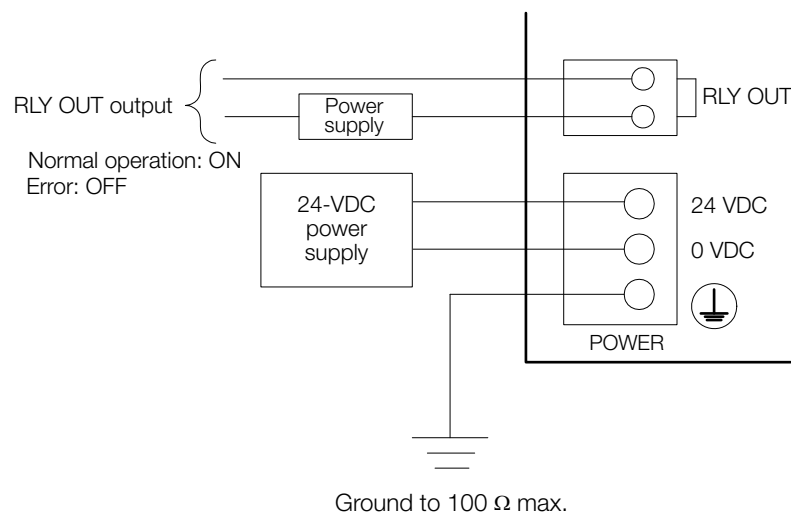

2.2.5 Connecting the Power Supply and Other Devices

Use the following procedure to connect the power cables that you made to the system devices.

1. **Connect the SERVOPACK to the Servomotor.**
Connect the motor cable, the encoder cable, and the ground terminals.
2. **Wire the power supply to the Machine Controller and the SERVOPACK.**
Refer to the following section for more information on wiring the power supply to the Machine Controller.
 [2.2.2 Connecting the Power Supply Connector on page 2-21](#)
 Note: Refer to the relevant manuals for information on wiring the SERVOPACK power supply.
3. **After wiring the power supply, turn ON the power, and confirm that power is being supplied.**
After confirmation, turn OFF the power supply.

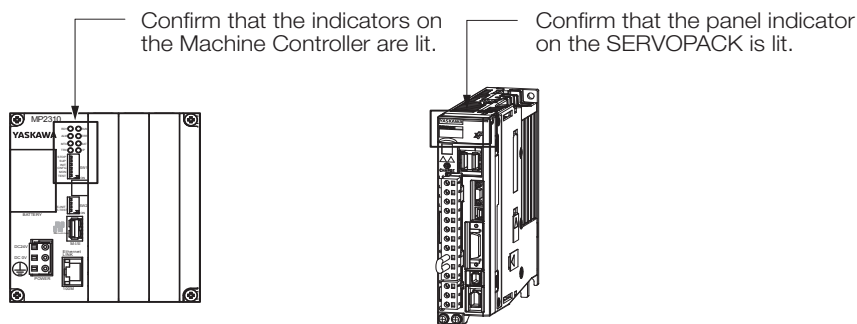

4. **Connect the devices using the MECHATROLINK-II or MECHATROLINK-III cables.**
Example: When using the MECHATROLINK-II

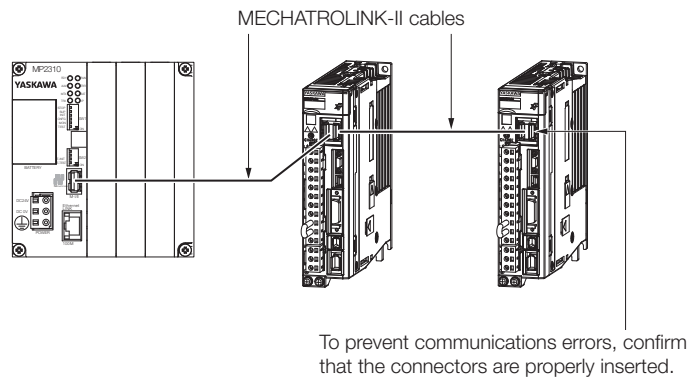

Note: 1. A MECHATROLINK-II Terminator is not required for using the MP2300, MP2310, or MP2400 Machine Controller.

2. If more than one SERVOPACK is connected with MECHATROLINK-II Communications Cables, install a Terminator on the last SERVOPACK.

5. **Set the station addresses of the SERVOPACKs.**

Example The following is an example of the station address settings.
 MECHATROLINK-II: The figures show the settings when the address of axis 1 is 1, and the address of axis 2 is 2.
 MECHATROLINK-III: The figures show the settings when the address of axis 1 is 3, and the address of axis 2 is 4.

Note: For MECHATROLINK-III, start setting the station addresses from 3.

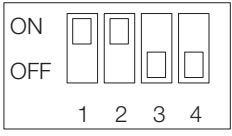
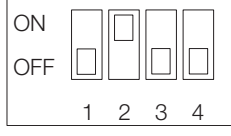
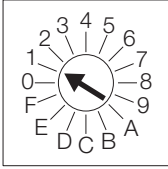
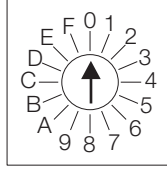
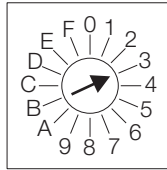
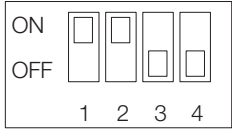
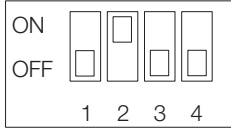
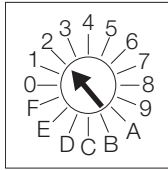
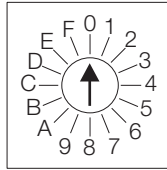
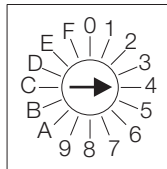
SERVOPACK		MECHATROLINK-II	MECHATROLINK-III	
Axis 1	SW2		S3	
	SW1		S1	
	-	-	S2	
Axis 2	SW2		S3	
	SW1		S1	
	-	-	S2	

Machine Controller Setup

3

This chapter provides the procedures for setting up a Machine Controller using the MPE720.

3.1	The Flow of the Setup	3-2
3.2	MPE720 Installation	3-3
3.3	Creating a Project File	3-13
3.3.1	Project Files	3-13
3.3.2	Creating a Project File	3-14
3.3.3	Setting a Project Password	3-17
3.4	Self Configuration	3-18
3.5	Placing the MPE720 Online	3-20
3.5.1	Preparing the Ethernet Connection	3-20
3.5.2	Project Link Connection	3-25
3.6	Device-specific Settings	3-29
3.6.1	Data That Is Automatically Updated during Self Configuration	3-29
3.6.2	Detailed Module Settings	3-31
3.6.3	Parameters Updated during Self Configuration	3-40
3.6.4	Setting Machine-specific Motion Parameters	3-42
3.6.5	Calendar Feature	3-51
3.6.6	Setting the Scan Times	3-52
3.7	Test Run	3-54
3.7.1	Test Run	3-54
3.7.2	Starting the Test Run and Selecting the Axis	3-55
3.7.3	Test Run Dialog Box Details	3-57

3.1 The Flow of the Setup

The following flowchart shows the setup procedures.

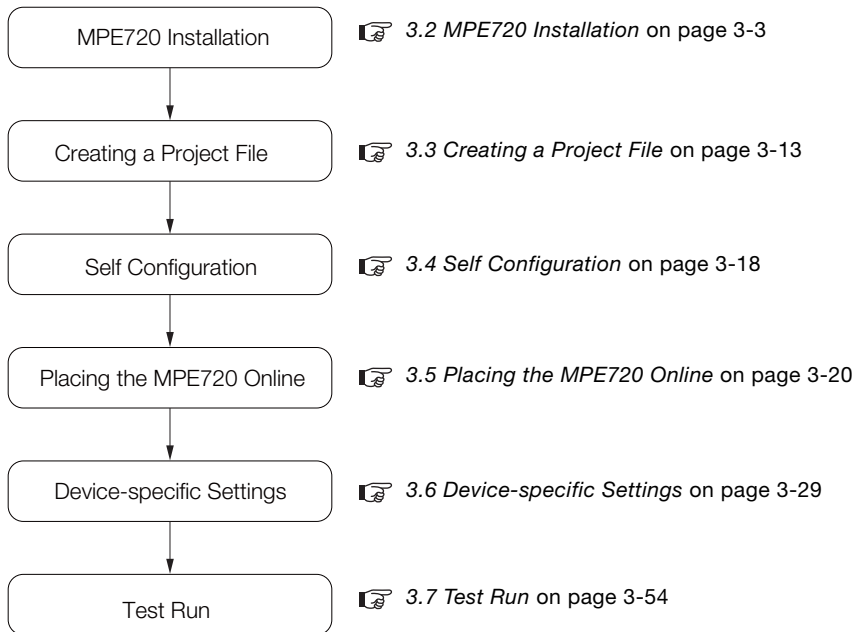

3.2 MPE720 Installation

Use the following procedure to install the MPE720.

Refer to the following brochure or the catalog for details on the system requirements of the MPE720.

📖 MP2000-series Machine Controller (Manual No.: KAEP C880700 15)



Term

What Is the MPE720?

It is the Engineering Tool that you use to design and maintain Machine Controller applications. It provides an environment to design applications by dragging and copying, as well as to share, reuse, and save data efficiently.

1. Insert the MPE720 installation DVD into the PC.
The Installer will start automatically.
2. Execute the Setup.exe file in the folder.
When execution of Setup.exe starts, the Welcome to the World of Motion... Dialog Box will be displayed.
3. Click the **Install** Button for MPE720 Ver. 7.

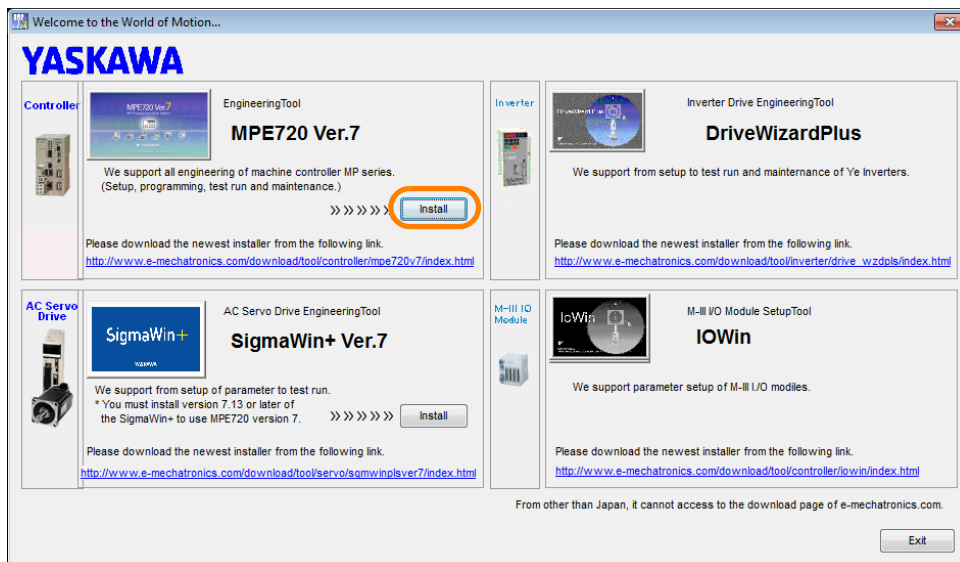

When the application is ready to be installed, the YASKAWA MPE720 Ver. 7 - InstallShield Wizard Dialog Box will be displayed.



Note

If .NET Framework 4.5 or higher is not installed on the PC, the following dialog box will be displayed. If that occurs, execute the dotnetfx45_full_x86_x64.exe file in the DVD folder to install it and then execute step 2 again.

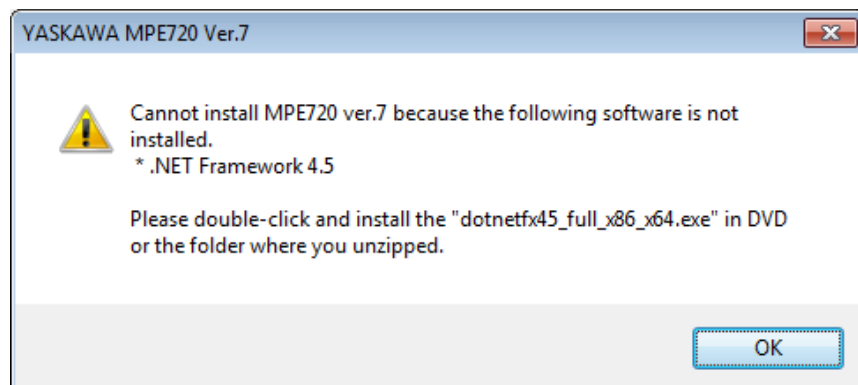

4. Click the Next Button.

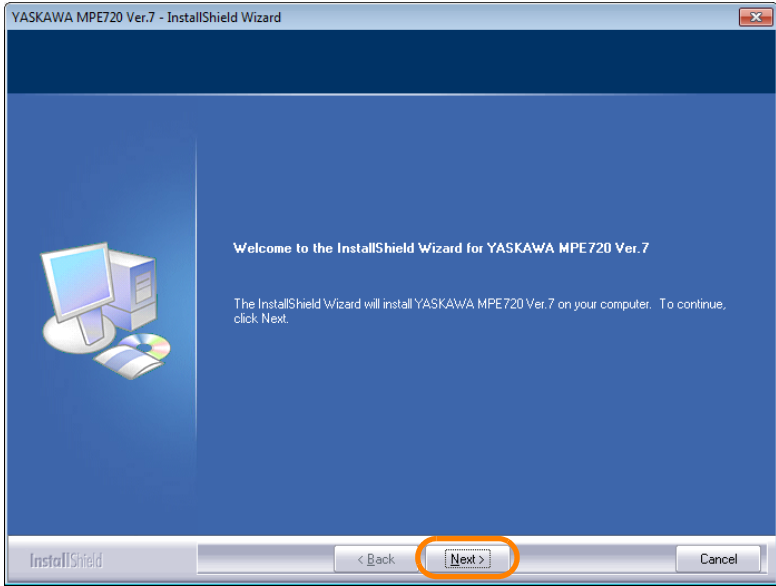

The License Agreement will be displayed.

5. Read the agreement, and then select the I accept the terms of the license agreement Option.

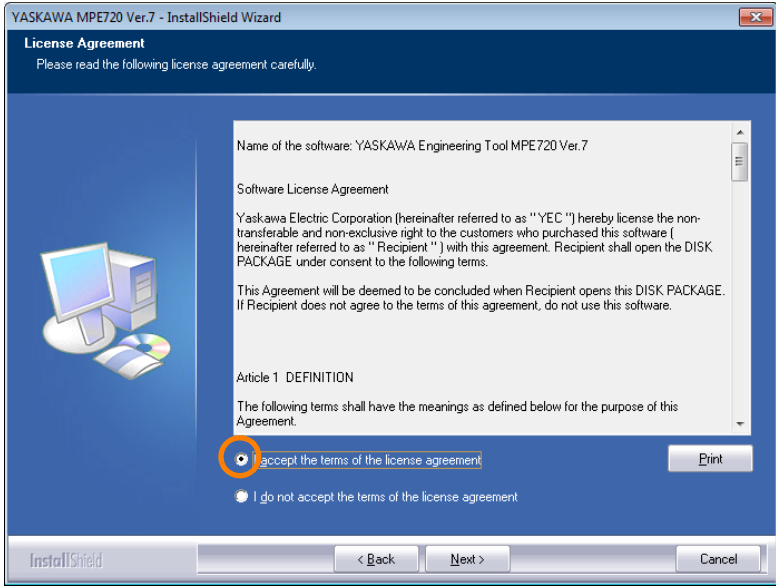

6. Click the Next Button.

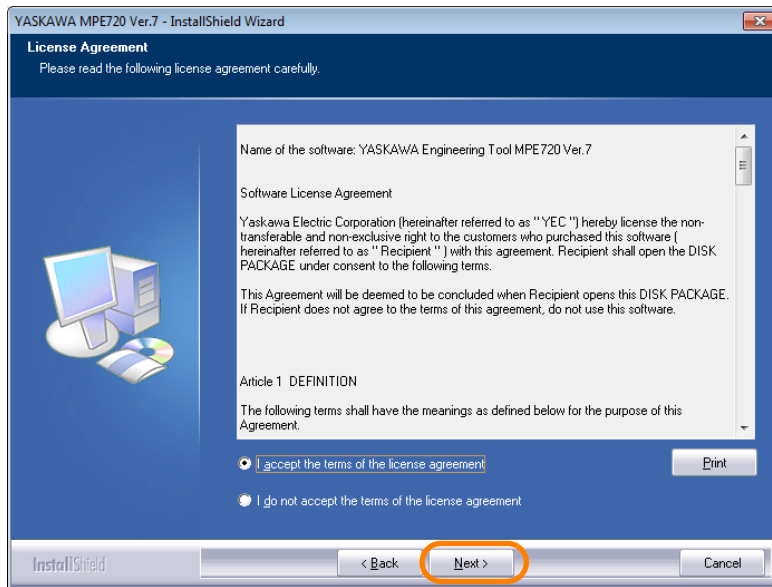

7. Enter the following information.

- User Name
- Company Name
- Serial Number: Enter the number that is printed on the DVD package.

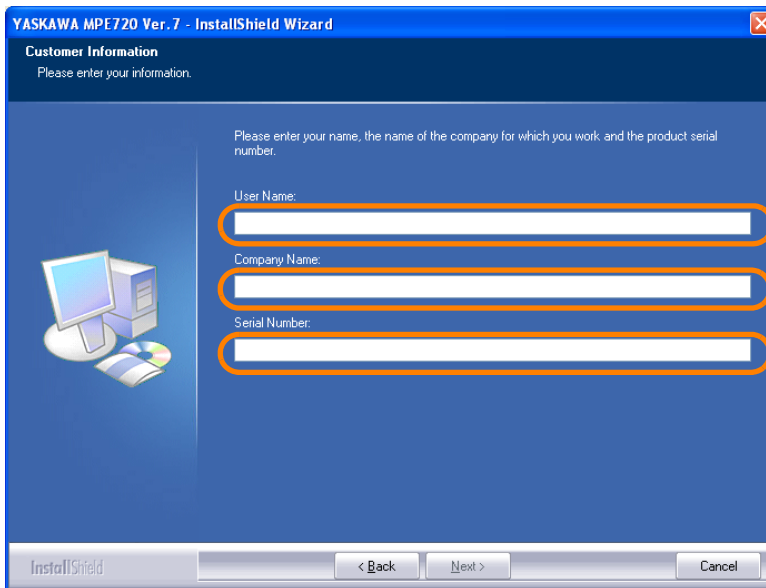

8. Click the Next Button.

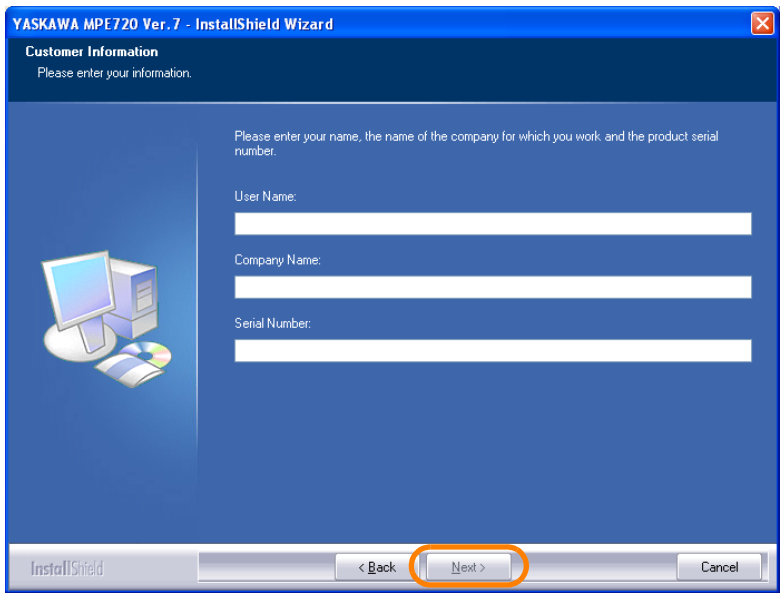

9. Select the destination folder.

- To install to the folder shown under **Destination Folder**: Proceed to step 10.
- To change the destination folder: Click the **Browse** Button and select the desired destination by following the guidance displayed in the dialog box.

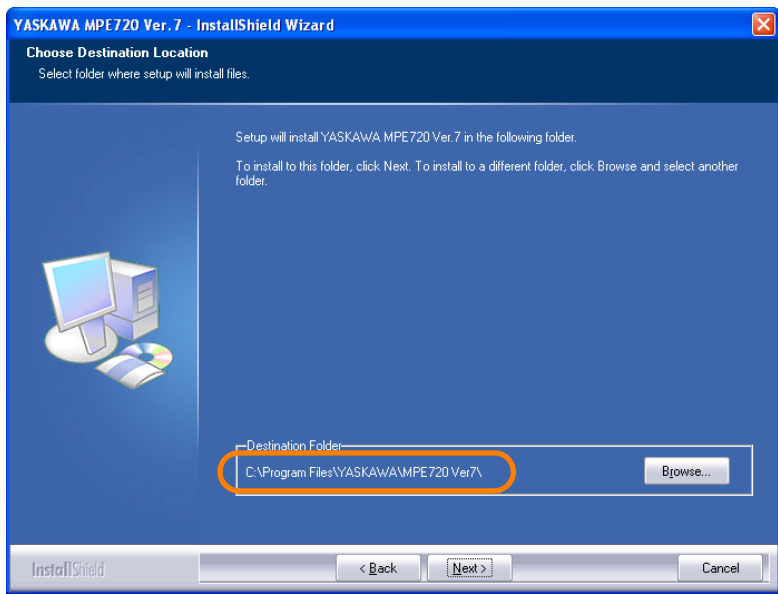

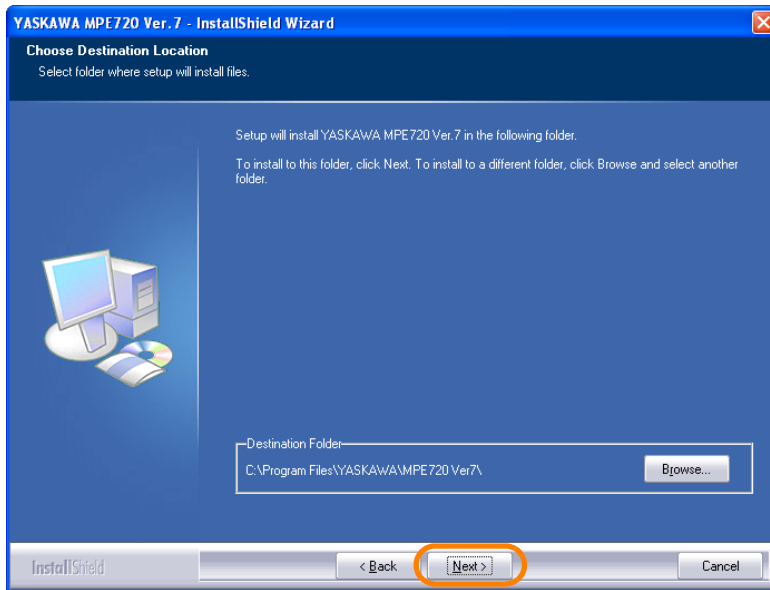
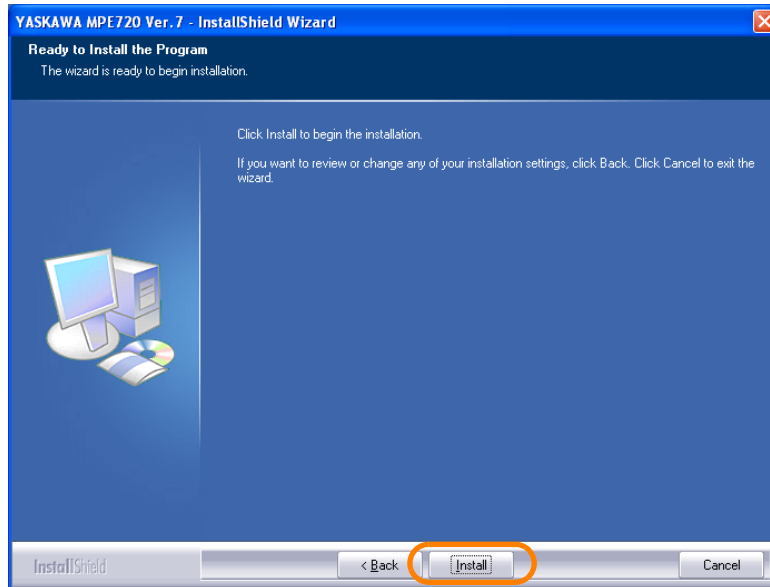
10. Click the Next Button.**11. Click the Install Button.**

The installation will begin.

12. Click the Finish Button.

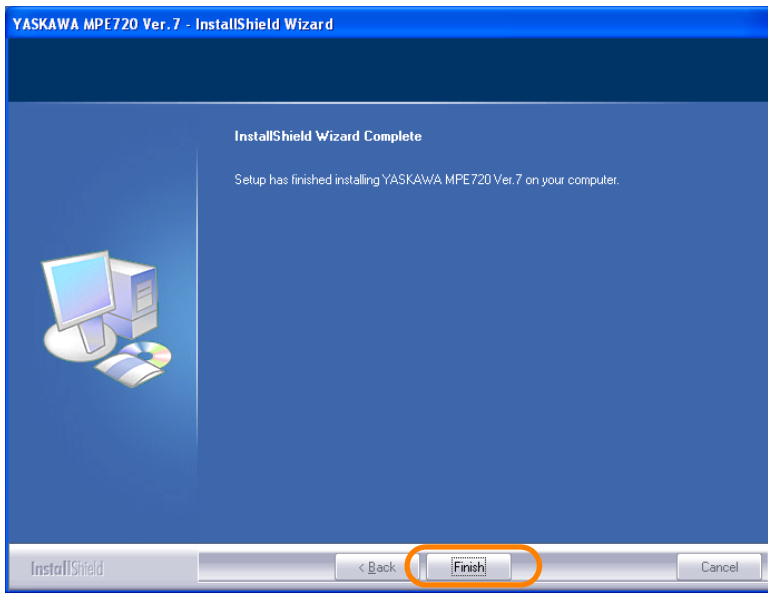

This concludes the installation of the MPE720 on the PC. Installation of SigmaWin+ Ver. 7 will start next in the following cases. Proceed to step 13.

- SigmaWin+ Ver. 7 is not installed in the PC.
- The version of SigmaWin+ Ver. 7 installed in the PC is lower than version 7.13.
- The version of SigmaWin+ Ver. 7 installed in the PC is higher than version 7.13, but the version on the DVD is higher than the installed version.

13. The following dialog box will be displayed. Click the OK Button.

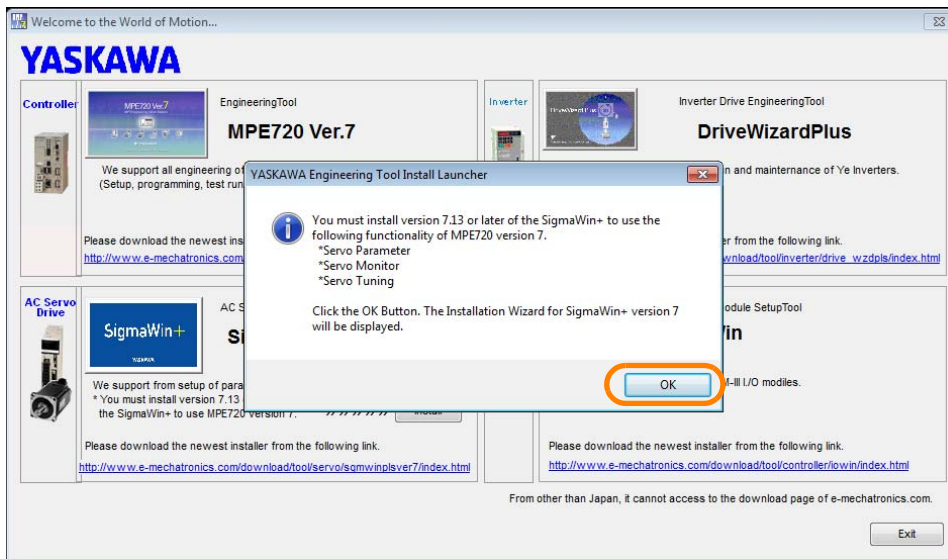

The Installer will start automatically.

14. Click the Install Button for SigmaWin+ Ver. 7.

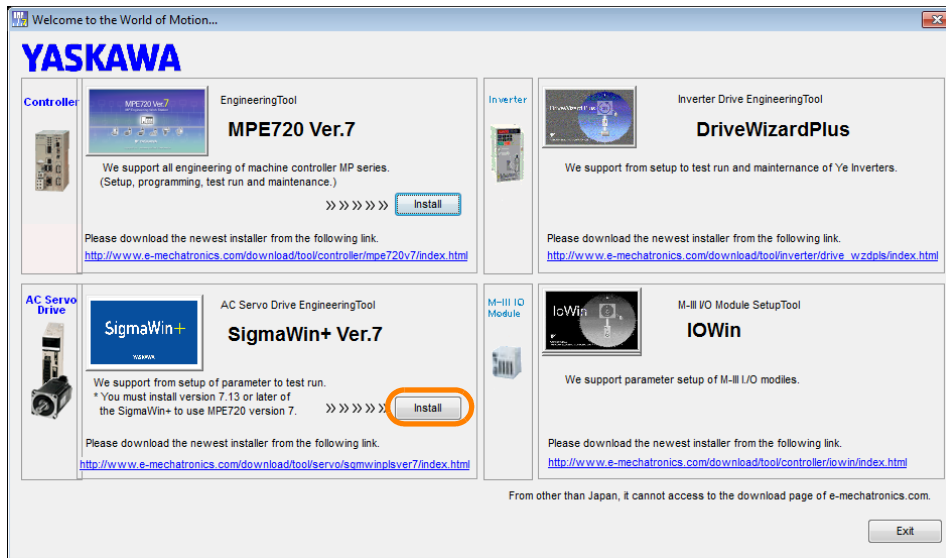

When the application is ready to be installed, the YASKAWA SigmaWin+ Ver. 7 - InstallShield Wizard Dialog Box will be displayed.

15. Click the Next Button.

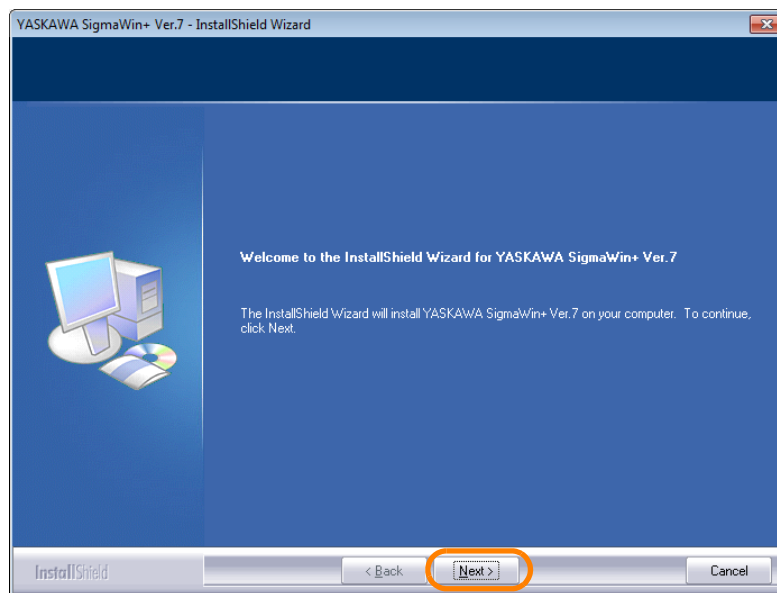

The License Agreement will be displayed.

16. Read the agreement, and then select the I accept the terms of the license agreement Option.

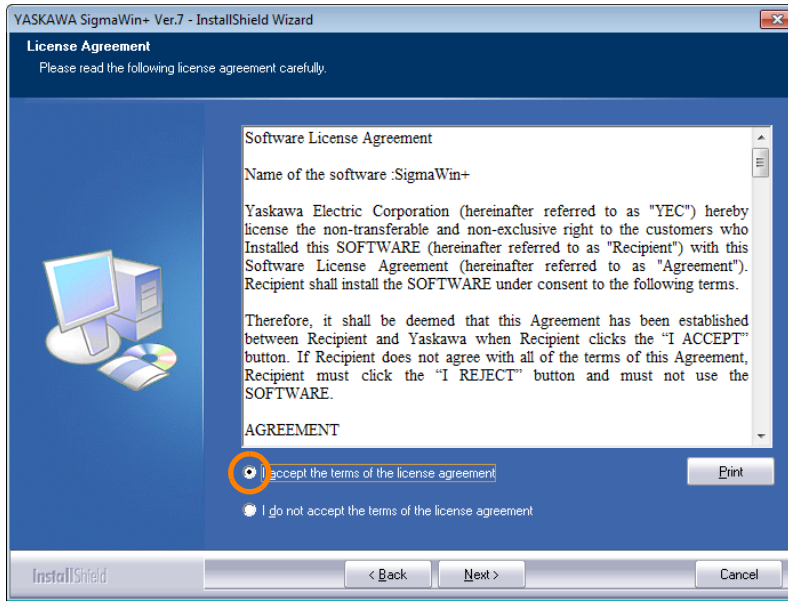

17. Click the Next Button.

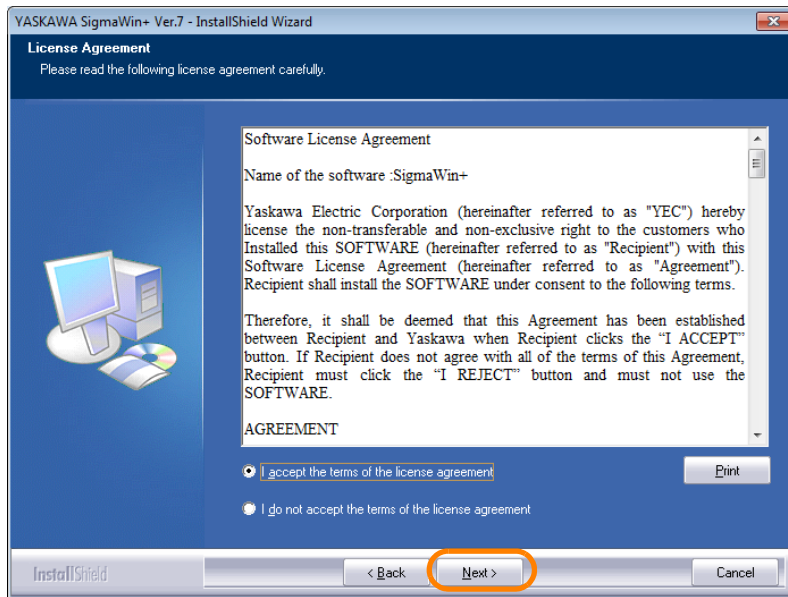

18. Select the destination folder.

- To install to the folder shown under **Destination Folder**: Proceed to step 19.
- To change the destination folder: Click the **Browse** Button and select the desired destination by following the guidance displayed in the dialog box.

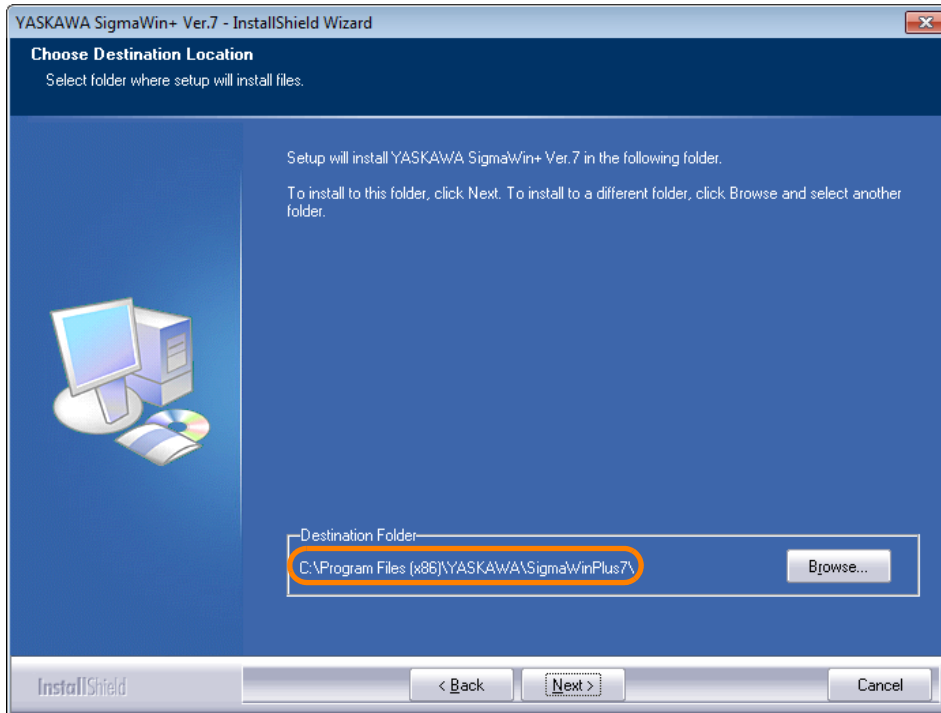
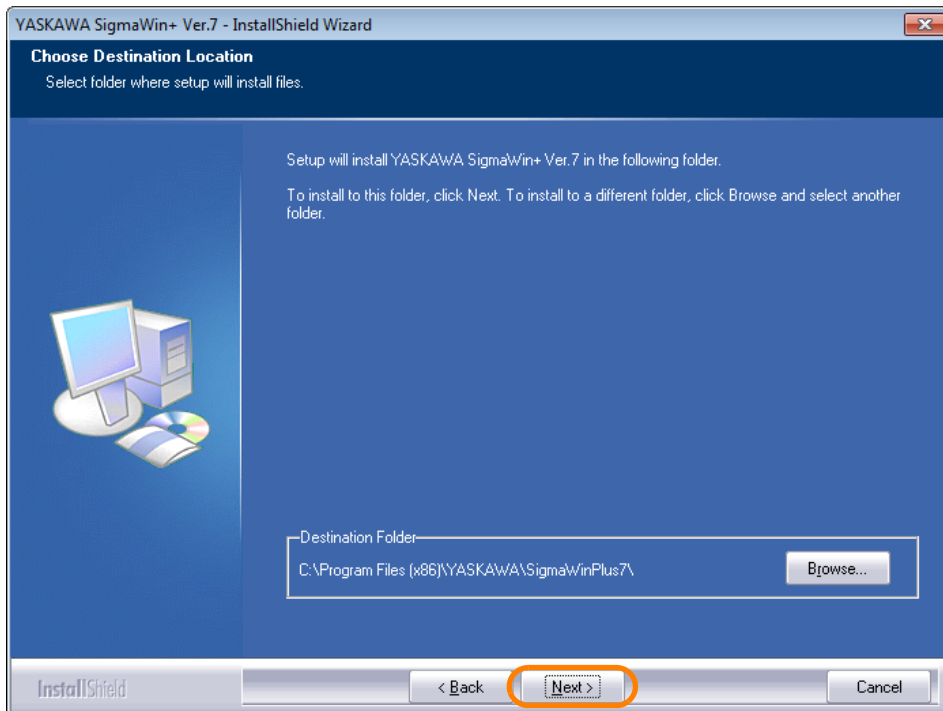
**19. Click the Next Button.**

20. Click the Install Button.

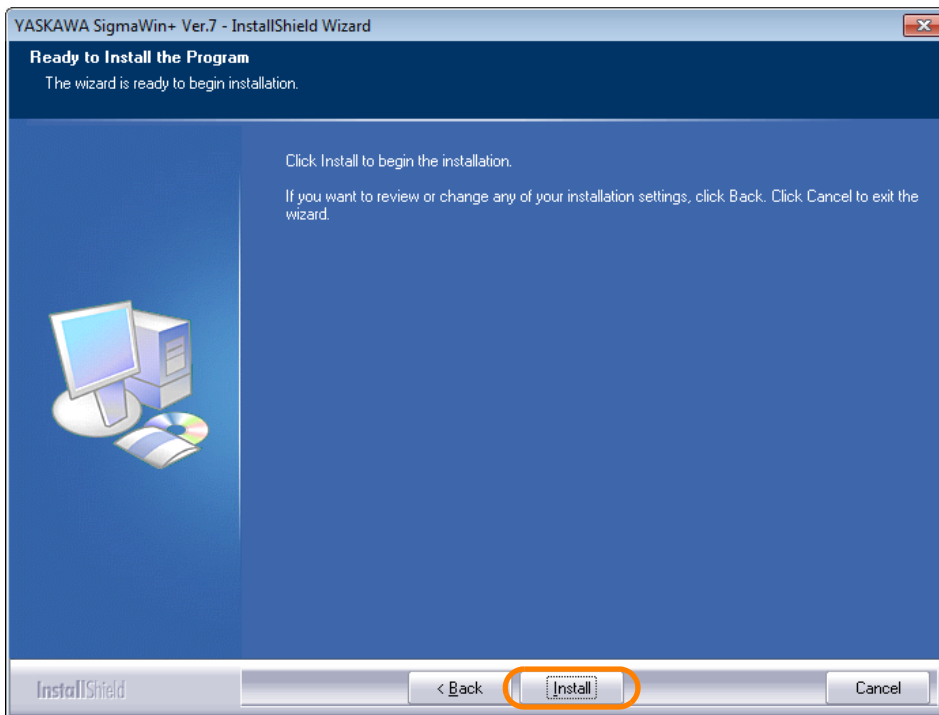

The installation will begin.

21. Click the Finish Button.

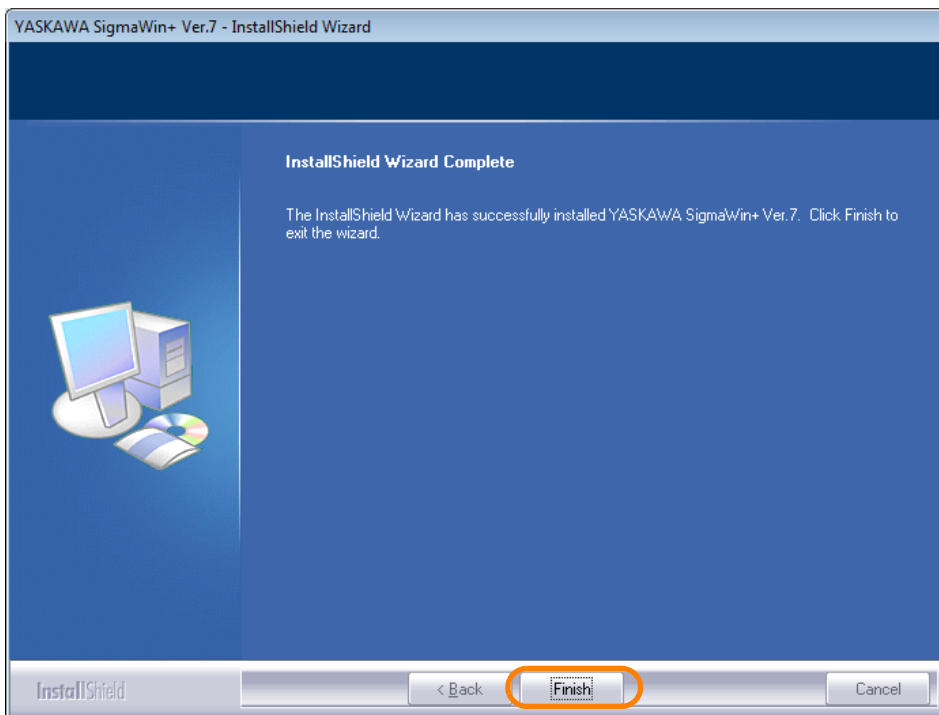

This concludes the installation of SigmaWin+ Ver. 7 on the PC.

3.3 Creating a Project File

This section gives the procedure for creating a project file.

3.3.1 Project Files

A project file is the application file for MPE720 version 7. It includes the following information.

System configuration	<ul style="list-style-type: none"> • System definitions • Scan time definitions • Module configuration definitions • Data tracing information
Programs	<ul style="list-style-type: none"> • Ladder programs (high-speed, low-speed, start, interrupt, and function programs) • Motion programs (main program, subprograms, and group definitions) • Table data • Variables (axis, I/O, global, constant, and user-defined structure variables) • Comments (I/O, global, and constant comments)
Registers	<ul style="list-style-type: none"> • M (data registers) • D (internal registers) • C (constant registers) • S (system registers) • I (input registers) • O (output registers)

The project file includes files for all of the above information but allows you to handle them as a single file in Windows. The project file extension is .YMW7.

Opening a project file enables editing all of these files.

Only one project file can be opened in a single window with MPE720 version 7. The same project file cannot be opened in more than one window with MPE720 version 7. If you try to open a project file that is already open, the window that contains the open project file will move to the front.

Information You can also use project files that were created on MPE720 Version 6.0 (extension “.YMW”). Select the “.YMW” extension if you need to also use the project file on version 6.

Information To prevent data loss in case of a CPU Module failure, always store a backup copy of the project file. We recommend saving a copy of the project file before making any modifications to it (changing the module configuration definitions, the ladder programs, the motion programs, etc.).

3.3.2 Creating a Project File

Use the following procedure to create a project file.

Information Project files are created when the MPE720 is offline.

1. If the MPE720 is online, click the **Connection/Disconnection** Button on the My Tool View of the Start Tab Page.

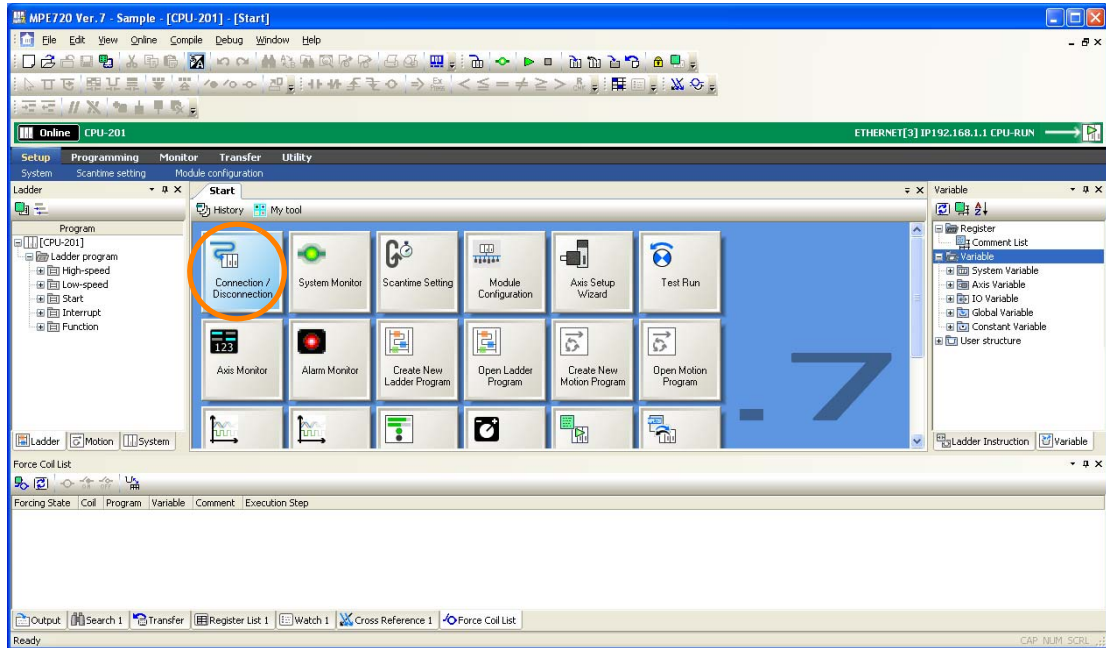

The MPE720 Ver. 7 Dialog Box will be displayed.

2. Click the **Yes** Button.

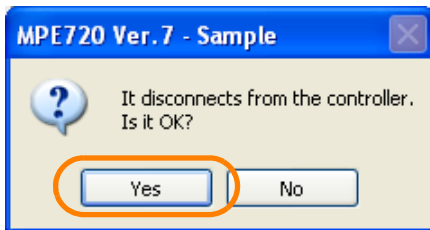

Communications between the MPE720 and the Machine Controller will be disconnected, and the History View will be displayed.

3. Start creating a project file with either of the following two methods.
 - Hold down the **Ctrl** Key and press the **N** Key.
 - Select **New** from the **Project Area**.

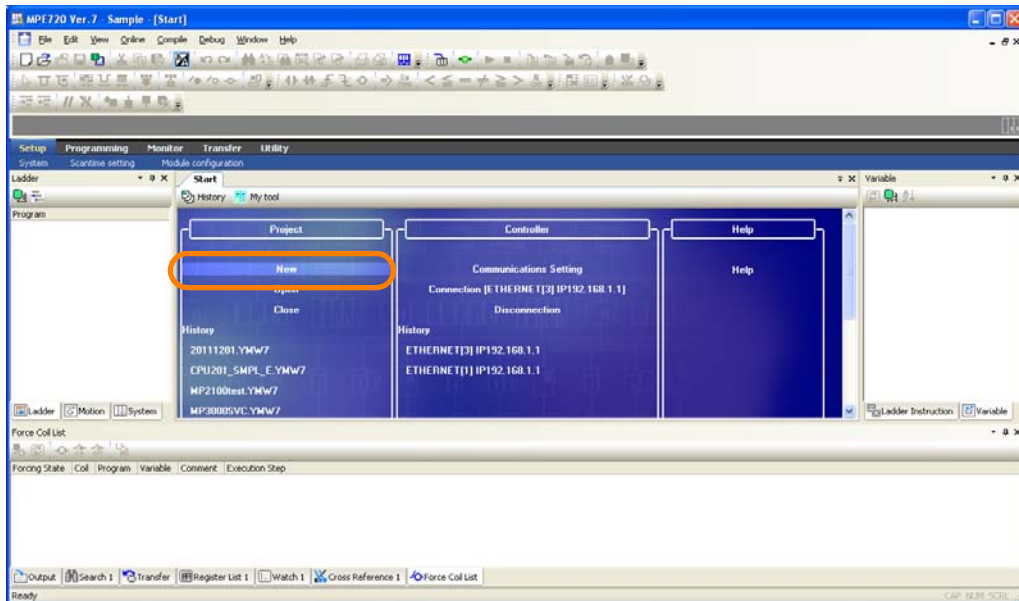

- Select **File – New Project** from the menu bar.

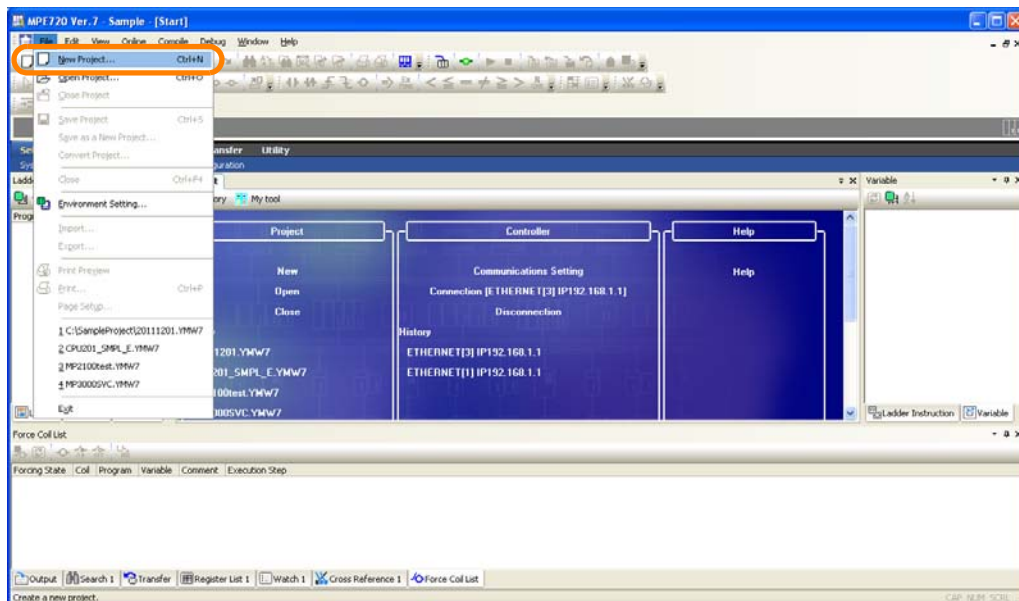

Information If there is an edited file, a message will be displayed asking whether the file is to be compiled and saved. The result of clicking each of the buttons is described below.

Yes Button: The current project will be compiled and saved by overwriting the previous version, and editing will be ended.

No Button: Editing will be ended without compilation and saving any changes.

Cancel Button: Creating a project will be canceled and you can continue to edit the current project.

The Create New Project Dialog Box will be displayed.

4. Enter the information from ① to ⑤.

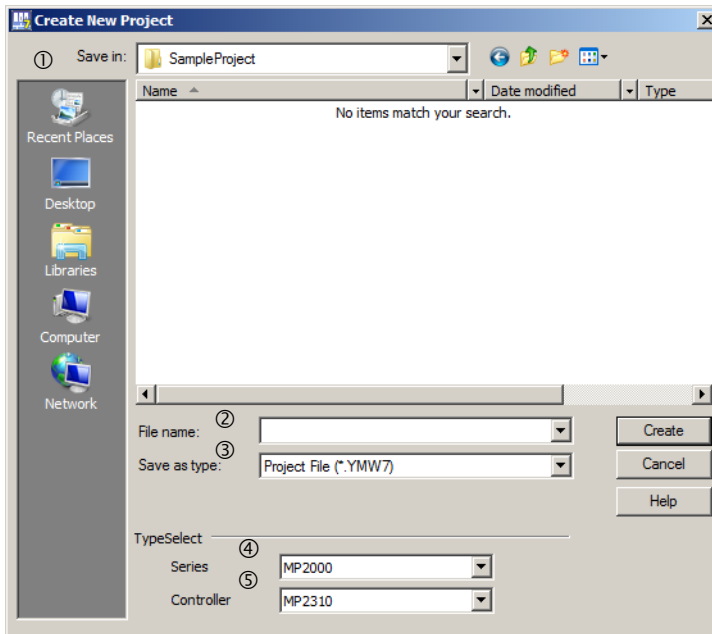

No.	Item	Description
①	Save in	Select the folder in which to save the project file data.
②	File name	Enter the name of the project file to create. Note: The file name cannot contain any of the following characters: / \ : * ? " < >
③	Save as type	Select the file extension for the project file. Either .YMW or .YMW7 can be selected.
④	Series	Select the series of the Machine Controller to use.
⑤	Controller	Select the model of the CPU Unit.

5. Click the **Create** Button.

A message will be displayed saying, "The project file will be created and opened." The project file will be created in the specified folder and the new project file name will be displayed in the Ladder Pane, Motion Pane, and System Pane.

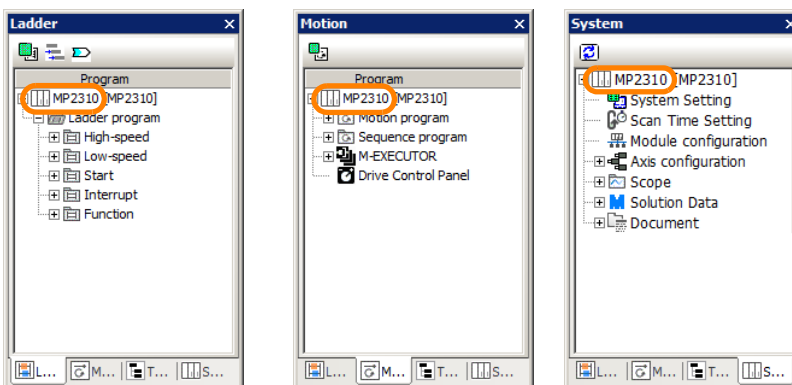

This concludes the procedure.

Make the following settings after you create a project file.

- Communications settings
- Module configuration settings
 - ☞ 3.6 Device-specific Settings on page 3-29
- System settings
- Scan settings
 - ☞ Setting the Scan Times (page 3-52)

After you create a project file, you can perform program file operation in the Ladder and Motion Panes.

Information

- Opening an Existing Project File

You can open an existing project files by dragging its icon to the window of MPE720 version 7. Alternatively, select **File – Open Project** from the menu bar to display the Open Project Dialog Box, and then select and open the project file from there.

Note: If another project file is already open in the same window, and there were changes made to it, then performing the operation above will display a dialog box asking whether to save the changes to the project file.

- Saving a Project File

A project file can be saved so that it overwrites the previous version. Select **File – Save Project** from the menu bar. A message will be displayed asking you to wait while the project file is being saved. The edited project file is saved by overwriting the previous version of it. To save the project file with a different name, select **File – Save as a New Project** from the menu bar.

- Closing a Project File

To close a project file, select **File – Close Project** from the menu bar. Alternatively, select *Close* from the Project Menu on the Start Tab Page.

3.3.3 Setting a Project Password

You can set a password for the project file that is currently open.

Refer to the following chapter for details.

 *Chapter 6 Security*



Important

If you forget the password that you set, there is no way to recover it, and it will be impossible to open the password-protected project file. Therefore, if you set a password, make sure you do not forget it.

3.4 Self Configuration

Self configuration is a feature that automatically recognizes all the Optional Modules that are installed in the Machine Controller and all the slave devices that are connected via the MECHATROLINK connector (such as Servo Drives), and creates the module configuration definition files based on that information.

When self configuration is performed, the following information is changed.

- Modules that are installed in the Machine Controller are assigned
- Slave devices that are connected via MECHATROLINK communications are assigned
- All user programs are cleared
- All registers are newly assigned
- Some of the SERVOPACK parameters are automatically updated

Refer to the following section for details on parameters.

 [3.6.3 Parameters Updated during Self Configuration on page 3-40](#)

There are two ways of performing self configuration.

- Self configuration using DIP switches
- Self configuration procedure using MPE720

Refer to the following manual for details on the self configuration procedure using MPE720.

 [Machine Controller MP2000/MP3000 System Engineering Tool MPE720 Version 7 USER'S MANUAL \(Manual No.: SIEP C880761 03\)](#)

When performing self configuration for the first time after connecting devices or when the Machine Controller has been initialized, perform self configuration using DIP switches.

In other cases, either method is acceptable.

Use the following procedure to execute the self configuration using the DIP switch on the MP2000/MP3000-series Machine Controller.

1. Check the following points.

- The power supply to the Machine Controller must be OFF.
- The power supply to all components that are not part of the Machine Controllers, such as SERVO-PACKS, must be ON.

2. Turn ON only the INIT and CNFG pins on the DIP switch (SW1) on the Machine Controller.

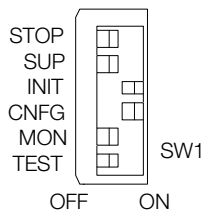

Information

1. INIT Pin

If the power supply to the Machine Controller is turned ON while the INIT pin is set to ON, all of the following data will be deleted from the Machine Controller.

- Definition files
- User programs
- Registers

2. CNFG Pin

If the power supply to the Machine Controller is turned ON while the CNFG pin is turned ON, the self configuration will begin and all of the following data will be created and/or updated.

- Definition files: Created again or updated.
- User programs: Not affected by ON/OFF state of CNFG pin.
- Registers: Not affected by ON/OFF state of CNFG pin.

3. Turn ON the power supply to the Machine Controller.

Self configuration will be executed.

4. Confirm that the indicators on the Machine Controller change in the following way:
 - RDY: Goes out, and then lights.
 - RUN: Goes out, flashes, and then lights.
5. Turn OFF the INIT and CNFG pins on the DIP switch (SW1) on the Machine Controller.

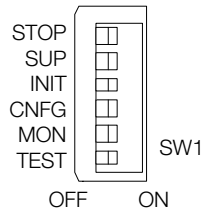

This concludes the settings.



Important

1. INIT Pin on the DIP Switch and RAM Data

If the power supply is turned OFF and ON again when the INIT pin on the Machine Controller SW1 DIP switch is set to ON, the RAM data will be cleared.

If the power supply is turned OFF and ON again while the INIT pin is set to OFF, the data from the flash memory will be loaded and the RAM data will be overwritten with it. Therefore, if the power supply must be turned OFF while writing or editing a program, make sure you save the data to the Machine Controller's flash memory to protect the RAM data.

2. Power Interruptions after Self Configuration

After performing self configuration, turn OFF the power supply to the Machine Controller only after the definition data is saved to the flash memory of the Machine Controller.

If by chance the power supply is turned OFF before the data is saved, perform self configuration again.

Refer to the following section for details on saving data to the flash memory.

 [4.5.5 Saving to Flash Memory](#) on page 4-65

3.5 Placing the MPE720 Online

This section describes how to go online.

 **Term**

Going online refers to connecting the MPE720 to the Machine Controller. There are two ways of placing the MPE720 online.

- **Project link connection**
Open a project file, and connect the MPE720 Machine Controller. Refer to the following section for details.
 [3.5.2 Project Link Connection on page 3-25](#)

Information that is changed with a project link connection established is saved to the project file.
To save the information to the Machine Controller, too, follow the procedure below.

1. Click [Transfer] in the My Tool View.
2. Click [Write into Controller].

- **Direct connection**
Connect the MPE720 to the Machine Controller without opening a project file. The operation procedure is as follows:
Select **Communications Setting** without opening a project file. The procedure from here on is the same as for a project link connection. The information of the module configuration definition that has been changed with a direct connection established is written into the Machine Controller. Program data is saved to the flash memory of the Machine Controller. Refer to the following section for details on how to save to flash memory.
 [4.5.5 Saving to Flash Memory on page 4-65](#)

3.5.1 Preparing the Ethernet Connection

Use the following procedure to prepare the Ethernet connection.

1. Use an Ethernet cable to connect the Ethernet connector on the Machine Controller to the LAN connector on the PC.

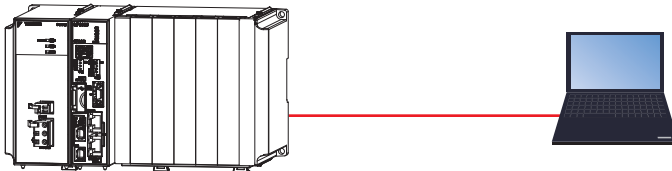

Information Use a cross cable for the Machine Controller if you connect the Machine Controller directly to the PC.

2. Click **Settings – Network Connections** from the Windows Start Menu.

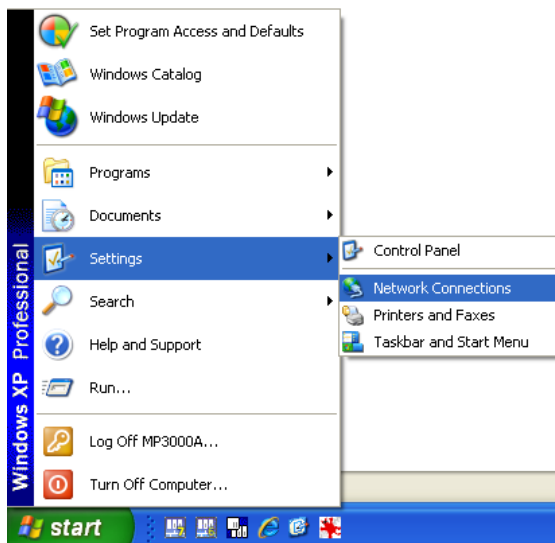

The Network Connections Window will appear.

3. Double-click **Local Area Connection**.

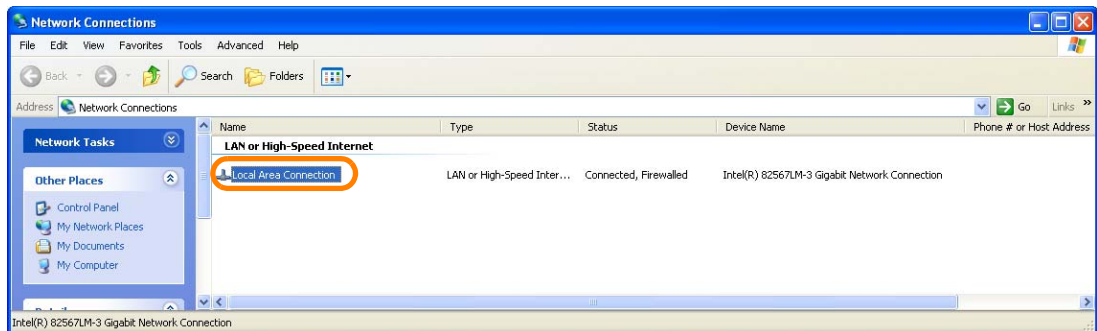

The Local Area Connection Status Dialog Box will be displayed.

4. Click the **Properties** Button on the General Tab Page.

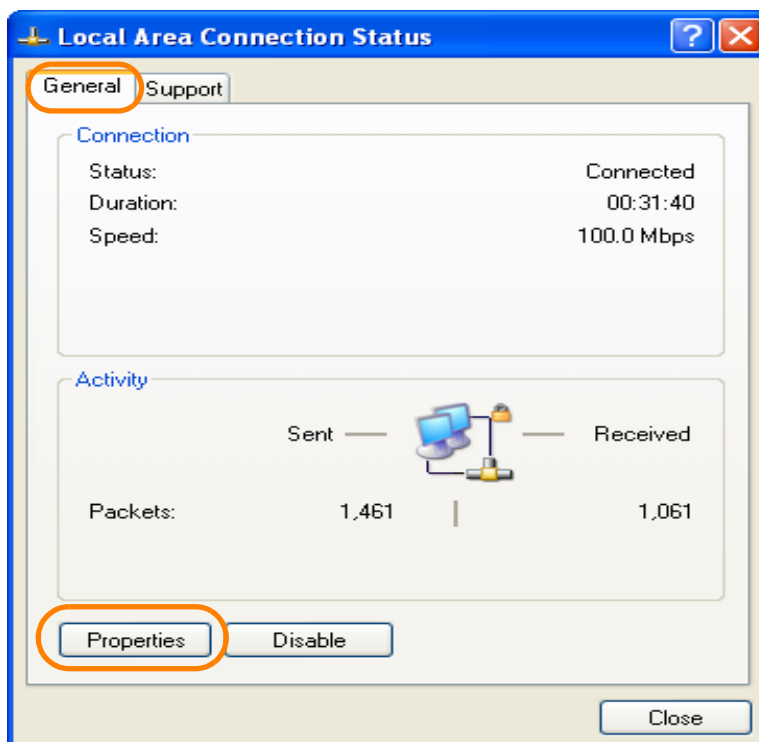

The Local Area Connection Properties Dialog Box will be displayed.

5. Double-click **Internet Protocol (TCP/IP)** in the **This connection uses the following items** Box.

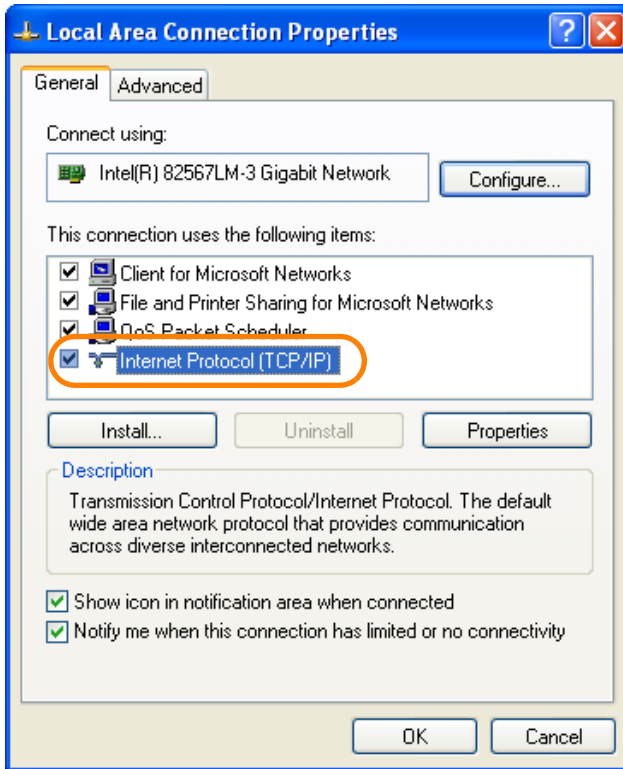

The Internet Protocol (TCP/IP) Properties Dialog Box will be displayed.

6. Select the **Use the following IP address** Option.

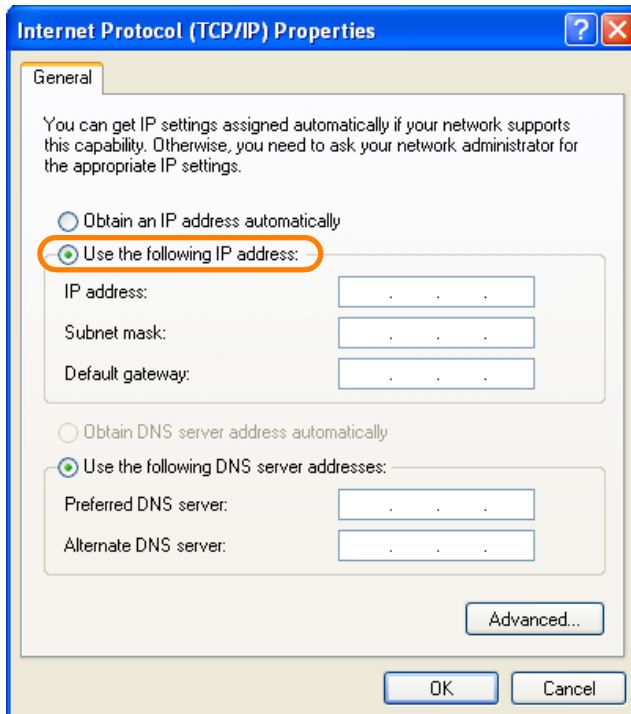

7. Enter the following information.

- IP address = 192.168.1.□□□
- Subnet mask = 255.255.255.0

Information Do not use the same IP address as the IP address of the Machine Controller. The default IP address of the Controller is 192.168.1.1. Therefore, the IP address of the MPE720 must be set to 192.168.1.* (where * is a value between 2 and 254).

Information It is not necessary to change or specify the default gateway.

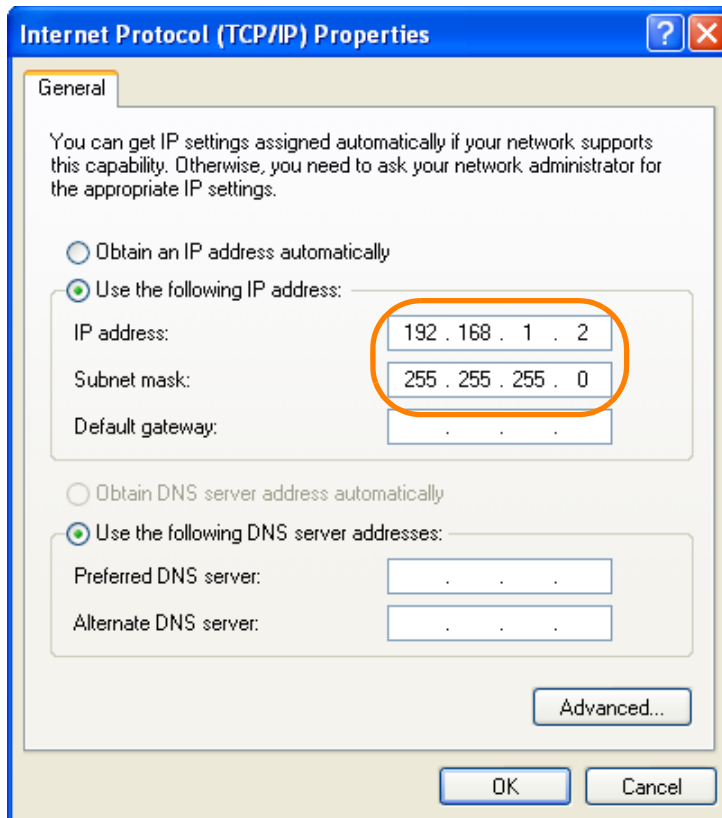

8. Click the **OK** Button.

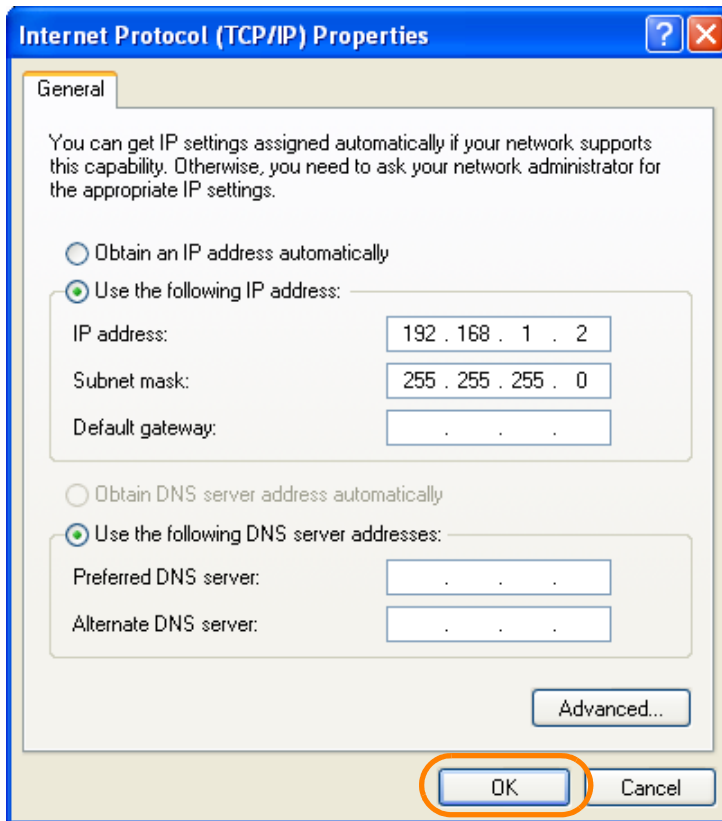

This concludes setting the IP addresses. The Internet Protocol (TCP/IP) Properties Dialog Box will close.

9. Click the **Close** Button in the following dialog boxes and windows.

- Network Connections Window
- Local Area Connection Properties Dialog Box
- Local Area Connection Status Dialog Box

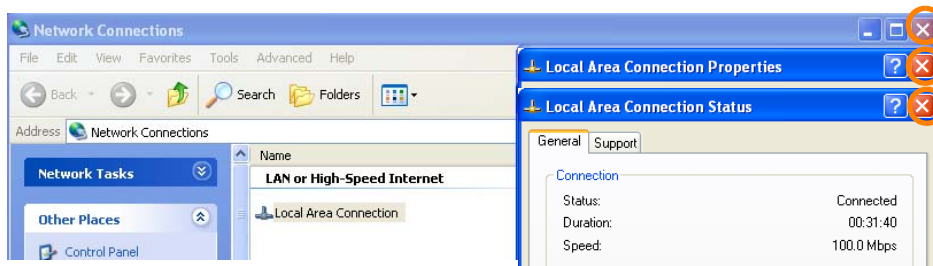

3.5.2 Project Link Connection

This section gives the procedure to create a project link connection.



Term

A project link connection refers to connecting the MPE720 that has an open project file to the Machine Controller.

1. Double-click the **MPE720 Ver. 7** Icon.



The MPE720 will start and the MPE720 Ver. 7 Window will appear.

2. Select **Open**.

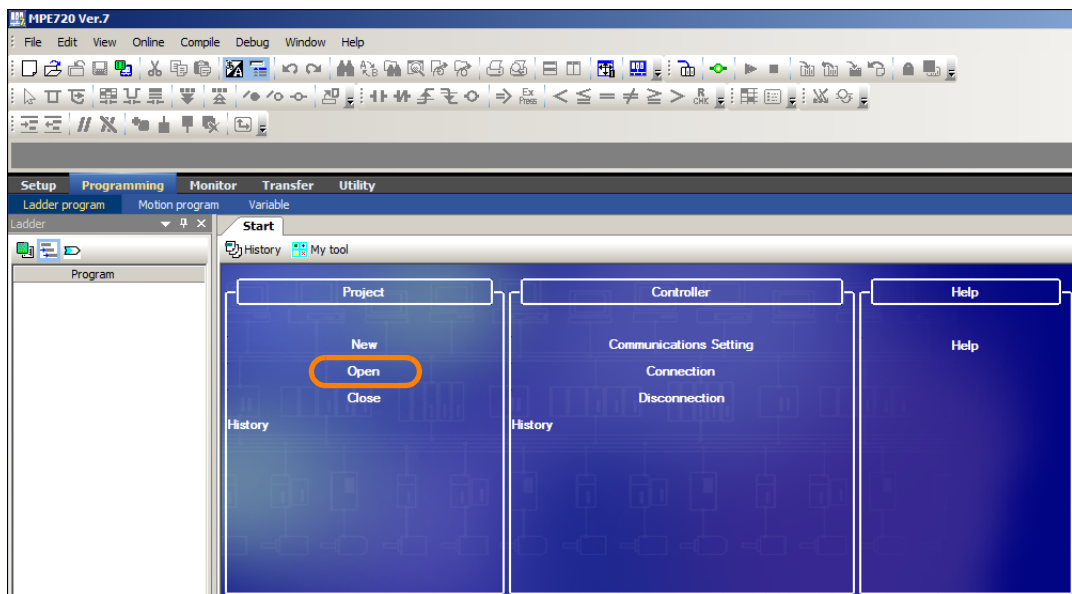

3. Select the project file to be opened to click the **Open** Button.

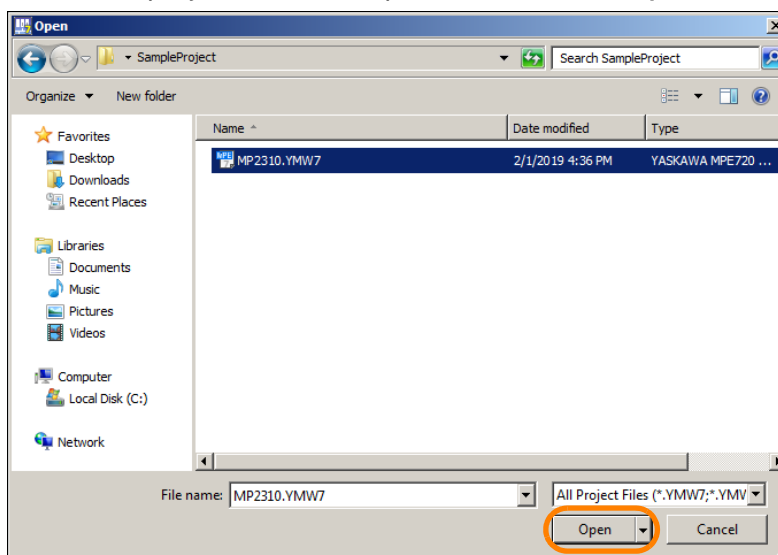

- Click the **Connection/Disconnection Button** on the My Tool View.

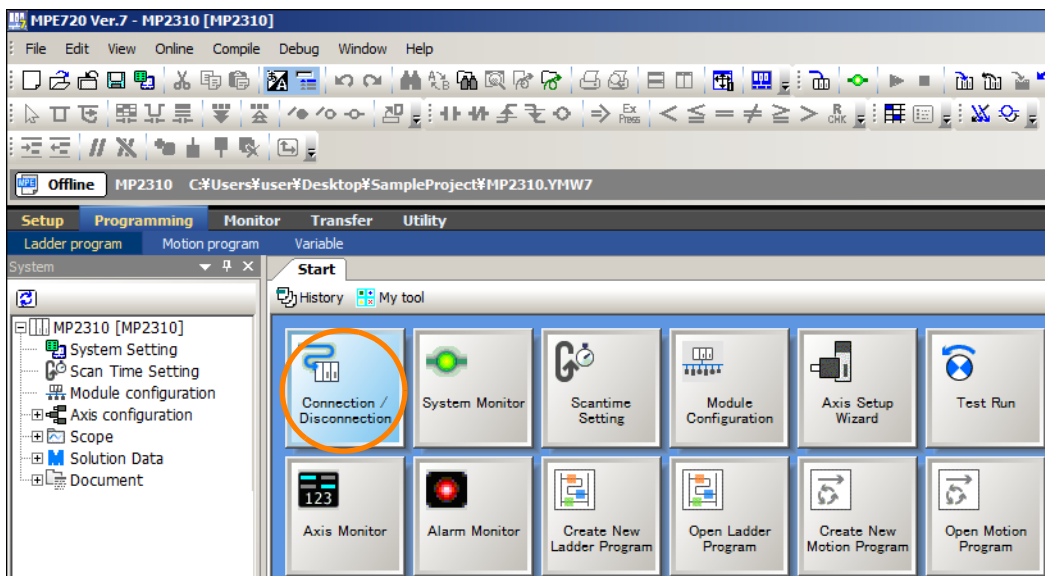

The Communications Setting Dialog Box will be displayed.

- Select the IP address that was set in the PC from the list of ports in the **Communication port** Box.

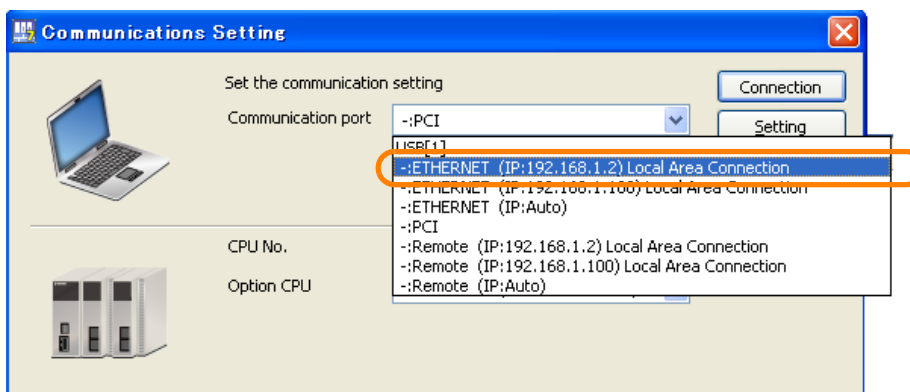

- Click the **Search Button**.

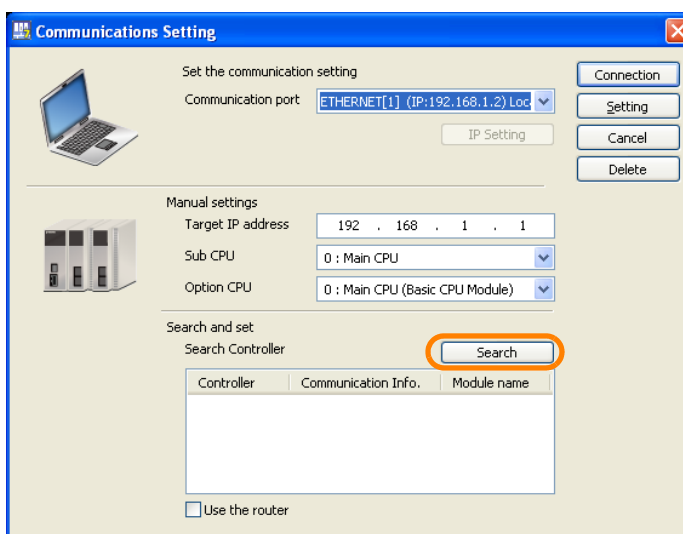

The search results will be displayed in the **Search Controller** Box.

Information If the MPE720 is connected to a Sub CPU Unit, "CPU-201SUB" will be displayed in the **Controller** Column.

- Select the Machine Controller that is directly connected to the MPE720 from the **Search Controller Box**.



Note

If you are using more than one CPU Unit together, Click the **+** icon in the **Controller** Column and then double-click the Machine Controller that is directly connected to the MPE720 to select it.

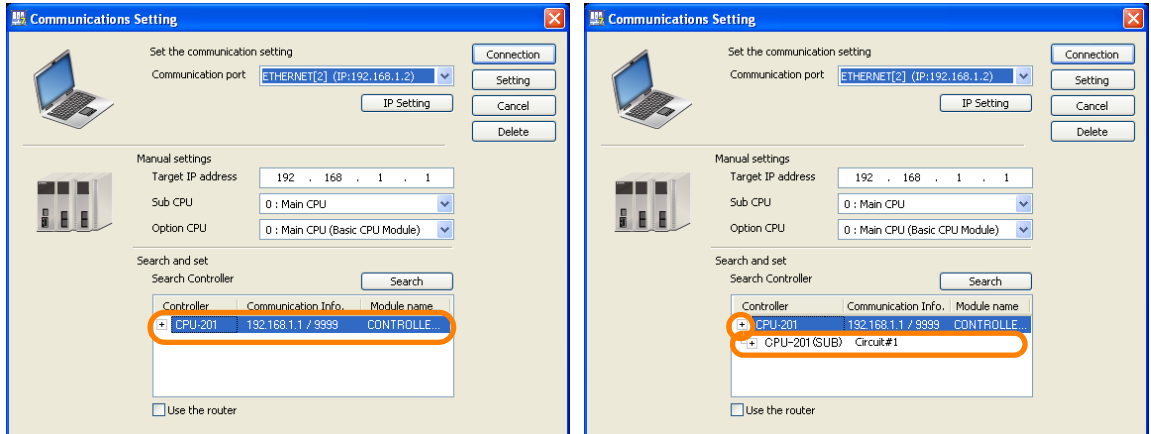

- Click the **Connection** Button.

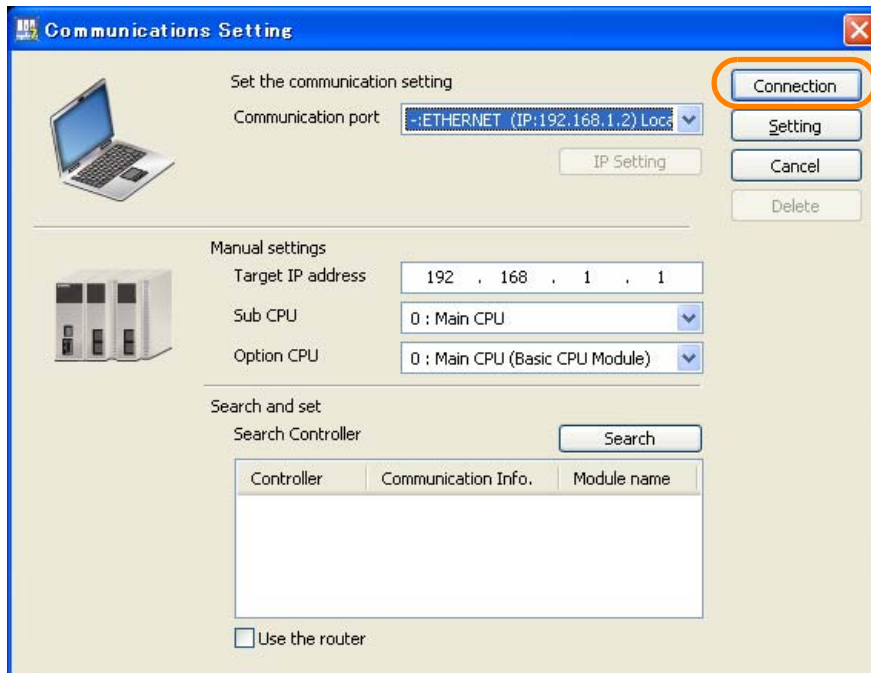

The MPE720 Ver. 7 Window will appear.

9. Confirm that Online appears to the upper left of the Launcher.

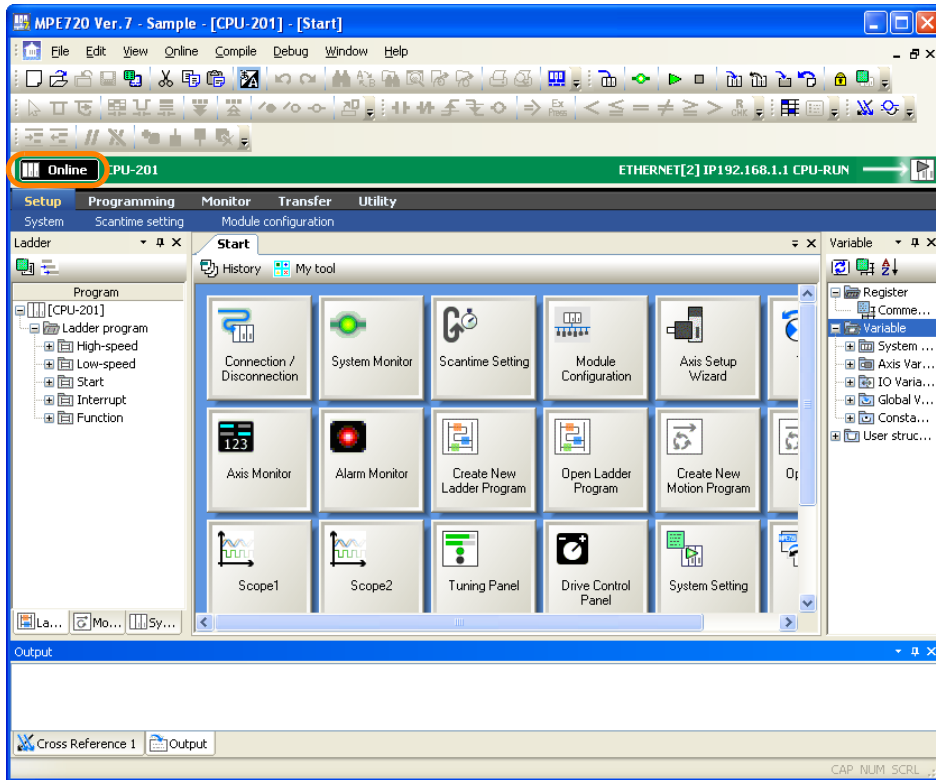

This concludes the settings.

3.6 Device-specific Settings

This section describes the data that is automatically updated during self configuration, and the data that is changed by the user.

3.6.1 Data That Is Automatically Updated during Self Configuration

Use the following procedure to confirm the results of self configuration to make sure that the Modules are properly assigned to the slots.

1. Open the project file.
2. Click the **Module Configuration** Button on the My Tool View.

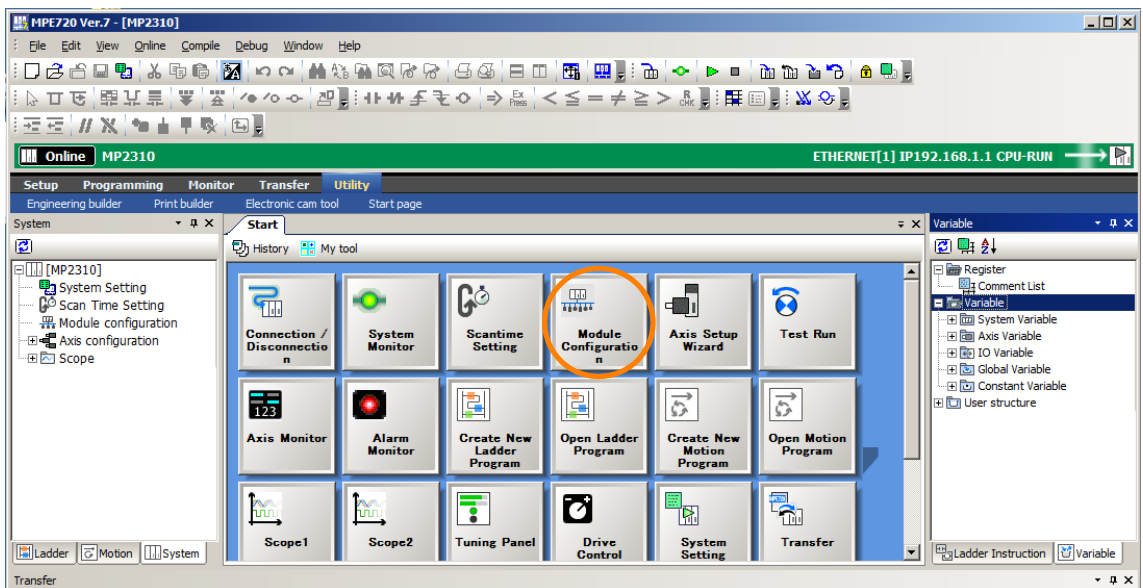

The Module Configuration Tab Page will be displayed as shown below.

The screenshot shows the MC-Configurator software interface. The 'Module Configuration' tab is active, displaying a table of module details. The table has columns for Module, Function Module/Slave, Status, Circuit No./AxisAddress, Motion Register, Register(Input/Output), Disabled, Start - End, Size, Scan, and Comment. The table lists several modules, including CPU, 218FA, SVB, and SVR, along with their respective parameters and addresses.

Module	Function Module/Slave	Status	Circuit No./AxisAddress		Motion Register	Register(Input/Output)	Disabled	Start - End	Size	Scan	Comment
			Start	Occupied circuits							
01 MP2310 :--	01 CPU	Driving	---	---	---	---	---	---	---	---	---
00 MP2310[Driving]	02 218FA	Driving	Circuit No1	1	---	Input 0000 - 07FF[H]	---	2048	---	---	---
	03 SVB	Driving	Circuit No1	1	8000 - 87FF[H]	Input 0800 - 0BFF[H]	---	1024	---	---	---
	04 SVR	Driving	Circuit No2	1	8800 - 8FFF[H]	Output	---	---	---	---	---
	05 -- UNDEFINED --	---	---	---	---	---	---	---	---	---	---
01 -- UNDEFINED --	---	---	---	---	---	---	---	---	---	---	---
02 -- UNDEFINED --	---	---	---	---	---	---	---	---	---	---	---
03 -- UNDEFINED --	---	---	---	---	---	---	---	---	---	---	---

Module Configuration Tab Page Details

The following table describes the items that are displayed in the Module Configuration Tab Page.

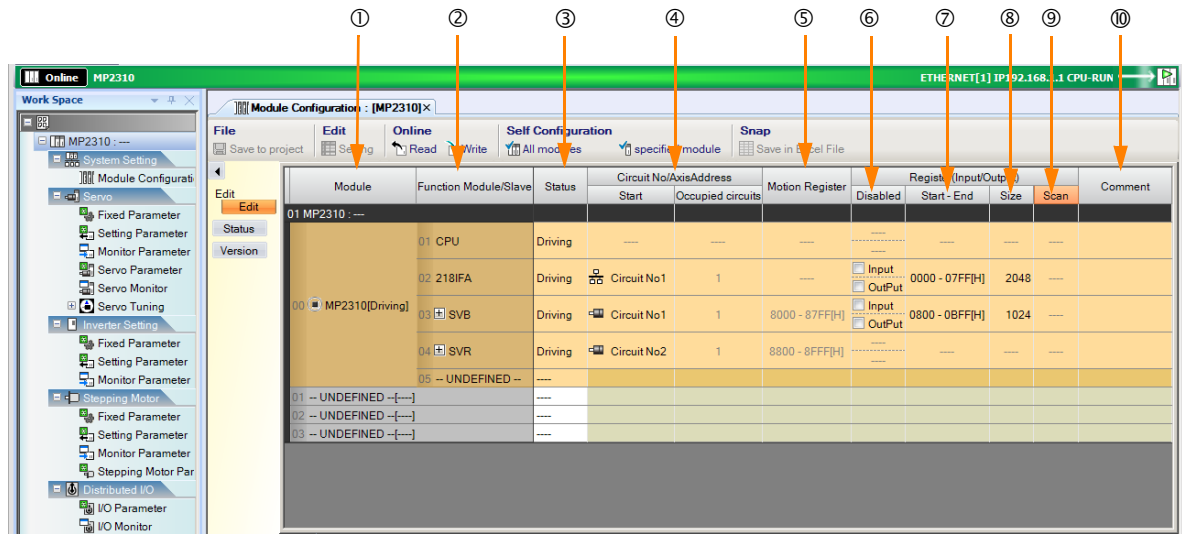

No.	Item	Display/Setting Item	Setting Range/Settings	Editing	
①	Module	Displays the Module that is set for the slot.	Any Module	Possible	
②	Function Module/ Slave	Displays the Function Modules and slaves that are used by the Module.	Any Function Module or slave	Possible	
③	Status	In Online Mode, displays the status of the Function Modules and the communications status of MECHATROLINK slave devices.	Refer to the following section. ◆ <i>Status Display Contents</i> on page 3-31	Not possible	
④	Circuit No./Axis Address	Start	Displays the first circuit number that is assigned to the Module.	Circuit No. 1 to 16	Possible
		Occupied circuits	Displays the number of circuits that are assigned to the Module.	1 to 2	Possible
⑤	Motion Register	Displays the first and last register numbers of the motion parameters.	The parameter is automatically set based on the circuit numbers.	Not possible	
⑥	Disabled	Used to disable inputs or outputs by selecting the check boxes.	Selected or not selected	Possible	
⑦	Register (Input/ Output)	Start - End	Displays the range of registers that is used as an I/O area by the Function Module. For the SVB/SVC, the first and last registers of the I/O Modules that are connected to MECHATROLINK are displayed.	Start: 0000 to 400 hex words max. per SVB/SVC module.*	Possible
⑧	Size	Displays the number of words in the I/O area.	The size depends on the function of the Module.	Possible	
⑨	Scan	Displays the scan in which the I/O service is performed for the I/O device.	High or Low	Possible	
⑩	Comment	Displays the user comment.	You can enter up to 16 characters for a Function Module. You can enter up to 32 characters for a MECHATROLINK slave.	Possible	

* Set I/O registers so that the same registers are not used by more than one Function Module.

Note: Precautions When Setting the Parameters

- Always save all settings to the flash memory after changing them.
- When changing the settings, be careful not to set register numbers that overlap with other Modules.
- Set I/O start and end registers even if a I/O Module is not connected to the MECHATROLINK network.

◆ Status Display Contents

The following status is displayed for Function Modules.

Display	Description
----	The Function Module is not defined.
Empty	The Function Module is defined, but it is not operating correctly.
Driving	The Function Module is operating normally.
Failure	An error was detected in the Function Module.
×	A Function Module is operating, but it is not the Function Module that was defined.
Initializing	The Function Module is defined, but there is no Detailed Function Module Definition.
Driving Stop	The CPU Module is stopped (The user programs are stopped).

3.6.2 Detailed Module Settings

Use the following settings as required.

- MECHATROLINK communications settings
- Motion control settings
- Communications settings

Refer to the following manual for details on communications settings.

📖 Machine Controller MP2300S/MP2310/MP2400 Basic Module Supplement for Ethernet Communications (Manual No.: SIEP C880700 37)

MECHATROLINK Communications Settings

This section describes settings relating to the built-in SVB feature.

Refer to the following manual for details.

📖 Machine Controller MP2000 Series Built-in SVB/SVB-01 Motion Module USER'S MANUAL (Manual No.: SIEP C880700 33)

Double-click **SVB** at slot 3 to display the MECHATROLINK Communications Definition Dialog Box.

The MECHATROLINK Communications Definition Dialog Box has three tabs: Transmission Parameters, I/O Map, and Status. Click a tab to view the tab page.

◆ Transmission Parameters Tab Page

This tab page displays the parameters required to use the MECHATROLINK communications system.

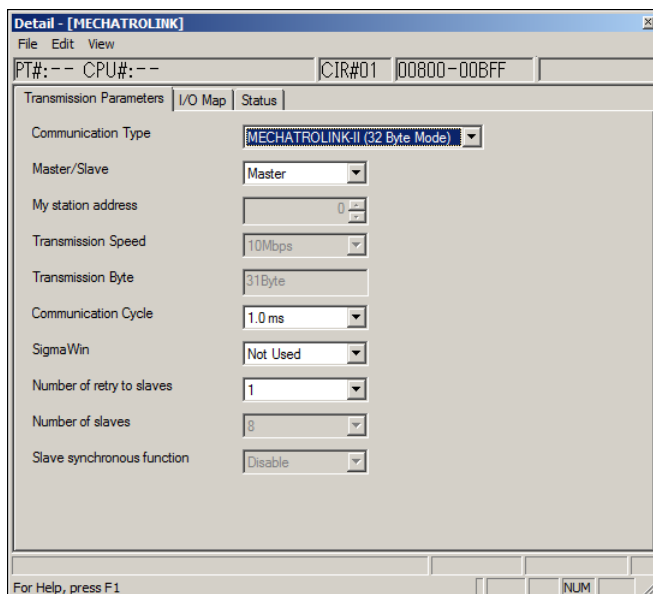

Note: For editable items, the settings can be changed. Always save all settings to the flash memory after changing them.

The items on the Transmission Parameters Tab Page are described in the following table.

Item	Description	Precautions and Settings
Communication Type	Displays the detected communication method.	Select <i>MECHATROLINK-II (32 Byte Mode)</i> , or <i>MECHATROLINK-II (17 Byte Mode)</i> .
Master/Slave	Displays whether the selected SVB Module is used as a Master station or Slave station.	Select either <i>Master</i> or <i>Slave</i> . A built-in SVB (slot number 00) is fixed to <i>Master</i> .
My station address (Local station address)	Displays the local station address set by using the rotary switches.	For Master station, fixed to 0. For slave stations, set a number between 1 and the number of slave stations.
Transmission Speed	Displays the transmission speed: MECHATROLINK-II (32-byte mode): 10 Mbps MECHATROLINK-II (17-byte mode): 10 Mbps	Cannot be set.
Transmission Bytes	Displays the number of transmission bytes. The number of transmission bytes depends on the communication type and the station type, Master or Slave.	Cannot be set.
Communication Cycle	Displays the communication cycle. The number of transmission bytes depends on the communication type and the station type, Master or Slave.	Can be set only for the Master station and when MECHATROLINK-II is selected as the communication type. The value that can be set differs depending on whether the SVB Module is a built-in SVB Module or optional SVB Module.
SigmaWin	For MECHATROLINK-II communications, displays whether or not to use SigmaWin+ for communication via MECHATROLINK-II adapter such as JUSP-NP115.	Select either use or not use.
Number of Retries Slaves	Displays the maximum number of slave stations to which the Master can retry transmission in one transmission cycle when the Master has not received a normal response from a slave.	Only for Master station. Set a number between 0 and 7. Cannot set for Slaves.
Number of Slaves	Displays the number of slave stations that can be connected. Determined by communication type, communication cycle, use of SigmaWin+, and number of attempts to retry transmission to slaves.	Cannot be set.
Wait for Monitor Data Update (Hidden for built-in SVB Modules)	Displays whether or not to suspend CPU processing for the scan delay time of monitoring parameters of an optional SVB Module. Suspended when enabled, not suspended when disabled.	Select either Enable or Disable.

Information

Slave Synchronization Settings (Slave CPU Synchronization)

Slave CPU synchronization is used for configurations with one SVB or SVC (MECHATROLINK master) and more than one SVB or SVC (MECHATROLINK slaves) to synchronize the high-speed scan cycle of the Machine Controller with the master SVB with the high-speed scan cycles of the Machine Controllers with the slave SVBs. This enables synchronization between slave CPU Modules, so if more than one SVB or SVC are connected as slaves, the application programming can be distributed. The following schematic diagram illustrates the synchronization of slave CPU Modules using SVBs.

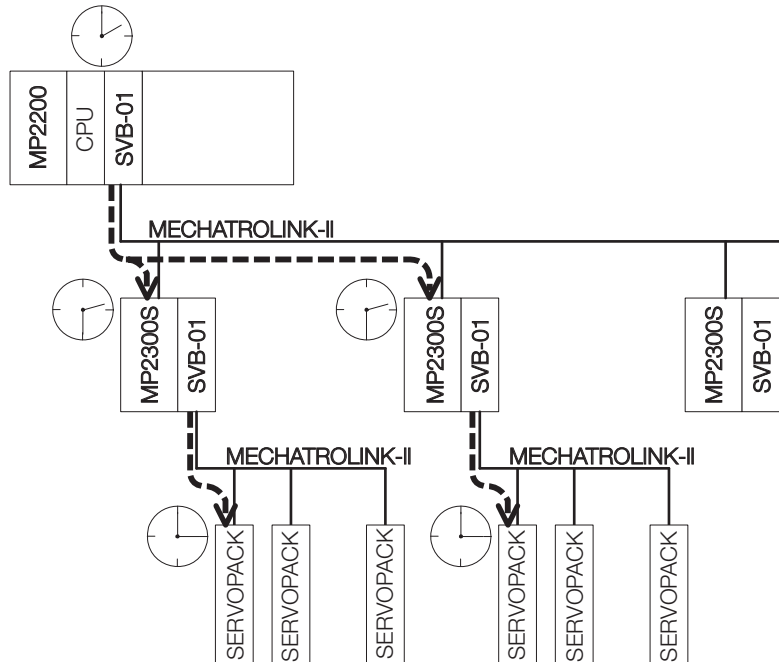

This diagram shows that the MECHATROLINK-II communications are delayed until the application programming in the master sends references to the slaves. The delay time is constant, so the application programming can manage the timing between the master and the slaves. There is no need to manage the timing between the slave CPU Modules, because their timing is synchronized with no delay. Refer to the manuals of the Machine Controller for details.

◆ I/O Map Tab Page

This tab page allows you to check the assignment settings of I/O registers.

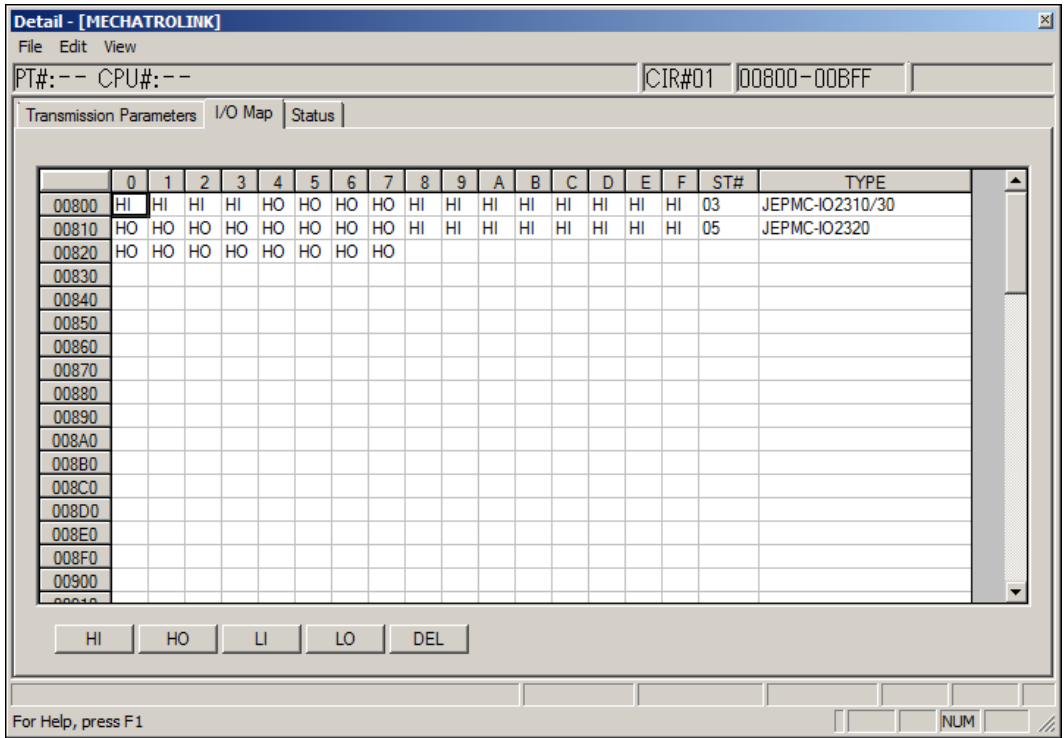

◆ Status Tab Page

This tab page allows you to check the assignment settings for all slave devices that were detected during self-configuration (MECHATROLINK-connected devices, such as SERVO-PACKs or distributed I/O).

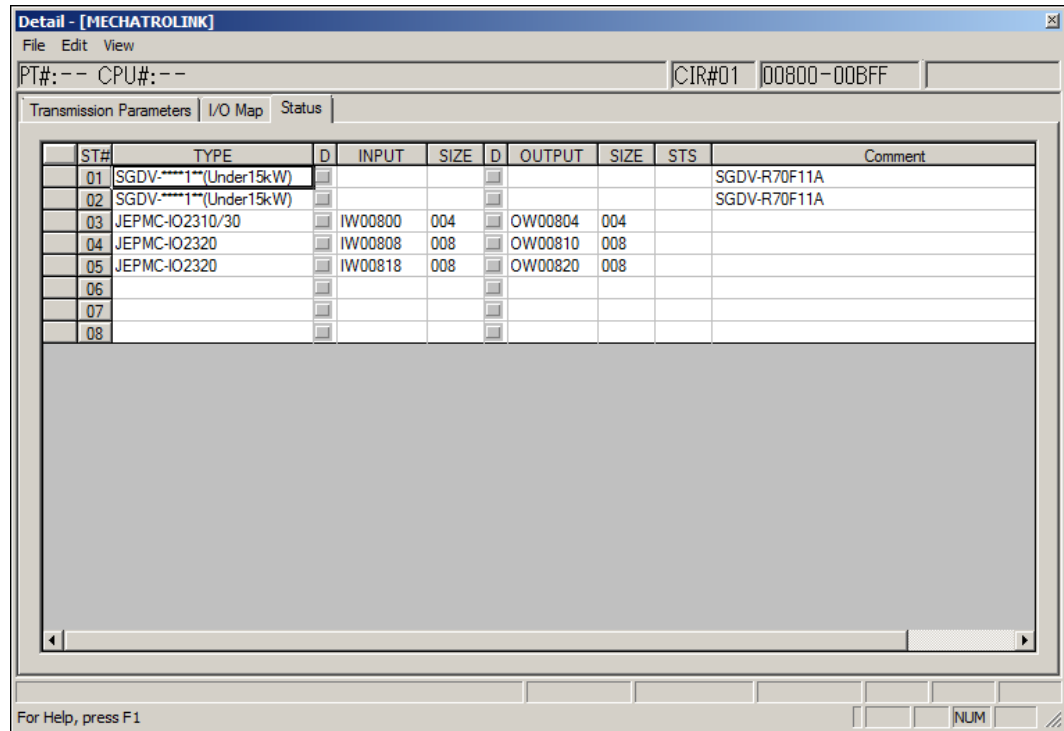

Motion Control Settings

Refer to the following manuals for details on motion control settings.

Machine Controller MP2000 Series Built-in SVB/SVB-01 Motion Module USER'S MANUAL (Manual No.: SIEP C880700 33)

Machine Controller MP2000 Series SVC-01 Motion Module USER'S MANUAL (Manual No.: SIEP C880700 41)

Use the following procedure to display the SVB Definition Tab Page.

1. Select **View – Work Space** from the menu bar.

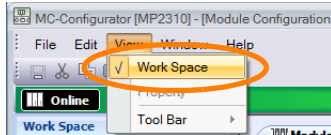

The Work Space Pane is displayed on the left side of the window.

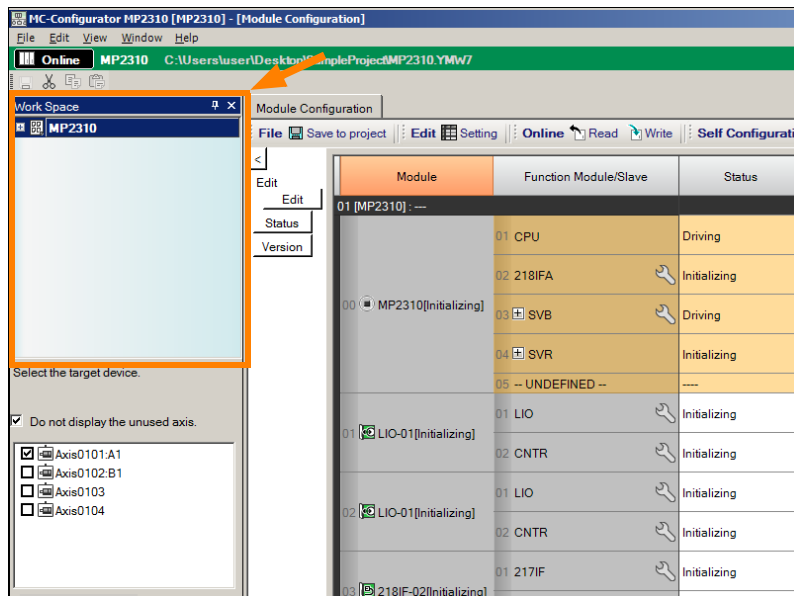

2. Click the **Expand [+]** Button beside each item in the Work Space Pane to display motion parameters as shown below.

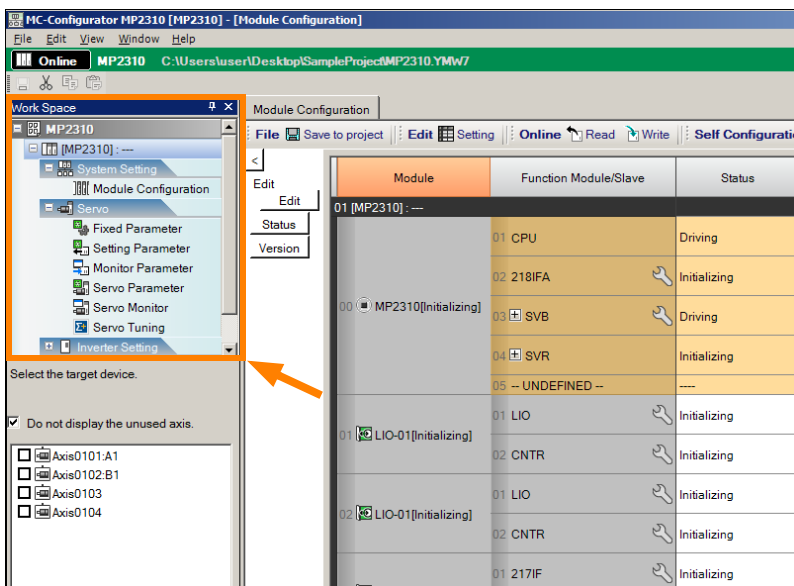

3. Select the axis to set or monitor, and then double-click the motion parameter to set or monitor.

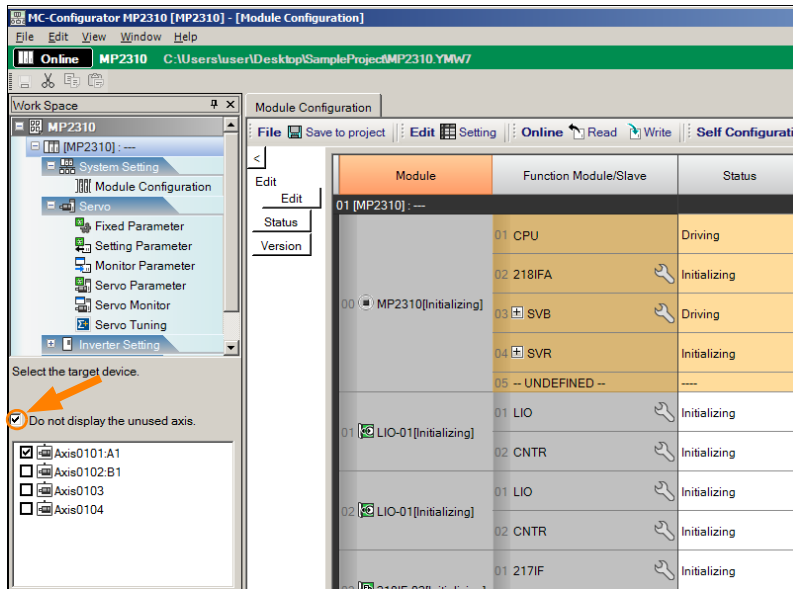

The SVB Definition Tab Page for the selected motion parameters will be displayed.

Information To change which motion parameters are displayed, double-click the required motion parameters in the Work Space Pane.

◆ Setting the Fixed Parameters

The values of the fixed parameters depend on the Servomotor that is controlled by the Controller, and also on the machine that is driven by the Servomotor. These settings cannot be changed from a ladder program.

The actual values to set will depend on the Servomotor and the machine.

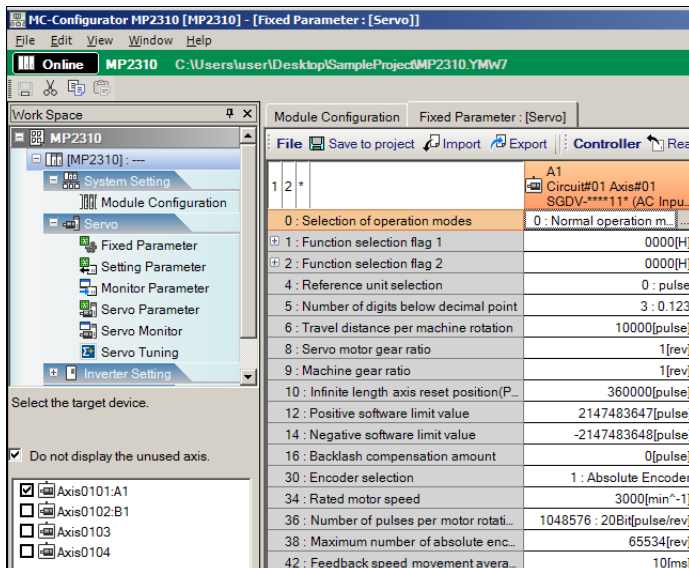

◆ Setting the Setting Parameters

The values of these parameters are normally set from a ladder program. However, values for setting parameters that do not need to be set from a ladder program can be specified on this tab page and saved from here. These values will be used when the system is started.

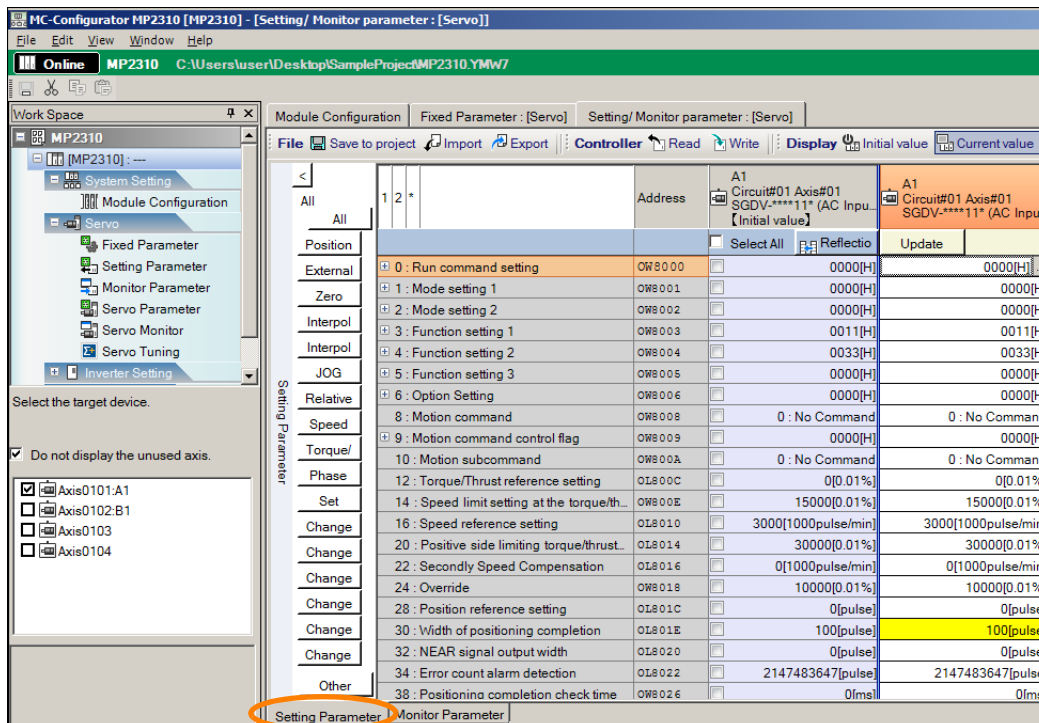

◆ Viewing the Motion Monitor Parameters

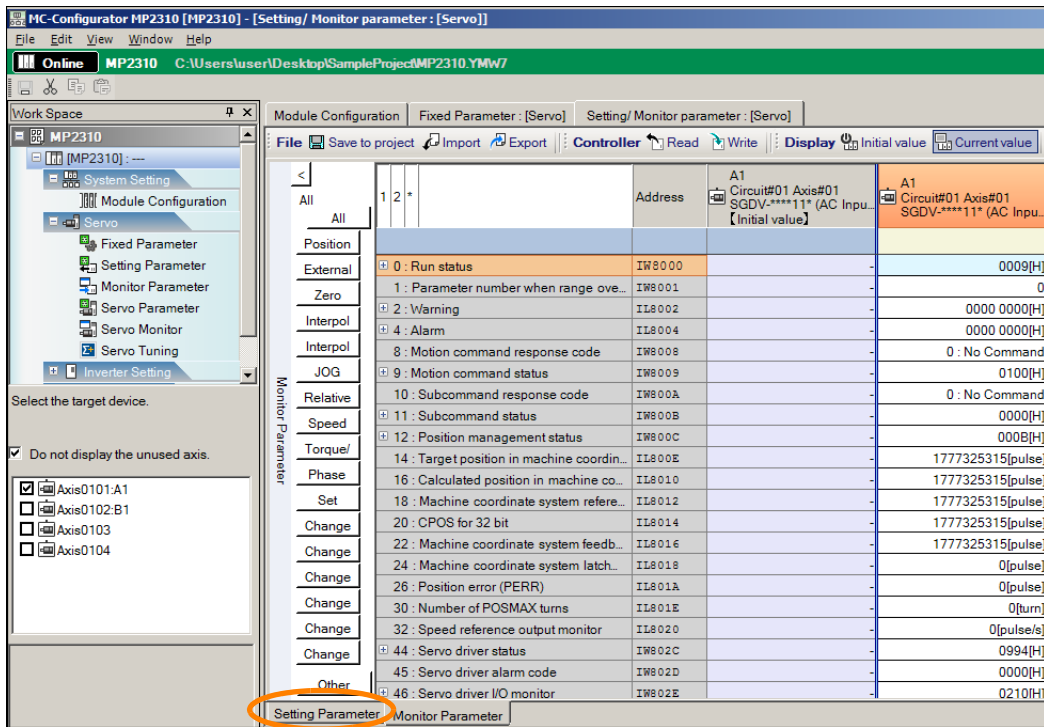

◆ Setting the SERVOPACK Parameters

The settings of the parameters can be prepared inside the CPU Unit of the Controller while it is offline. When the Controller and the SERVOPACK are connected, you can transfer these values to the SERVOPACK in one batch.



Important

- The default settings are used without any changes.
- Never modify the values of parameters that are given as reserved parameters.

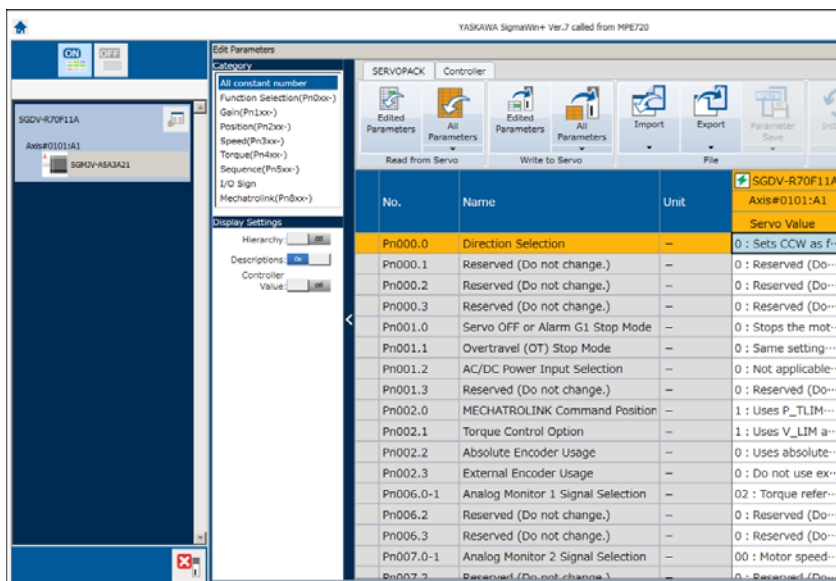

◆ Viewing the SERVOPACK Monitor Information

YASKAWA SigmaWin+ Ver.7 called from MPE720

SGDV-R70F11A

Axis#0101:A1

POWER

HBB P-OT

N-OT

Monitor

Operation

Control	I/F	Item	Unit	Value
	✓	✓		SGDV-R70 Axis#01
POS SPD TRQ	Common	Motor rotating speed	min-1	0
POS SPD TRQ	Common	Input reference pulse speed	min-1	0
POS SPD TRQ	Common	Position error amount	reference ur	0
POS SPD TRQ	Common	Current Alarm State	-	Normal

Status I/O

Status

Control	I/F	Item	Value	Value
	✓	✓		SGDV-R70 Axis#01
POS SPD TRQ	Common	Main Circuit	ON(ALL)	ON
POS SPD TRQ	Common	Encoder (PGRDY)	ON(ALL)	ON
POS SPD TRQ	Common	Motor Power (Request)	-	OFF
POS SPD TRQ	Common	Dynamic Brake (DB)	ON(ALL)	ON
POS SPD TRQ	Common	Rotation Direction	-	OFF
POS SPD	Common	Mode Switch	-	OFF
POS	Common	Position Reference (PULS)	-	OFF
POS SPD TRQ	Common	AC Power ON	ON(ALL)	ON

Filter Hide Standard Clear

3.6.3 Parameters Updated during Self Configuration

The fixed values in the Machine Controller are written to the SERVOPACK EEPROM or RAM during self-configuration as shown below. The SERVOPACK parameters are also written to the Machine Controller's setting parameters.



SERVOPACK parameters and Machine Controller parameters may be overwritten when self configuration is executed.

Writing Parameters to the SERVOPACK

The following settings are written regardless of the setting of bit A (SERVOPACK Parameter Auto-Write) in fixed parameter No. 1.

<MP2000-series Machine Controller>		<SERVOPACK>	
Fixed Values		Servo Parameters	
Name	Set Value	No.	Description
P-OT Signal Mapping	Disable	→ Pn50A n.7□□□	Forward Drive Prohibit signal is always enabled.
N-OT Signal Mapping	Disable	→ Pn50B n.□□□7	Reverse Drive Prohibit signal is always enabled.
Positive Servo Software Limit	Disable	→ Pn801 n.□□□3	Disable both forward and reverse software limits.
Negative Servo Software Limit	Disable	→ Pn20E	The setting will be 1.
Servo Electronic Gear Ratio Numerator	1	→ Pn210	The setting will be 1.
Servo Electronic Gear Ratio Denominator	1	→ -	-
Autotuning Application Selections	Disable	→ -	-
/DEC Signal Mapping	CN1-9	→ Pn511 n.□□□3	Active when CN1-9 input signal is ON (closed).
/EXT1 Signal Mapping	CN1-10	→ Pn511 n.□□4□	Active when CN1-10 input signal is ON (closed).
/EXT2 Signal Mapping	CN1-11	→ Pn511 n.□5□□	Active when CN1-11 input signal is ON (closed).
/EXT3 Signal Mapping	CN1-12	→ Pn511 n.6□□□	Active when CN1-12 input signal is ON (closed).
Velocity Control Option	Use T-REF as the external torque limit input.	→ Pn002 n.□□□1	Use P_TLIM or N_TLIM as the torque limit.
Torque Control Option	Use V-REF as the external speed limit input.	→ Pn002 n.□□1□	Use the speed limit for torque control (VLIM) as the speed limit.
Forward Latching Allowable Area	Setting of Pn820	→ Pn822	The setting will be the value of Pn822 (Reverse Latching Allowable Area).
Command Data Allocation	1	→ Pn81F n.□□1□	Position control command TFF/TLIM allocation is enabled.
Linear Accel/Decel Constant Selection	1	→ Pn833 n.□□□1	Use Pn834 to Pn83E.
Position Error Overflow Range	65535	→ -	-
Overflow Level	32767	→ -	-
Excessive Position Error Alarm Level	2 ³⁰ -1	→ Pn520	The setting will be 2 ³⁰ -1.
Excessive Position Error Warning Level	100	→ Pn51E	The setting will be 100.

Information Parameters are not written to the SERVOPACK when the axis has been set previously.

Writing Parameters to the Machine Controller

The following settings are written when bit A (SERVOPACK Parameter Auto-Write) in fixed parameter No. 1 is set to 0 (Enable).

<MP2000-series Machine Controller>			<SERVOPACK>	
Parameter			Servo Parameters	
No.	Name		No.	Description
Rotary	–	Motor Type*	←	According to the Servomotor that is connected.
	30	Encoder Selection	←	
	34	Rated Motor Speed	←	
	36	Number of Pulses per Motor Rotation	←	
	38	Maximum Number of Absolute Encoder Rotations	←	
Linear	–	Motor Type*	←	According to the Servomotor that is connected.
	6	Linear Scale Pitch	←	
	30	Encoder Selection	←	
	34	Rated Speed	←	
	36	Number of Pulses per Linear Scale Pitch	←	
			Pn205	Multiturn Limit Setting

* The motor type is written to the **Motor Type** Box at the upper right of the **SVB Definitions** Dialog Box.

Parameter			Servo Parameters		
No.	Name		No.	Description	
OW□□□2E	Position Loop Gain		←	Pn102	Position Loop Gain
OW□□□2F	Speed Loop Gain		←	Pn100	Speed Loop Gain
OW□□□30	Speed Feedforward Compensation		←	Pn109	Feedforward
OW□□□32	Position Loop Integral Time Constant		←	Pn11F	Position Integral Time Constant
OW□□□34	Speed Loop Integration Time Constant		←	Pn101	Speed Loop Integral Time Constant
OW□□□3A	Filter Time Constant		←	Pn812	Movement Average Time

- Information**
- Axes that were previously set in the Module configuration settings will not be changed.
 - The default settings will be written for all other parameters.

3.6.4 Setting Machine-specific Motion Parameters

Set the following eight motion parameters according to the machine’s specifications to ensure correct motion control.

- Reference Unit
- Electronic Gear
- Axis Selection
- Position Reference
- Speed Reference
- Acceleration/Deceleration Settings
- Acceleration/Deceleration Filter Settings
- Linear Scale Pitch/Rated Speed (when using a linear motor)

The following section describes how to use the Axis Setup Wizard to set these parameters.

Axis Setup Wizard

This wizard makes it easy to set up SERVOPACKs that are connected via a MECHATROLINK network.

It provides an easy solution to set up the axes, including setting the SERVOPACK parameters, tuning, setting the Machine Controller according to the machine’s specifications, and backing up data.

Information

The following conditions must be met to use the Axis Setup Wizard.

- Ethernet must be used for the communications port.
- The Machine Controller must be online.
- The MECHATROLINK SERVOPACKs must be in the Σ -V or Σ -7 Series.
- SigmaWin+ version 5.11 or later must be installed.

If SigmaWin+ version 5.11 or later is not installed, it can be downloaded for free from the Internet (product and technical information website).

Use the following URL: <http://www.e-mechatronics.com/support/tool/> (Japanese only)

Starting the Axis Setup Wizard

To start the Axis Setup Wizard, double-click **Axis Setup Wizard** under **Axis configuration** in the System Pane.

Alternatively, you can click the **Axis Setup Wizard** Button on the Start Tab Page.

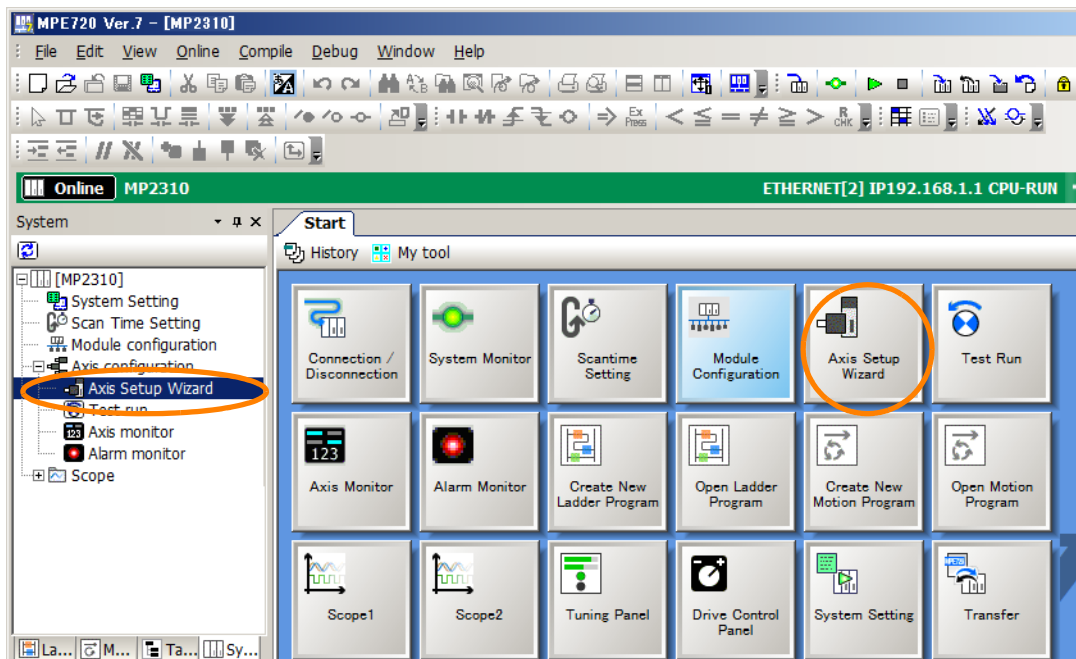

Axis Setup Wizard Details

◆ Axis Setup Wizard

This wizard sets up individual axes for SERVOPACKs that are connected to a MECHATROLINK network.

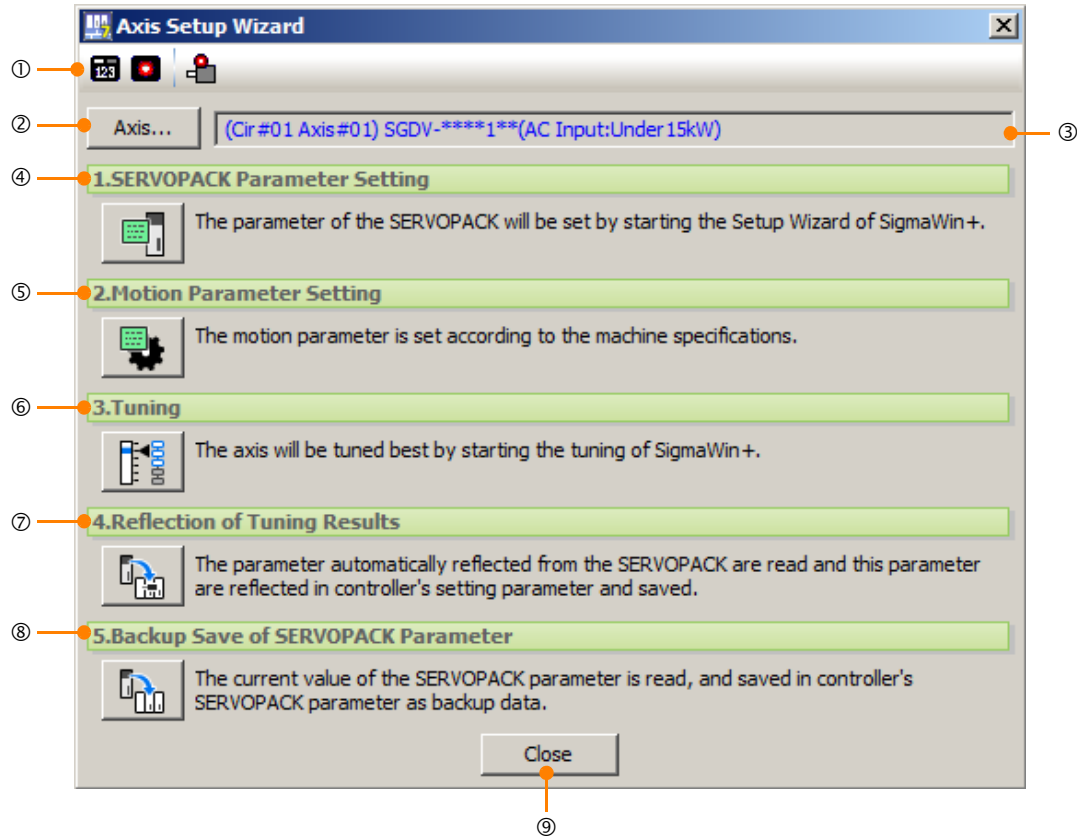

No.	Item	Description
①	Axis Monitor	Displays the Axis Monitor Dialog Box.
	Alarm Monitor	Displays the Alarm Monitor Dialog Box.
	Alarms/Warnings	Displays the Alarms/Warnings Dialog Box.
②	Axis Selection	Displays the Axis Selection Dialog Box to select the axis to set up.
③	Axis Display	Displays the selected axis.
④	SERVOPACK Parameter Setting	Starts the SigmaWin+ Setup Wizard to set the SERVOPACK parameters.
⑤	Motion Parameter Setting	Displays the Motion Parameter Dialog Box to set the motion parameters according to the machine specifications.
⑥	Tuning	Starts SigmaWin+ tuning to perform optimal tuning for the axis.
⑦	Reflection of Tuning Results	Loads the parameters that are automatically applied from the SERVOPACK, applies them to the setting parameters in the Machine Controller, and then saves them.
⑧	Backup Save of SERVOPACK Parameter	Loads the current values of the SERVOPACK parameters and back them up in the SERVOPACK parameters in the Machine Controller.
⑨	Close	Closes the Axis Setup Wizard Dialog Box.

◆ Axis Selection

The information that is assigned in the Module configuration definition will be displayed. Select the axis to set up.

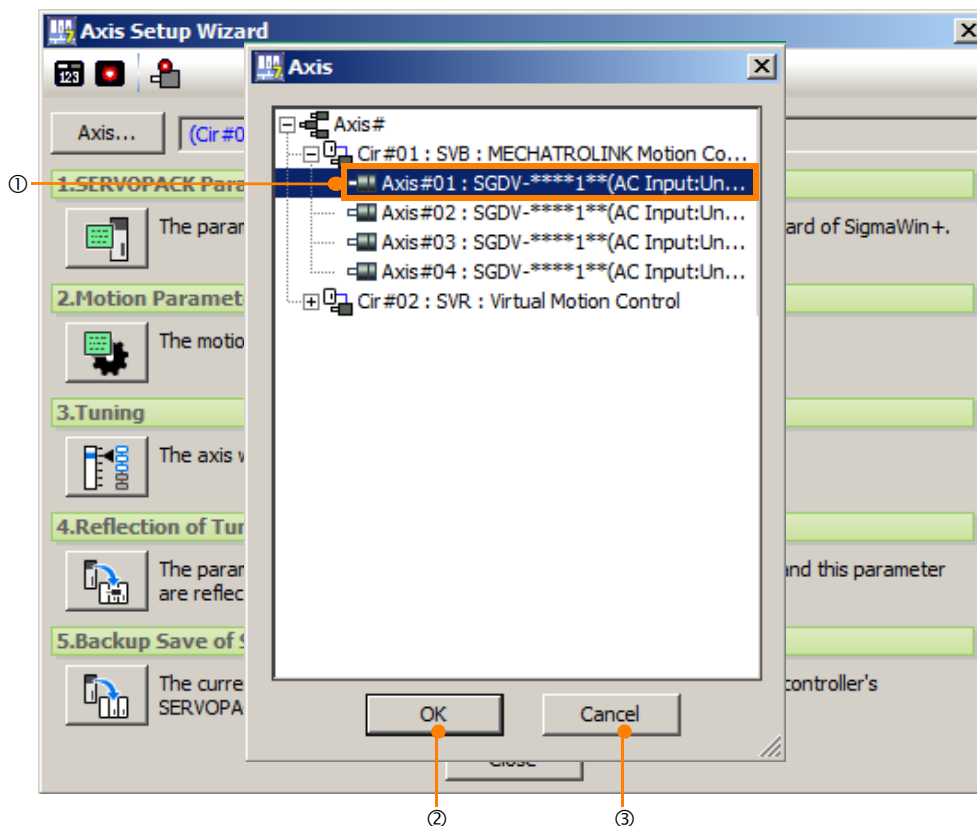

Information Only the selected single axis can be used in the Axis Setup Wizard. To set up other axes, click the Axis... Button and select the axis in the Axis Selection Dialog Box. Repeat this for each axis.

No.	Item	Description
①	Axis	The axis assigned to the module configuration definition is displayed.
②	OK	Selects the axis, and returns the display to the Axis Setup Wizard.
③	Cancel	Cancels selection of the axis, and returns the display to the Axis Setup Wizard.

◆ Motion Parameter Setting

The motion parameters of the Machine Controller are set according to the machine.

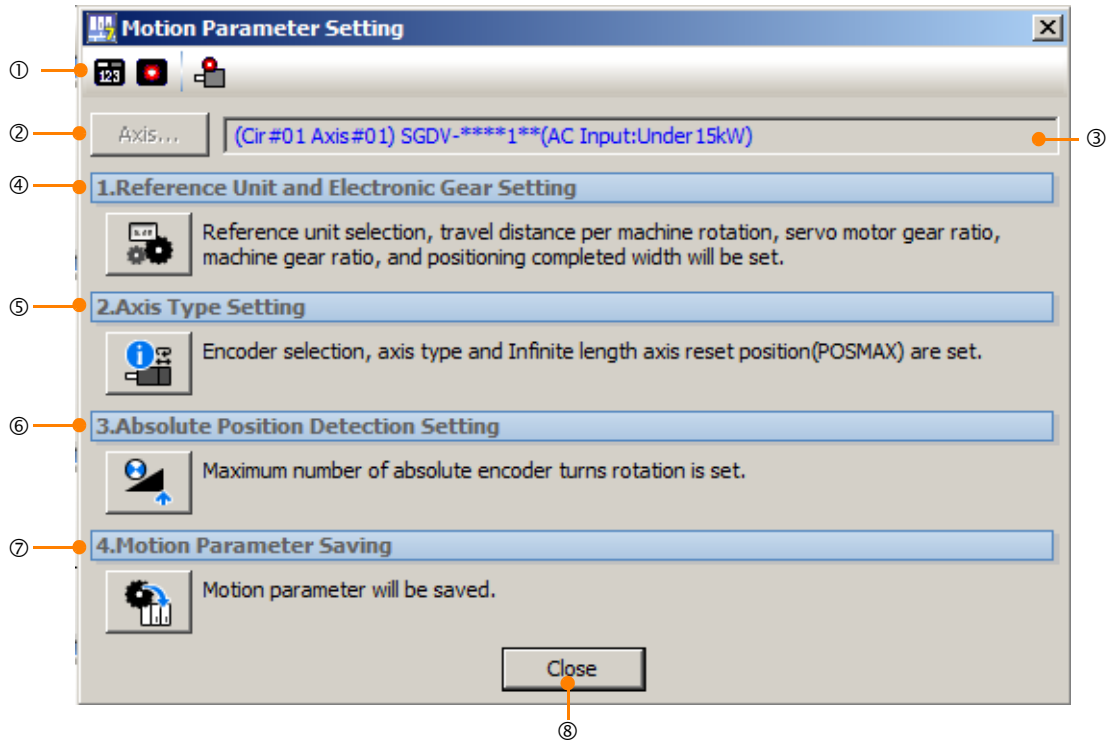

No.	Item	Description
①	Tool Bar	Refer to Tool Bar (1) in the Axis Setup Wizard Dialog Box.
②	Axis...	This button is disabled.
③	Axis Display	Displays the selected axis.
④	Reference Unit and Electronic Gear Setting	Displays the Reference Unit/Electronic Gear Dialog Box to set the reference unit and the electronic gear.
⑤	Axis Type Setting	Displays the Axis Type Setting Dialog Box to set the motor type and the axis type.
⑥	Absolute Position Detection Setting	Displays the Absolute Position Detection Setting Dialog Box to set the simple absolute infinite axis position management and maximum number of absolute encoder rotations.
⑦	Motion Parameter Saving	Displays the Motion Parameter Saving Dialog Box to save the modified values of the motion parameters.
⑧	Close	Closes the Motion Parameter Setting Dialog Box.

■ Reference Unit

The motion control reference unit can be set to the pulse, mm, deg, inch, or μm . The reference unit is specified in motion fixed parameter No. 4 (Reference Unit Selection). The minimum reference unit is determined by the setting of motion fixed parameter No. 5 (Number of Digits Below Decimal Point).

Motion Fixed Parameter No. 5 (Number of Digits Below Decimal Point)	Motion Fixed Parameter No. 4 (Reference Unit Selection)				
	0: pulse	1: mm	2: deg	3: inch	4: μm
0: 0 digits	1 pulse	1 mm	1 deg	1 inch	1 μm
1: 1 digit	1 pulse	0.1 mm	0.1 deg	0.1 inch	0.1 μm
2: 2 digits	1 pulse	0.01 mm	0.01 deg	0.01 inch	0.01 μm
3: 3 digits	1 pulse	0.001 mm	0.001 deg	0.001 inch	0.001 μm
4: 4 digits	1 pulse	0.0001 mm	0.0001 deg	0.0001 inch	0.0001 μm
5: 5 digits	1 pulse	0.00001 mm	0.00001 deg	0.00001 inch	0.00001 μm

} Minimum reference units

■ Electronic Gear

The amount of change in the mechanical system (i.e., the travel distance) for the input of 1 reference unit is called the output unit. The electronic gear converts positions or speeds from reference units to output units for the mechanical system without going through an actual mechanism, such as a gear.

If the mechanical configuration is such that rotating the Servomotor axis m times results in rotating the load axis n times, this electronic gear can be used to make the output units equivalent to the reference units.

The electronic gear function is enabled when the following settings are made:

- Motion fixed parameter No. 6 (Travel Distance per Machine Rotation)
- Motion fixed parameter No. 8 (Servomotor Gear Ratio)
- Motion fixed parameter No. 9 (Machine Gear Ratio)

- Information**
- The electronic gear is disabled when the pulse is specified as the reference unit.
 - Set the SERVOPACK electronic gear ratio to 1:1.

The following examples show the settings for a ball screw and rotary table as loads.

• Ball Screw

Reference Unit/ Electronic Gear

Unit

Reference unit selection : 0 : pulse Speed unit selection : 1 : 10ⁿ reference unit/m

Number of digits below decimal point : 3 : 0.123 Acceleration/Deceleration degree unit selection : 1 : ms

Torque unit selection : 0 : 0.01%

Electronic Gear

Mechanical

Ball Screw (6)

Set the ball screw pitch.

Pitch P = 10000 [pulse] (7)

One pitch is the moving distance per ball screw.

Set the gear ratio.

$$\text{Gear ratio} = \frac{n \text{ (load axis)}}{m \text{ (motor)}} = \frac{1 \text{ [rev]}}{1 \text{ [rev]}}$$
 (8) (9)

When the servomotor rotates m for a load axis rotation of n, the gear ratio is represented by n/m.

Width of Positioning Completion

Set the positioning completed width.

Width of Positioning Completion = 100 [pulse] (10)

If the difference between the command position and the current position (the position deviation) is within this setting range, the "positioning completion signal" (IWxx0C Bit 1) comes ON.

Set (11) Cancel (12)

• Rotary Table

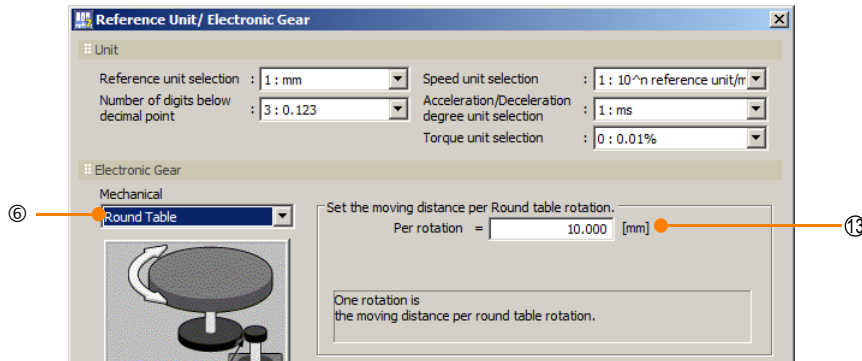

• Belt and Pulley

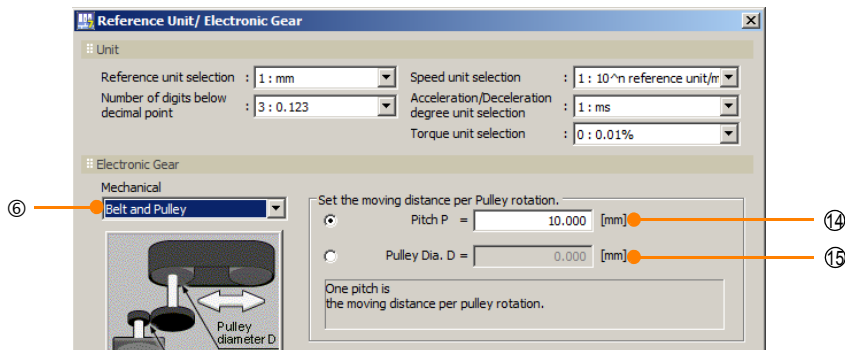

No.	Item	Description
①	Reference unit selection	Select one of the following five reference units. 0: pulse, 1: mm, 2: deg, 3: inch, or 4: μm When the Reference Unit Selection parameter is set to 0 (pulse), the settings from (2) onward are disabled.
②	Number of digits below decimal point	Select the number of decimal digits from the following six settings. 0: None, 1: 0.1, 2: 0.12, 3: 0.123, 4: 0.1234, or 5: 0.12345
③	Speed unit selection	Select the speed unit from the following four settings. 0: reference unit, 1: 10^n reference unit /min, 2: % of the rated speed (1 = 0.01%), 3: % of the rated speed (1 = 0.0001%)
④	Acceleration/Deceleration degree unit selection	Select the acceleration/Deceleration degree unit from the following two settings. 0: reference unit/ s^2 , 1: ms
⑤	Torque unit selection	Select the torque unit from the following two settings. 0: % of the rated torque (1 = 0.01%), 1: % of the rated torque (1 = 0.0001%)
⑥	Mechanical	Select the mechanical configuration from the following three settings. a: Ball Screw b: Rotary Table c: Belt and Pulley
⑦	Pitch P	Set the travel distance per revolution of the ball screw.
⑧	Load axis revolutions	Set the number of load axis revolutions for the gear ratio.
⑨	Servomotor axis revolutions	Set the number of Servomotor axis revolutions for the gear ratio.
⑩	Width of positioning completion	Set the width of positioning completion.
⑪	Set	Click this button to set the reference unit and electronic gear and return to the Motion Parameter Setting Dialog Box.
⑫	Cancel	Click this button to return to the Motion Parameter Setting Dialog Box without setting the reference unit and electronic gear.
⑬	Per rotation	Set the travel distance per revolution of the rotary table.
⑭	Pitch P	Set the travel distance per revolution of the pulley.
⑮	Pulley Diameter	Set the diameter of the pulley.

■ Axis Type Setting

This dialog box is used to set the motor type and the axis type.

There are two types of position control: finite-length axis position control for round-trip operation and other tasks that are performed only within a specified range, and infinite-length axis position control that is used for rotation in one direction only. Infinite-length axis position control can work in one of two ways: It can be used to reset the position data to 0 after one rotation, e.g., for belt conveyors, or to simply rotate in one direction only, without resetting the position after one rotation.

The following parameters can be set after you set the axis type.

No.	Fixed Parameter
No. 1, bit 0	Axis Selection
No.10	Infinite-length Axis Reset Position (POSMAX)
No.30	Encoder Selection

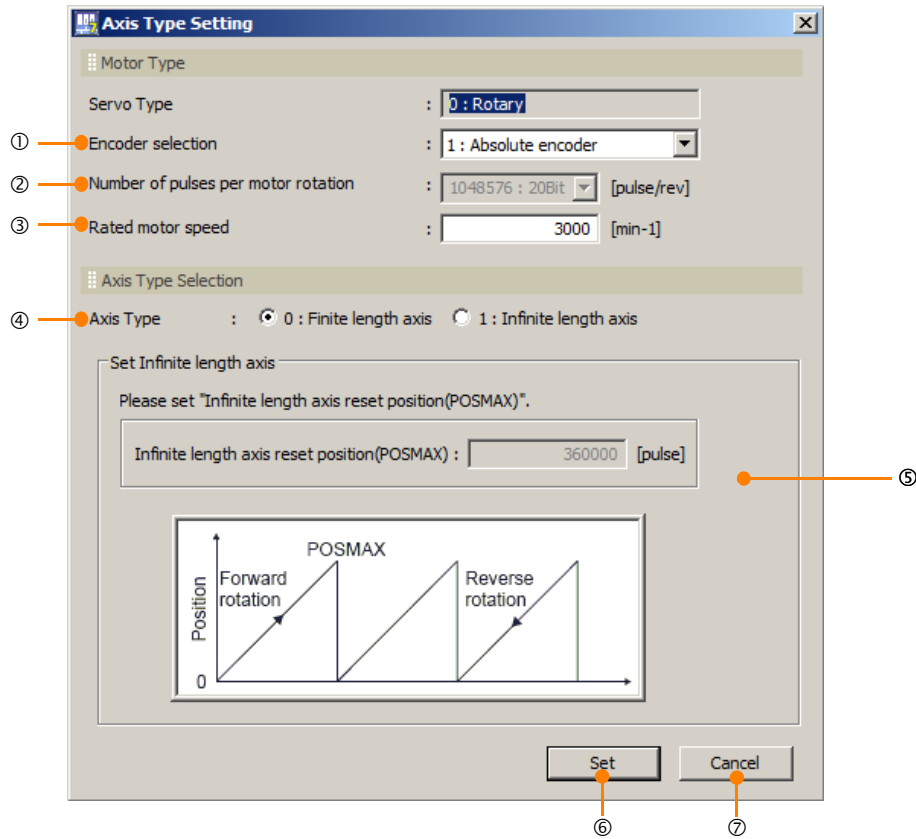

No.	Item	Description
①	Encoder Selection	Select the encoder from the following three settings. 0: Incremental encoder 1: Absolute encoder 2: Absolute encoder (Incremental encoder is used.)
②	Number of pulses per motor rotation	Select the number of pulses per motor rotation from the following ten settings. 1024: 10Bit, 2048: 11Bit, 4096: 12Bi, 8192: 13Bit, 16384: 14Bit, 32768: 15Bit, 65536: 16Bit, 131072: 17Bit, 1048576: 20Bit, 16777216: 24Bit Note: When a servomotor is connected, this is automatically judged and so cannot be selected.
③	Rated motor speed	Set the rated motor speed.
④	Axis Type	Select the axis type from the following two settings. 0: Finite-length axis, 1: Infinite-length axis
⑤	Infinite-length Axis Setting	Set the reset position of the infinite-length axis. This setting is enabled if an infinite-length axis is selected for the axis type (4).
⑥	Set	Click this button to set the axis type and return to the Motion Parameter Setting Dialog Box.
⑦	Cancel	Click this button to return to the Motion Parameter Setting Dialog Box without setting the axis type.

■ Absolute Position Detection Setting

Set the maximum number of absolute encoder rotations for simple absolute infinite axis position management.

The following parameters can be set after you set absolute position detection.

No.	Fixed Parameter
No. 1, bit 9	Simple Absolute Infinite Axis Position Management
No.38	Maximum Number of Absolute Encoder Rotations

Information The values that are set here are also saved in Pn205 (Multiturn Limit Setting).

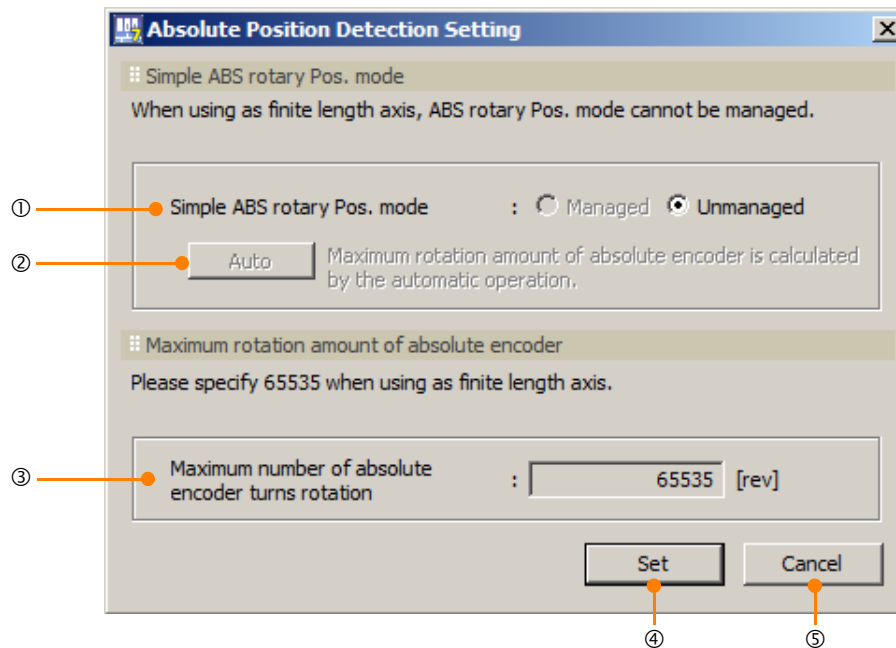

No.	Item	Description
①	Simple Absolute Infinite Axis Position Management	Enable or disable simple absolute infinite axis position management. This selection is enabled if an infinite-length axis is selected for the axis type (4) in the Axis Type Setting Dialog Box.
②	Auto*	Automatically calculates the maximum number of absolute encoder rotations. This button is enabled if the Managed Option was selected at (1).
③	Maximum rotation amount of absolute encoder (Maximum Number of Absolute Encoder Rotations)	Set the maximum number of absolute encoder rotations. If a finite-length axis is selected as the axis type (4) in the Axis Type Setting Dialog Box, then this value can be set to a maximum of 65,535. If an infinite-length axis is selected, the maximum setting will be 65,534.
④	Set	Click this button to set the absolute position detection and return to the Motion Parameter Setting Dialog Box.
⑤	Cancel	Click this button to return to the Motion Parameter Setting Dialog Box without setting the absolute position detection.

* The following formula is used for the automatic calculation:

$$\frac{(\text{Fixed parameter No. 38: Maximum Number of Absolute Encoder Rotations} + 1)}{\text{Reset rotations}} = \text{Integer (Remainder} = 0)$$

The following formulas give the value of the reset rotations. The formula depends on whether the reference unit is set to the pulse or to one of the following: mm, deg, or inch.

• When the Reference Unit Is Pulse

$$\frac{\text{No. 10: Infinite-length Axis Reset Position}}{\text{No. 36: Numbers of Pulses Per Servomotor Rotation}}$$

• When the Reference Unit Is mm, Deg, or Inch

$$\frac{\text{No. 10: Infinite-length Axis Reset Position} \times \text{No. 8: Servomotor Gear Ratio}}{\text{No. 6: Travel Distance per Machine Rotation} \times \text{No. 9: Machine Gear Ratio}}$$

$$\frac{\text{No. 10: Infinite-length Axis Reset Position} \times \text{No. 8: Servomotor Gear Ratio}}{\text{No. 6: Travel Distance per Machine Rotation} \times \text{No. 9: Machine Gear Ratio}}$$

◆ Motion Parameter Saving

This section describes how to save the motion parameter settings.

1. Click the **Axis Setup Wizard Button**, click the **Motion Parameter Setting Button**, and then click the **Motion Parameter Saving Button** to display the following dialog box.

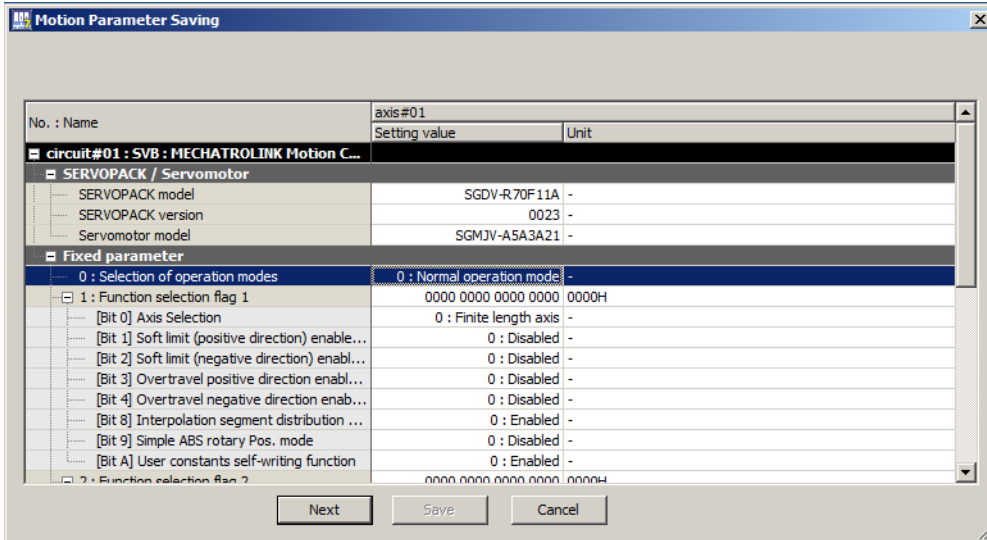

2. Click the **Next Button**. The **Reflect SERVOPACK Parameter Dialog Box** will be displayed. Click the **Check** button to check whether the saved fixed parameters match the SERVOPACK parameter settings.

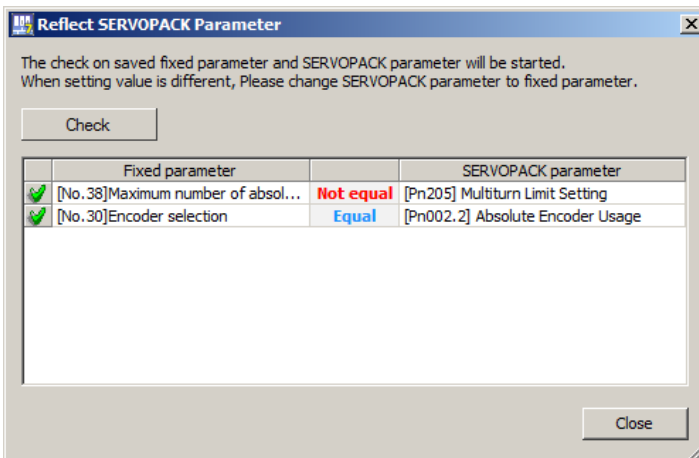

Fixed Parameter	SERVOPACK parameter
No. 38 (Maximum Number of Absolute Encoder Rotations)	Pn205 (Multiturn Limit Setting)
No. 30 (Encoder Selection)	Pn002.2 (Absolute Encoder Usage)

3. Checked parameters will be marked with a green checkmark, and the results of the check will be displayed.

If the fixed parameter and the SERVOPACK parameter match: Equal

If the fixed parameter and the SERVOPACK parameter do not match: Not equal

3.6.5 Calendar Feature

This calendar feature manages date and time. When an alarm occurs, the date and time set by the calendar feature are automatically recorded.

There are two ways of setting the calendar on the Machine Controller.

- Set the time in system registers (SW00015 to SW00019).
Refer to the manual of the Machine Controller to be used for details.
- Use MPE720 to set the time.
The setting procedure is as follows:

1. Click the System Setting Button on the My Tool View.

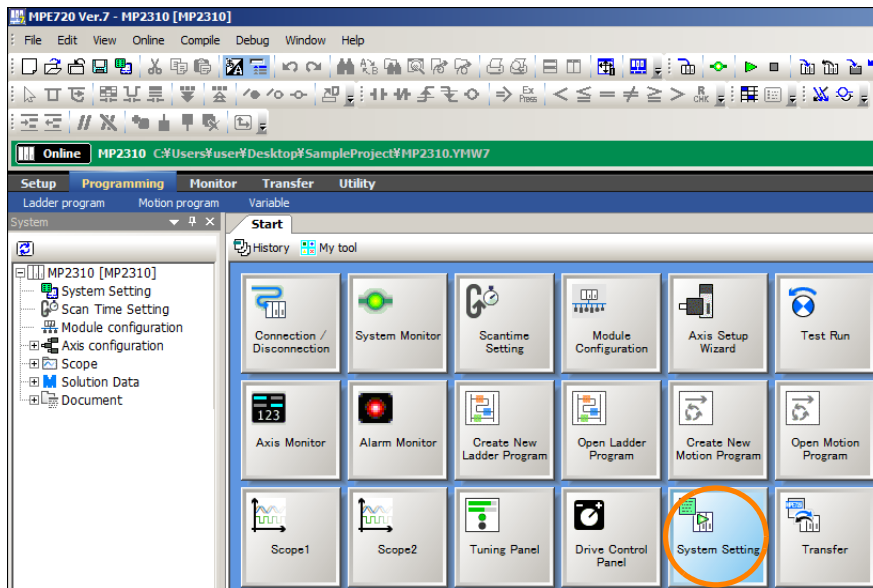

2. Enter the date and time, and click the OK button.

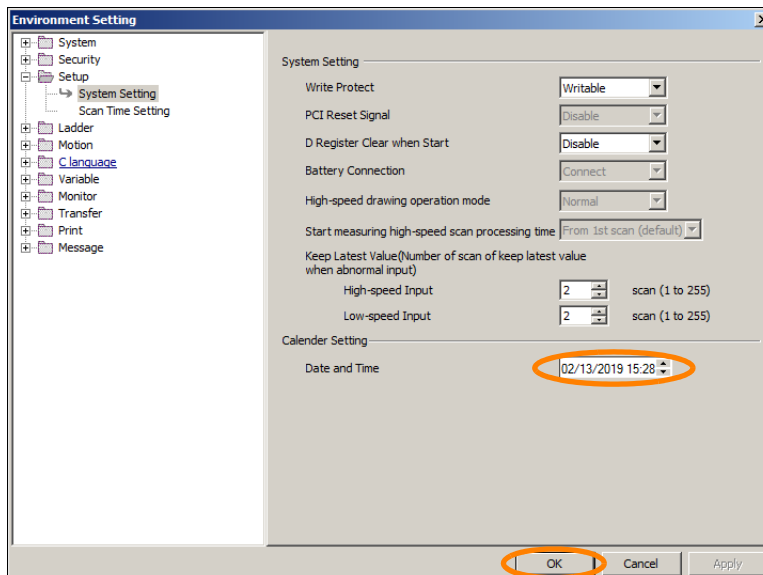

3.6.6 Setting the Scan Times

This section describes how to set the scan times for the high-speed and low-speed scans. Click the **Scan Time Setting** Button on the My Tool View. The following dialog box will be displayed.

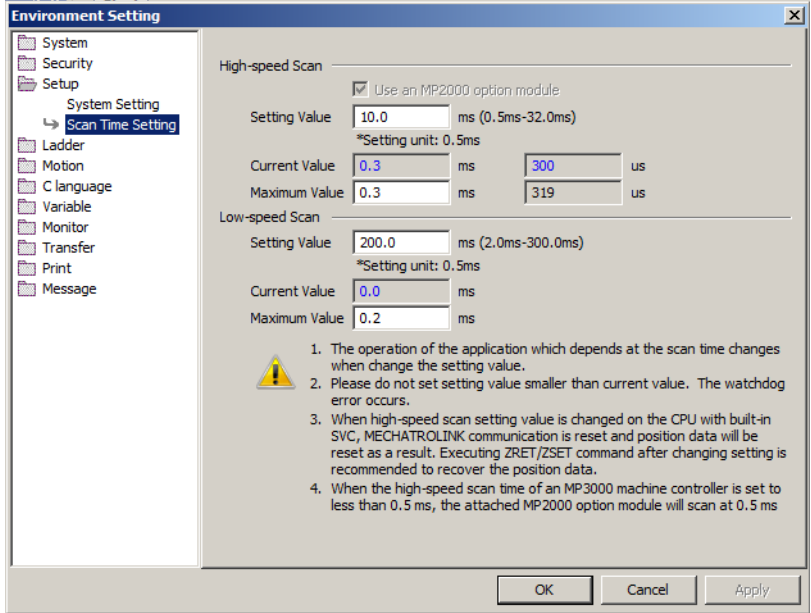

High-speed (H) Scan

This section describes how to set the scan time of a high-speed processing program (H, Hxx, Hxx.xx) in milliseconds.

The set value that is set here will determine the reference pulse distribution cycle (accuracy).

Information The default high-speed scan time is 4.0 ms.

◆ I/O Processing

The following figures show the timing results for these settings.

■ Example: High-speed Scan = 0.5 ms

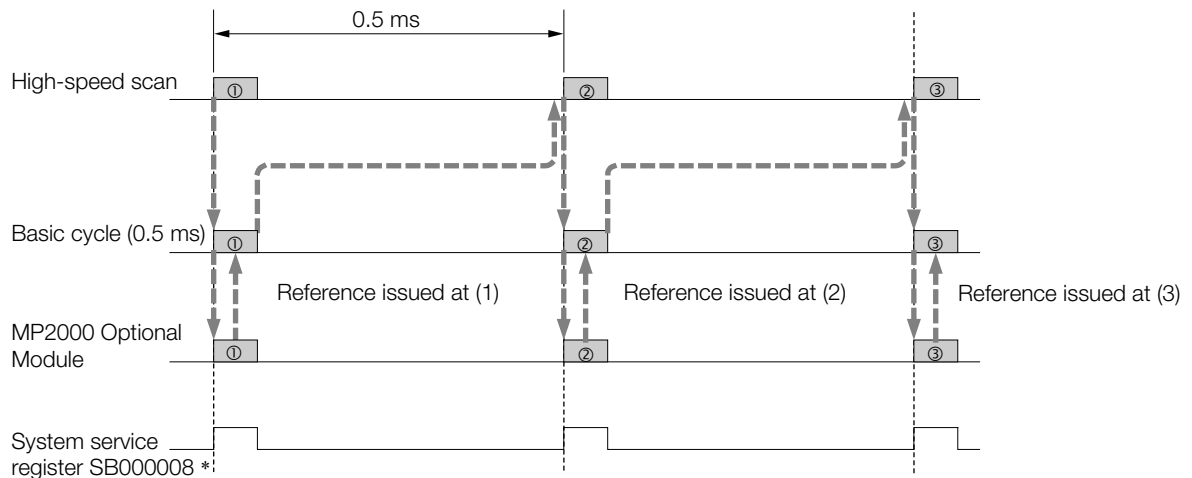

* The purpose of this system service register is to determine from a ladder program whether the MP2000 option service is being scanned.

Low-speed (L) Scan

This section describes how to set the scan time of a low-speed processing program (L, Lxx, Lxx.xx) in milliseconds.

This example shows set values for a control cycle of pushbuttons and similar controls.

The possible set values for the low-speed scan time are 2.0 to 300.0 ms (in 0.5-ms increments).

Information The default low-speed scan time is 200.0 ms.

◆ I/O Processing

During the low-speed scan, the I/O service (I/O processing) is performed every scan, regardless of the set value.

3.7 Test Run

This section describes the features of the test run.

3.7.1 Test Run

The test run checks whether the references issued by the Machine Controller correctly drive the SERVOPACK axis.

You can perform the following operations for a test run from the Test Run Dialog Box.

- **Axis Servo ON and OFF:** You can turn the servo ON and OFF for the specified SERVOPACK axis.
- **Jog:** You can rotate the specified SERVOPACK axis in one direction at a fixed speed.
- **Step:** You can rotate the specified SERVOPACK axis from the current position to the specified position.

There are two ways to monitor the test run.

- **Axis Monitor:** Monitors the operating status of each axis.
- **Alarm Monitor:** You can monitor the alarm information of all axes on one dialog box.



Important

- The test run can be used only if the Motion Module (SVC-01, SVB-01, SVB-01 Inverter, SVA-01, SVR, or PO-01) of the tested axis meets the conditions listed in the following table. If the conditions are not met, you will not be able to perform the test run.

Axis	Motion Operation Ready	Servo Ready	Motion Command Response Code
SVC-01	ON	ON	No Operation
Built-in SVB/SVB-01	Servo	ON	No Operation
	Inverter	–	No Operation
SVA-01	ON	ON	No Operation
SVR	ON	–	No Operation
PO-01	ON	–	No Operation

Note: For an Inverter, use the Operation Enabled bit instead of the Motion Operation Ready bit, and use the Inverter Ready bit instead of the Servo Ready bit.

- Correct operation of the test run requires that no ladder program, motion program, or sequence program is being executed at the same time.

3.7.2 Starting the Test Run and Selecting the Axis

Open the Test Run Dialog Box and specify the SERVOPACK axis to test. Use the following procedure to set the axis.

1. Click the **Test Run** Button on the My Tool View.

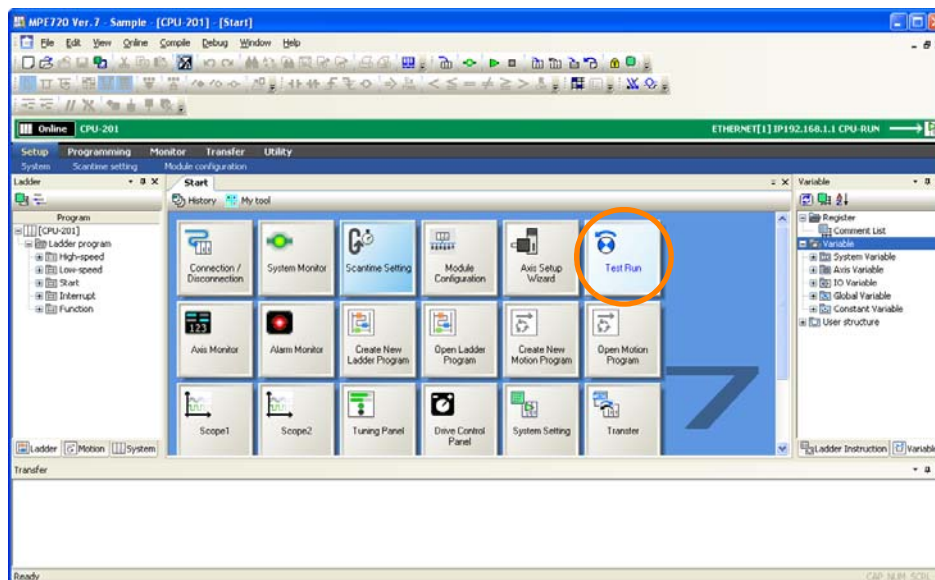

The Test Run Warning Dialog Box will be displayed.

2. Read the warnings and click the **Agree** Button.

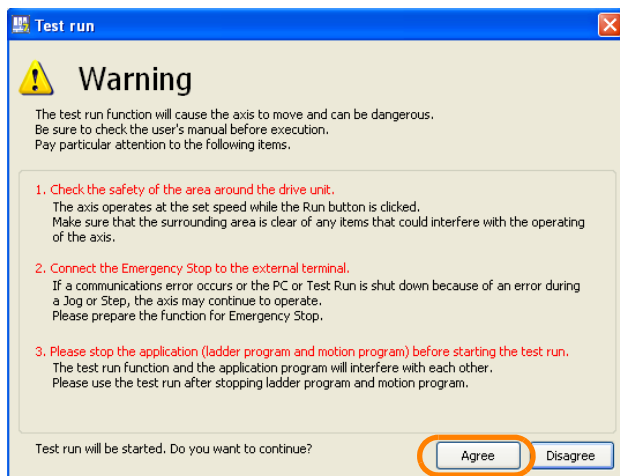

The Axis Dialog Box will be displayed.

3. Select the axis to test.

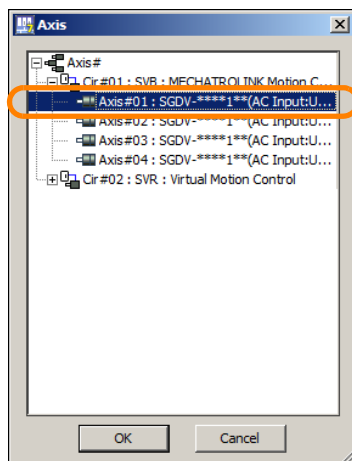

4. Click the **OK** Button.

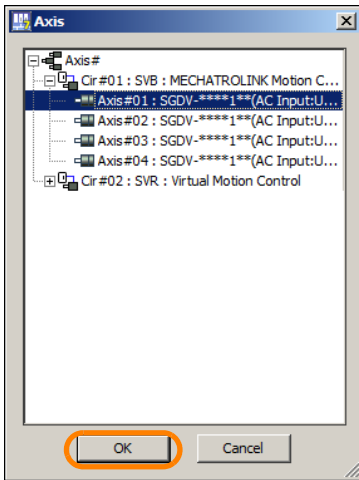

The following confirmation message about switching the axis will be displayed.

5. Click the **Yes** Button.

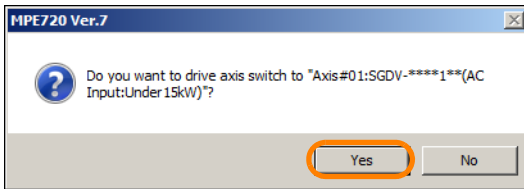

The Test Run Dialog Box will be displayed.

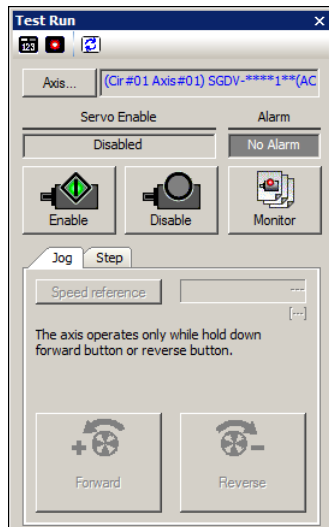



Information The Test Run can be performed only on the selected axis. To set up other axes, click the Axis Button and select the axis in the Axis Selection Dialog Box. Repeat this for each axis.

3.7.3 Test Run Dialog Box Details

This section provides a detailed description of the Test Run Dialog Box.

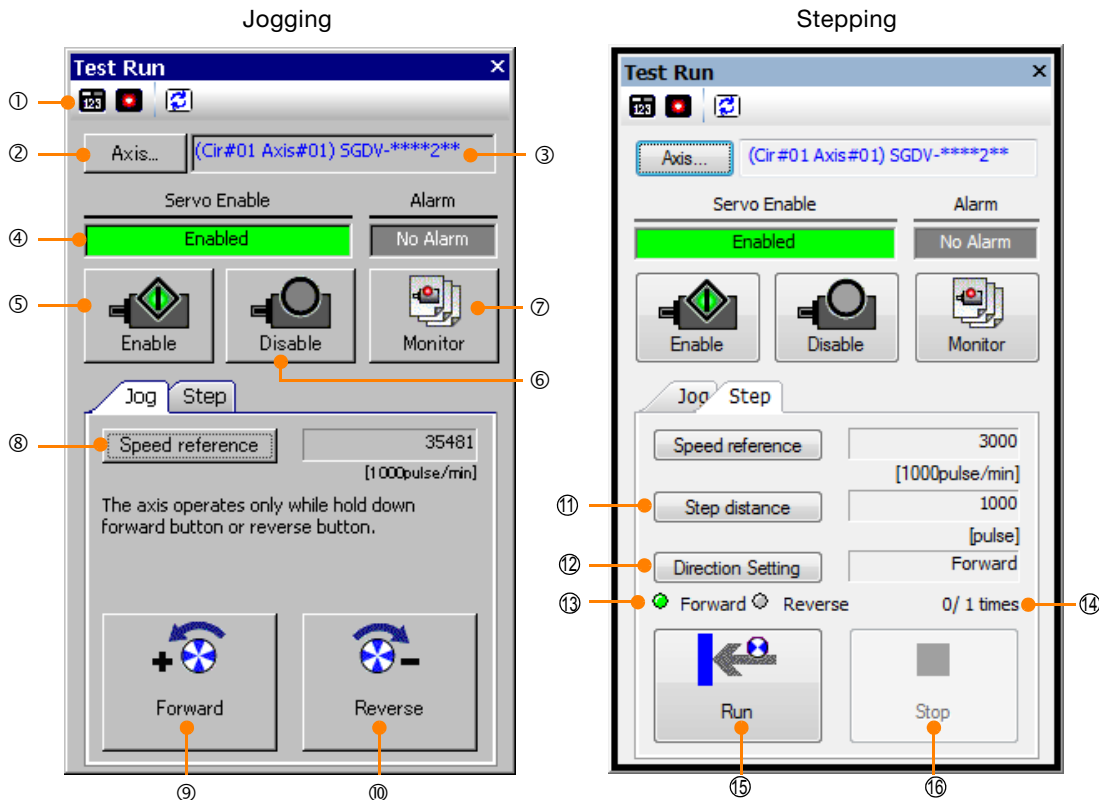
You can select jogging or stepping by clicking the tabs.



No.	Item	Function	
①	Tool Bar	Axis Monitor	Displays the Axis Monitor Tab Page in the Main Window.
		Alarm Monitor	Displays the Alarm Monitor Tab Page in the Main Window.
		Refresh	Updates the test run information.
②	Axis	Displays the Axis Selection Dialog Box.	
③	Axis Display	Displays the selected axis.	
④	Status	Displays the operating status of the axis and any alarms that occurred.	
⑤	Enable	Turns ON the axis servo.	
⑥	Disable	Turns OFF the axis servo.	
⑦	Monitor	Displays the Alarm/Warning Dialog Box.	
⑧	Speed Reference	Displays the Speed Reference Setting Dialog Box. Set the speed (speed reference value) for axis rotation.	
⑨	Forward	While this button is pressed, the axis rotates in the positive direction.	
⑩	Reverse	While this button is pressed, the axis rotates in the negative direction.	
⑪	Step Distance	Displays the Step Distance Setting Dialog Box. Set the step distance for the axis.	
⑫	Direction Setting	Displays the Direction Setting Dialog Box. Set the starting direction and the number of rotations for the step operation.	
⑬	Forward/Reverse Status	The  mark indicates the current step direction.	
⑭	Repetition Counter Status	Displays the repetition status as the current repetition count/set repetition count.	
⑮	Run	Performs stepping in the direction that was specified in the Direction Setting Dialog Box.	
⑯	Stop	Stops the stepping operation.	

Creating User Programs

4

This chapter describes the types of user programs and describes how to create and write them to the Controller.

4.1 User Program Types and Execution Timing 4-3

- 4.1.1 Ladder Programs 4-3
- 4.1.2 Motion Programs 4-9
- 4.1.3 Sequence Programs 4-21
- 4.1.4 The M-EXECUTOR 4-23
- 4.1.5 Registers 4-38

4.2 Creating Ladder Programs 4-48

4.3 Creating Motion Programs 4-52

- 4.3.1 Creating a Group Definition 4-52
- 4.3.2 Creating a Motion Main Program 4-53
- 4.3.3 Creating a Motion Subprogram 4-55

4.4 Creating a Sequence Program 4-57

- 4.4.1 Creating a Sequence Main Program 4-57
- 4.4.2 Creating a Sequence Subprogram 4-58

4.5 Transferring Data with the MPE720 4-60

- 4.5.1 Writing Parameters to the Machine Controller . . 4-61
- 4.5.2 Writing into a Project File 4-62
- 4.5.3 Reading from the Machine Controller 4-63
- 4.5.4 Reading from a Project File 4-64
- 4.5.5 Saving to Flash Memory 4-65
- 4.5.6 Using a CF Card (MP2200 Only) 4-66
- 4.5.7 Comparing to the Machine Controller 4-68
- 4.5.8 Comparing Flash Memory and RAM Data 4-68
- 4.5.9 Comparing to a Project File 4-68
- 4.5.10 Comparing to a CF Card 4-68

4.6 Data Transfer without Using the MPE720 . . . 4-69

- 4.6.1 Using a CF Card (MP2200 Only) 4-69
- 4.6.2 Using the MPLoader 4-72
- 4.6.3 Using the MPLoad Maker 4-74

4.1

User Program Types and Execution Timing

There are three types of user programs:

- Ladder programs
- Motion programs
- Sequence programs

This section describes these programs.

4.1.1 Ladder Programs

Ladder programs are managed as drawings (ladder diagrams) that are identified by their drawing numbers (DWG numbers). The ladder drawings form the basis of the ladder programs.

Drawing Types and Hierarchical Configuration

This section describes the types of ladder drawings and their hierarchical configuration.

◆ Types

Ladder drawings are divided into four different types based on their purpose.

- DWG.A (Startup Drawings)
This type of ladder drawing is used to set register data. These ladder drawings are executed before high-speed scan process drawings and low-speed scan process drawings.
- DWG.I (Interrupt Drawings)
This type of ladder drawing is used to perform processing with priority given to signals input from an Optional Module. These ladder drawings are executed with higher priority than high-speed scan process drawings regardless of the scan cycle.
- DWG.H (High-speed Scan Process Drawings)
This type of ladder drawing is used to perform motion control or high-speed I/O control.
- DWG.L (Low-speed Scan Process Drawings)
This type of ladder drawing is used for communications with HMIs and external devices as well as for standard I/O control.

The following table lists the priority, execution conditions, and maximum number of drawings for each type of ladder drawing.

Drawing Type	Priority*	Execution Condition	Maximum Number of Drawings
DWG.A (Startup Drawings)	1	Power ON (These drawings are executed once when the power supply is turned ON.)	64
DWG.I (Interrupt Drawings)	2	External interrupt (These drawings are executed when a DI interrupt or counter match interrupt is received from an Option Module.)	64
DWG.H (High-speed Scan Process Drawings)	3	Started at fixed intervals. (These drawings are executed once every high-speed scan.)	200
DWG.L (Low-speed Scan Process Drawings)	4	Started at fixed intervals. (These drawings are executed once every low-speed scan.)	500

* Drawings with lower numbers have higher priority.

◆ Hierarchical Configuration

There are four types of ladder drawings: parent drawings, child drawings, grandchild drawings, and operation error drawings.

- Parent Drawings
These drawings are automatically executed by the system program when the execution conditions are met.
- Child Drawings
These drawings are executed when they are called from a parent drawing with a SEE instruction.
- Grandchild Drawings
These drawings are executed when they are called from a child drawing with a SEE instruction.
- Operation Error Drawings
These drawings are automatically executed by the system program when an operation error occurs.

A parent drawing cannot call a child drawing from a different type of drawing. Similarly, a child drawing cannot call a grandchild drawing from a different type of drawing. A parent drawing cannot call a grandchild drawing directly. The parent drawing first must call the child drawing, and then the child drawing must call the grandchild drawing. This is called the hierarchical configuration of drawings.

The following figure shows the parent-child-grandchild structure in which a program is created.

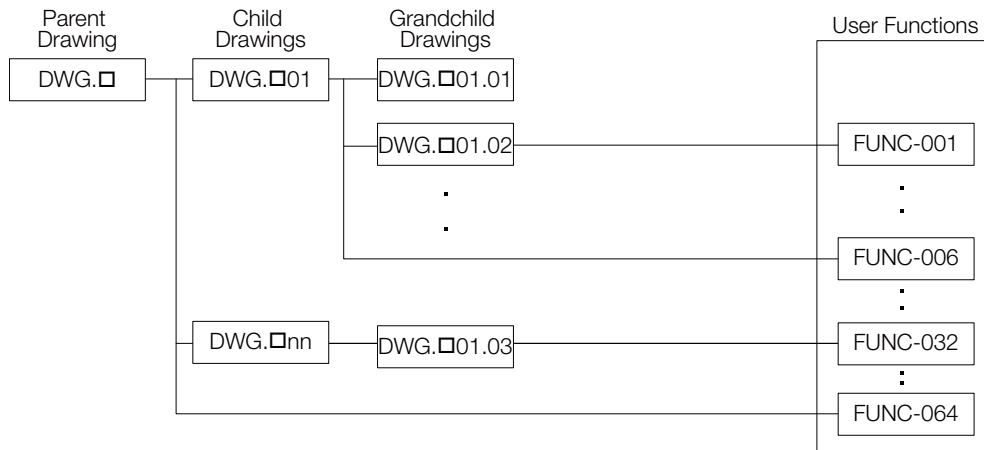

Note 1: □ = A, I, H, or L

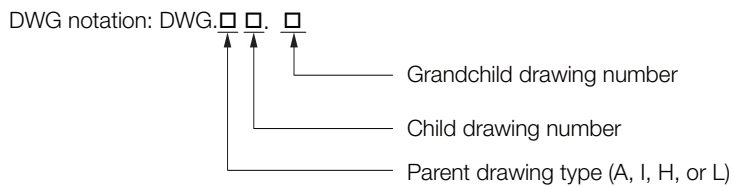

Note 2: The following notation is used for operation error drawings.

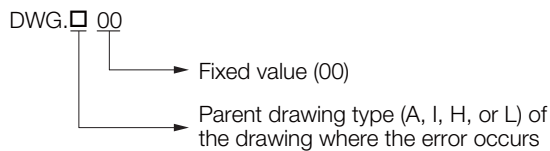

The breakdown of the number of ladder drawings in each category is given in the following table.

Drawings	Number of Drawings			
	DWG.A	DWG.I	DWG.H	DWG.L
Parent Drawings	1	1	1	1
Operation Error Drawings	1	1	1	1
Child Drawings	Total of 62 max.	Total of 62 max.	Total of 198 max.	Total of 498 max.
Grandchild Drawings				

Information There are separate functions that can be called from the drawings as required. Functions are executed when they are called from a parent, child, or grandchild drawing with the FUNC instruction. You can create up to 500 functions.

Controlling the Execution of Drawings

Drawings are executed based on their priorities, as shown in the following figure.

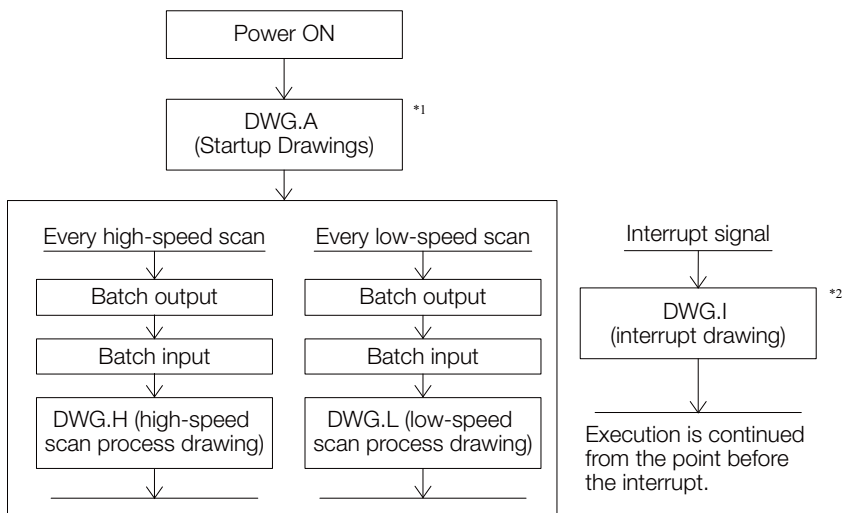

*1. DWG.A drawings are executed immediately after the power supply is turned ON.

*2. When an interrupt signal is input, execution of the DWG.I drawing is given priority even if execution of a DWG.H or DWG.L drawing is currently in progress.

Note: The parent drawing of each drawing is automatically called and executed by the system.

◆ Execution Processing of Drawings

The drawings are executed by calling them from the top to the bottom, following the hierarchy of the drawings. The following figure illustrates the execution processing of a high-speed scan drawing (DWG.H).

Execution is started by the system program when the execution condition is met.

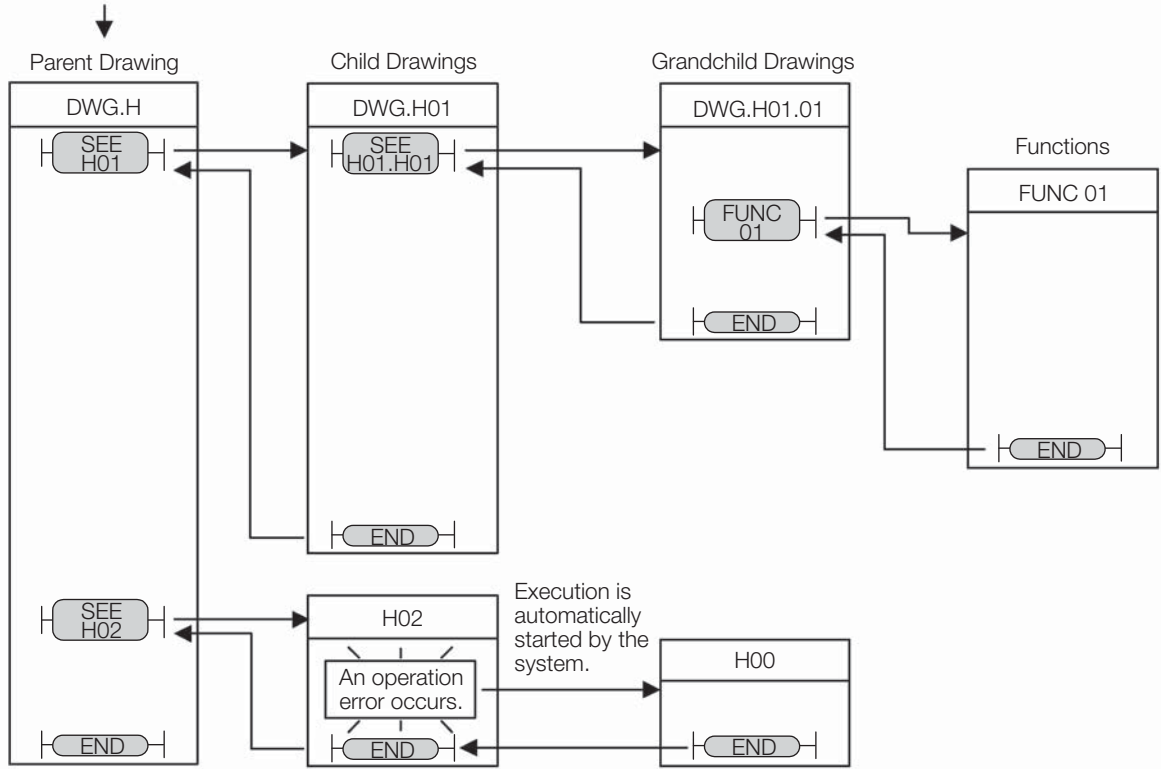

- Note: 1. The parent drawing is automatically called and executed by the system. Child drawings and grandchild drawings are executed by calling them from a parent drawing or a child drawing using the SEE instruction.
2. You can call functions from any drawing. You can also call functions from other functions.
3. If an operation error occurs, the operation error drawing for the drawing type will be started automatically.
4. Always specify 00 as the drawing number for operation error drawings.

◆ Scheduling the Execution of High-speed and Low-speed Scan Process Drawings

High-speed scan process drawings (DWG.H) and low-speed scan process drawings (DWG.L) cannot be executed at the same time. DWG.L drawings are executed during the idle time of DWG.H drawings.

The period during which DWG.H drawings are executed is called the high-speed scan time. The period during which DWG.L drawings are executed is called the low-speed scan time.

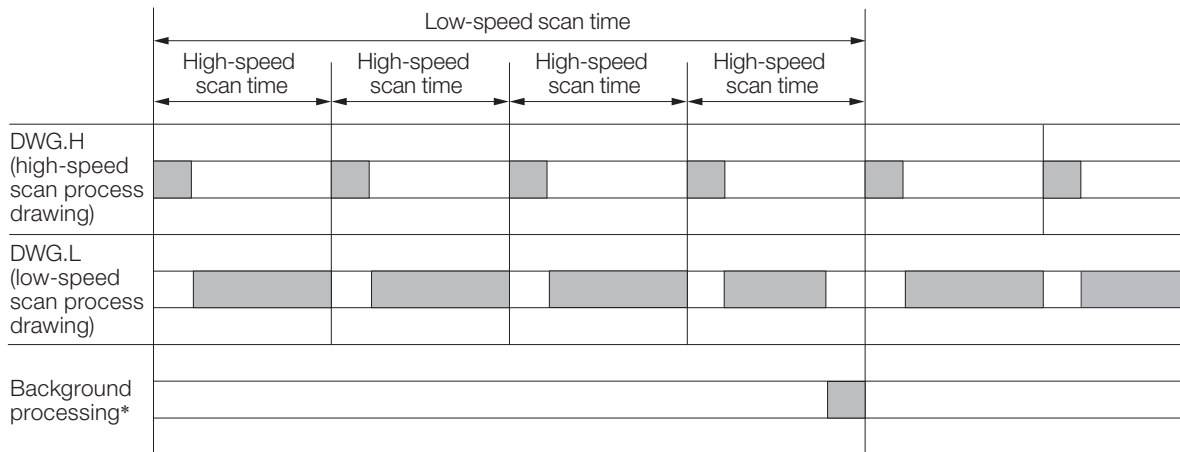

Actual processing time during the scan

* Background processing is used to execute internal system processing, such as communications processing.

◆ Setting the High-speed and Low-speed Scan Times

Use MPE720 version 7 and perform the procedure given below to set the high-speed and low-speed scan times.

1. Stop the CPU Module.
2. Click **Scantime Setting** in the My Tool View.
The following dialog box will be displayed.

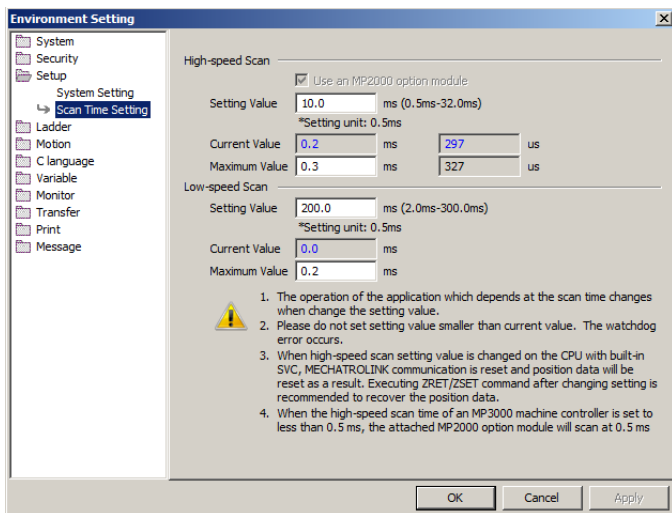

- Setting Value: Enter the scan time settings.
- Current Value: A value of 0.0 ms is displayed when the MPE720 is offline. Otherwise, the actual processing times for the scans are displayed.
- Maximum Value: The maximum processing time for the scan is displayed. You can set the maximum value. The setting is retained until it is exceeded.

3. Enter the high-speed scan time in the **Setting Value Box under **High-speed Scan**. Enter the low-speed scan time in the **Setting Value Box** under **Low-speed Scan**.**

The following table shows the possible set values and default values for each scan time.

Item	Possible Set Values	Default
High-speed Scan Time	0.5 to 32.0 ms (in 0.5-ms increments)	4.0 ms
Low-speed Scan Time	2.0 to 300.0 ms (in 0.5-ms increments)	200.0 ms

Note: The possible set values and default values depend on the model. Refer to the user’s manual for the Module you are using for details.

4. Click the **OK Button.**

The settings will be saved and the Environment Setting Dialog Box will close.



Important

Observe the following precautions when setting the high-speed scan time and low-speed scan time.

1. Set the scan set value so that it is 1.25 times greater than the maximum value.
If the scan set value is too close to the maximum value, the refresh rate of the MPE720 window will noticeably drop and can cause communications timeout errors to occur. If the maximum value exceeds the scan set value, a watchdog error may occur and cause the Machine Controller system to shut down.
2. If you are using MECHATROLINK-II or MECHATROLINK-III, set values that are an integral multiple of the communications cycle. If you change the communications cycle, check the scan time set values.
3. Do not change the scan set value while the Servo is ON. Never change the scan set value while an axis is in motion (i.e., while the motor is rotating). Doing so may cause the motor to rotate out of control.
4. After changing or setting a scan time, always save the data to flash memory.

Functions

Functions are executed when they are called from a parent, child, or grandchild drawing with the FUNC instruction.

Functions can be freely called from any drawing. The same function can be called simultaneously from different types of drawings or different levels of drawings. You can also call functions from other functions that you have created.

The use of functions provides the following merits:

- Easy user program modularization
- Easy user program creation and maintenance

You can use standard functions that are provided by the system, and you can define user functions.

◆ Standard System Functions

The following functions for communications and other purposes are provided as standard functions in the system. You cannot change the system functions.

Symbol	Function
COUNTER	Counter
FINFOUT	First-in First-out
TRACE	Trace
DTRC-RD	Read Data Trace
MSG-SND	Send Message
MSG-RCV	Receive Message
MOTREG-W	Write Motion Register
MOTREG-R	Read Motion Register

◆ User Functions

You can freely program the body of a user function and program the user function definitions. The maximum number of user functions is 500 drawings.

Note: Refer to the following manuals for details on how to define functions.

- 📖 MP900/MP2000 Series User's Manual, Ladder Programming (Manual No.: SIEZ-C887-1.2)
- 📖 MP2000 Series User's Manual for Motion Programming (Manual No.: SIEP C880700 38)
- 📖 MP900/MP2000 Series New Ladder Editor Programming Manual (Manual No.: SIEZ-C887-13.1)
- 📖 MP900/MP2000 Series New Ladder Editor User's Manual (Manual No.: SIEZ-C887-13.2)

4.1.2 Motion Programs

A motion program is a program that is written in a text-based motion language.

There are two types of motion programs.

Type	Designation Method	Features	Number of Programs
Main programs	MPM□□□ (□□□ = 1 to 256)	<ul style="list-style-type: none"> • Main programs are called from a DWG.H drawing. • Main programs are called from the M-EXECUTOR program execution definitions. 	You can create up to 256 motion programs, including the following programs: <ul style="list-style-type: none"> • Motion main programs • Motion subprograms • Sequence main programs • Sequence subprograms
Subprograms	MPS□□□ (□□□ = 1 to 256)	Subprograms are called from a main program.	

Note: There are cases when the M-EXECUTOR cannot be used. Refer to the following section for details.

📖 *The M-EXECUTOR (page 4-23)*



Important

1. The same numbers are used to manage the motion programs and sequence programs. Use a unique number for each program.
 - Motion program numbers are given in the form MPM□□□ or MPS□□□.
 - Sequence program numbers are given in the form SPM□□□ or SPS□□□.
2. The number of motion programs that can be executed simultaneously depends on the model of the Machine Controller. If the number of simultaneously executable programs is exceeded, an alarm will occur (No System Work Available Error).
 - The No System Work Available Error is indicated by bit E in the Status Flags of the motion program.

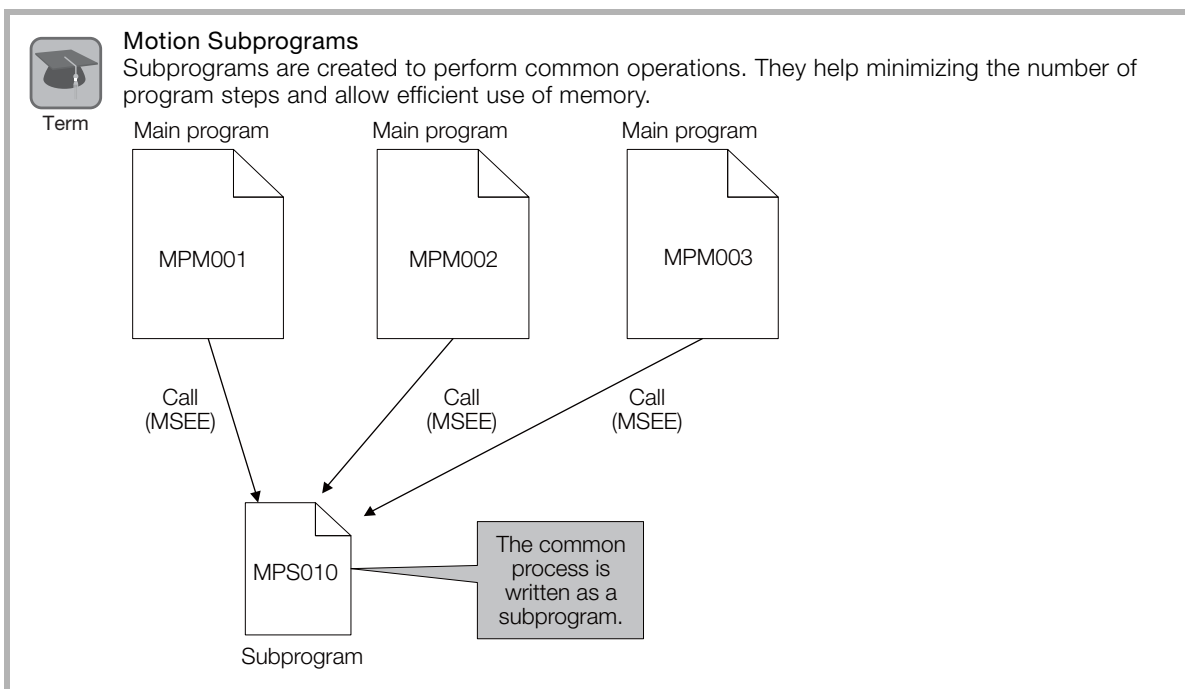

Motion Program Execution

Motion programs are called with an MSEE instruction from a ladder program in an H drawing.

Information You can also register the motion program in the M-EXECUTOR (Motion Executor) to call it. Refer to the following section for details.

 *The M-EXECUTOR (page 4-23)*

After you create the motion program, place a Call Motion Program (MSEE) instruction in the ladder program of an H drawing. Motion programs can be called from any H drawing, regardless of whether it is a parent, child, or grandchild drawing.

The following figure shows an execution example.

Execution is started by the system program when the execution condition is met.

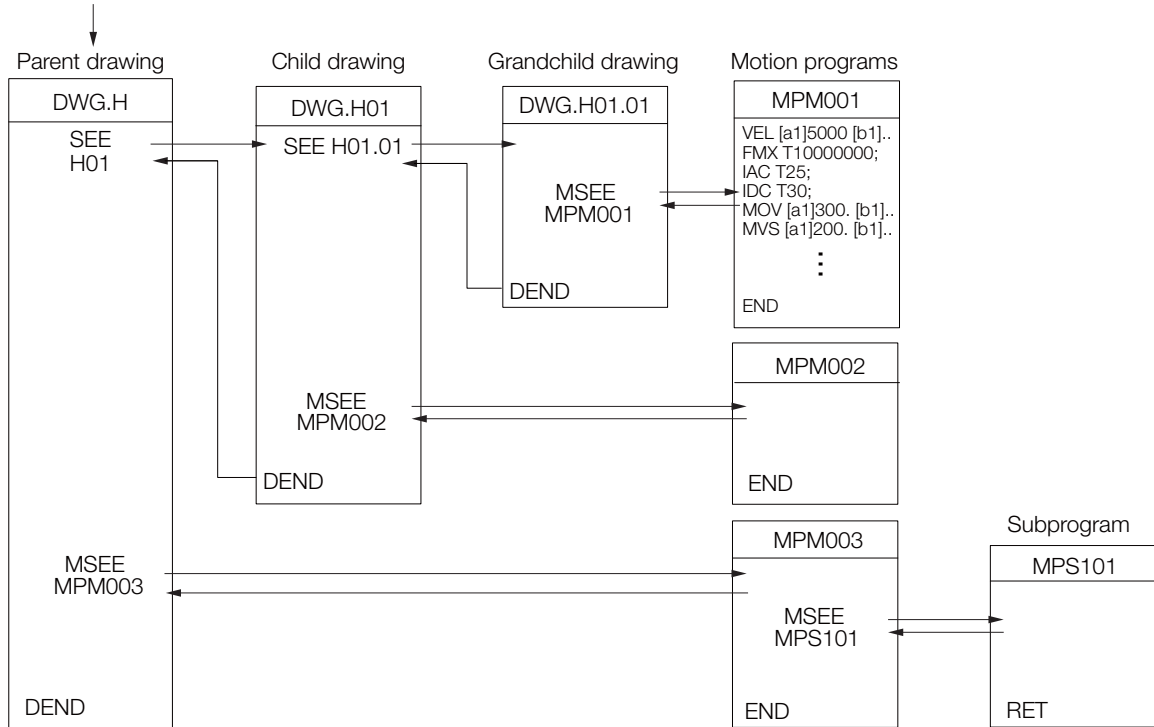

The ladder instruction in the H drawing is executed every high-speed scan cycle according to the hierarchical organization of parent-child-grandchild drawings.

The above programming only prepares for execution of the motion program. The motion program is not executed when the MSEE instruction is inserted. To start the motion program after inserting the MSEE instruction, use a control signal to turn ON the Request for Start of Program Operation.

The motion program is executed in the scan cycle, but unlike ladder programs, the entire program is not executed in a single scan. Execution of motion programs is controlled by the system.

Information The following points must be taken into consideration when executing motion programs.

- Motion programs that are registered in the M-EXECUTOR cannot be executed with MSEE instructions.
- More than one instance of the same motion program (i.e., the same program number) cannot be executed with MSEE instructions.
- Subprograms (MPS□□□) cannot be executed with MSEE instructions in a ladder program. You can call subprograms only from motion programs and motion subprograms (MPM□□□ and MPS□□□).
- You cannot call the same subprogram more than once at the same time.
- Sequence programs (SPM□□□ and SPS□□□) cannot be called with MSEE instructions from a ladder program for the MP2300, CPU-01, or CPU-03.

Specifying Motion Programs

There are two methods that you can use to specify motion programs.

- Calling the motion program by specifying it directly
- Calling the motion program by specifying it indirectly

These two methods are described below.

◆ Calling the Motion Program by Specifying It Directly

Direct designation is used to call a motion program by specifying its program number (MPM□□□) directly.

To call the motion program from a ladder program with the MSEE instruction, specify the program number in the Program Number operand of the MSEE instruction.

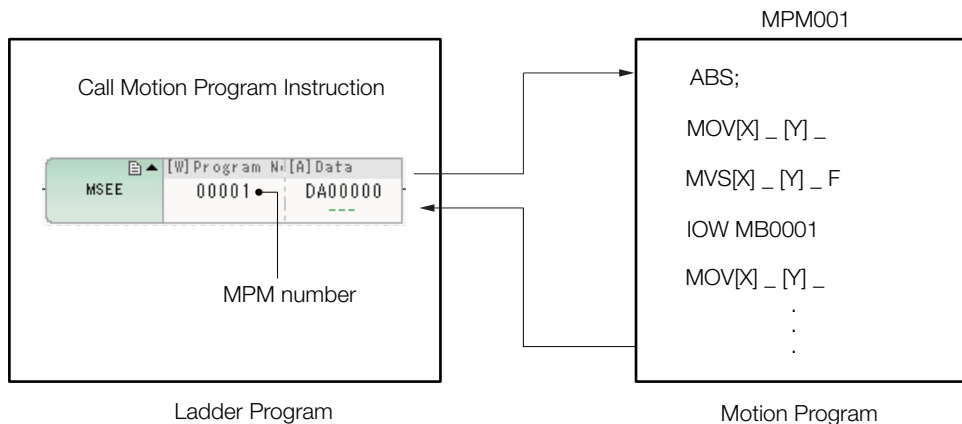

◆ Calling the Motion Program by Specifying It Indirectly

Indirect designation is used to call a motion program by specifying its number in a register.

In this method, the program (MPM□□□) whose number is the same as the value that is stored in the register is called.

To call the motion program from a ladder program with an MSEE instruction, use the Program Number operand of the MSEE instruction to specify the M or D register that indirectly designates the motion program.

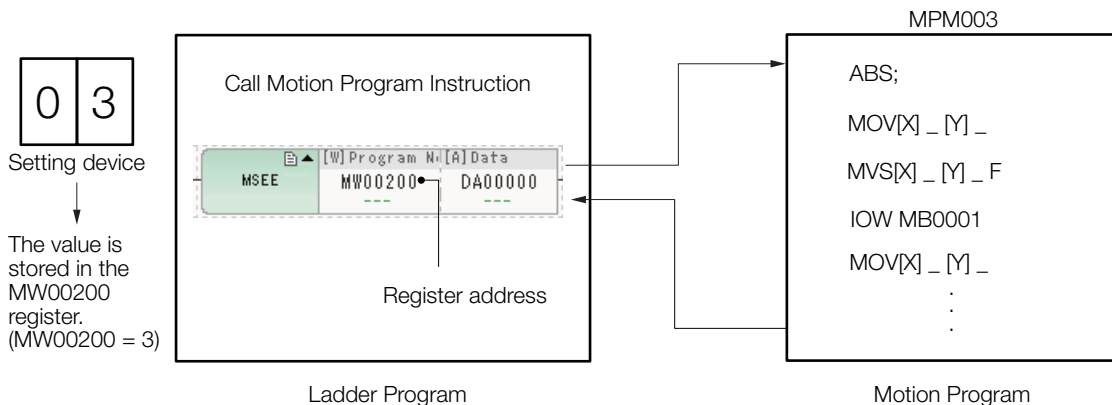

Work Registers

Work registers are used to set and monitor motion programs.

The first work register for a motion program that is called with an MSEE instruction is specified in the MSEE instruction in the ladder program. The following figure shows the structure of the work registers.

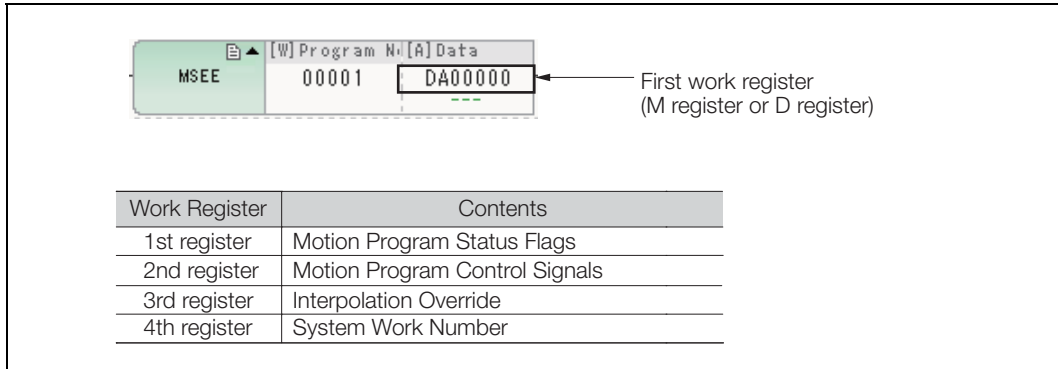

◆ Motion Program Status Flags

The Motion Program Status Flags give the execution condition of the motion program. The following table describes the meanings of the Status Flags.

Bit No.	Status
0	Program is being executed.
1	Program is paused.
2	Program is stopped due to a stop request (for system use).
3	Reserved for system.
4	Program single-block execution is stopped.
5	Reserved for system.
6	Reserved for system.
7	Reserved for system.
8	There is a program alarm.
9	Execution is stopped at a breakpoint.
A	Reserved for system.
B	The program is in Debug Mode (EWS debugging).
C	Program Type, 0: Motion program
D	Start Request History
E	No System Work Available Error Execution Scan Error
F	Main Program Number Limit Exceeded Error

Note: If a program alarm occurs, motion program error information is provided in the Motion Alarm Dialog Box and in the S registers.

◆ Control Signals

To control the execution of a motion program, you must input program control signals (Request for Start of Program Operation, or Request for Stop of Program, etc.). The following table describes the control signals for motion programs.

Bit No.	Signal Name	Signal Type
0	Request for Start of Program Operation	Differential or NO contact input
1	Request for Pause of Program	NO contact
2	Request for Stop of Program	NO contact
3	Program Single-block Mode Selection	NO contact
4	Program Single-block Start Request	Differential or NO contact input
5	Alarm Reset Request	NO contact
6	Request for Start of Continuous Program Operation	Differential or NO contact input
7	Reserved for system.	–
8	Skip 1 Information	NO contact
9	Skip 2 Information	NO contact
A	Reserved for system.	–
B	Reserved for system.	–
C	Reserved for system.	–
D	System Work Number Setting ^{*1}	NO contact
E	Interpolation Override Setting ^{*2}	NO contact
F	Reserved for system.	–

*1. System Work Number Setting

- When the Motion Program Is Registered in M-EXECUTOR:
The system work number cannot be specified. The system will use the definition number as the system work number.
- When a Motion Program Is Called from a Ladder Program with an MSEE Instruction:
OFF: The system will use an automatically acquired system work number.
The system work number will be different each time.
ON: The work number that is specified by the system will be used.
However, if the work number is assigned to the M-EXECUTOR, a No System Work Available Error (Status Flag Bit E) is reported.

*2. Interpolation Override Setting

- OFF: The interpolation override is always 100%.
- ON: The interpolation override in the parameter setting is used.

Note: 1. Use the specified signal types for the ladder program inputs.

- 2. If the Request for Start of Program Operation control signal is ON when the power supply is turned ON, the motion program with the specified program number will be executed.

■ Motion Program Control Signals Timing Chart

Timing chart examples for axis operations and status flags after a control signal is input are provided below.

• Request for Start of Program Operation

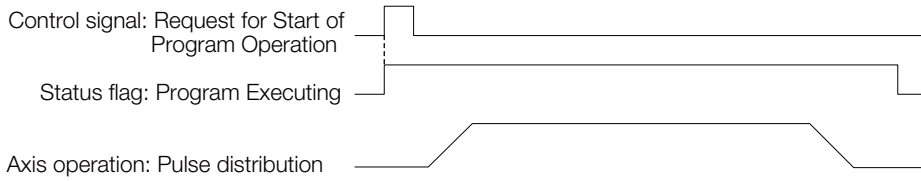

• Request for Pause

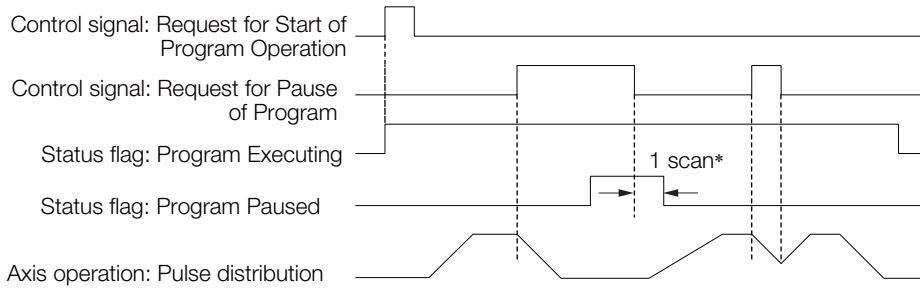

* Status flags related to control signal input are updated after one scan.

• Request for Stop

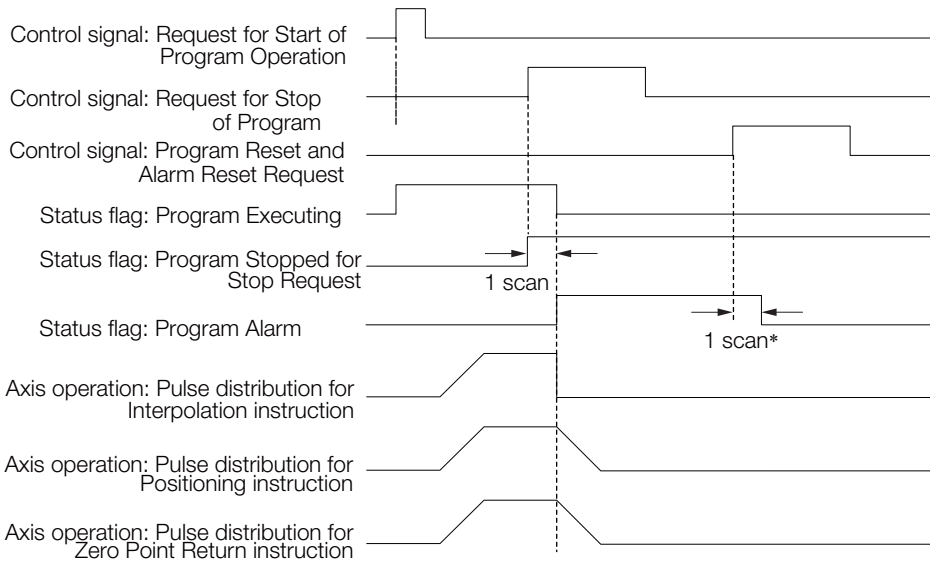

* Status flags related to control signal input are updated after one scan.

• If a Motion Program Alarm Occurs

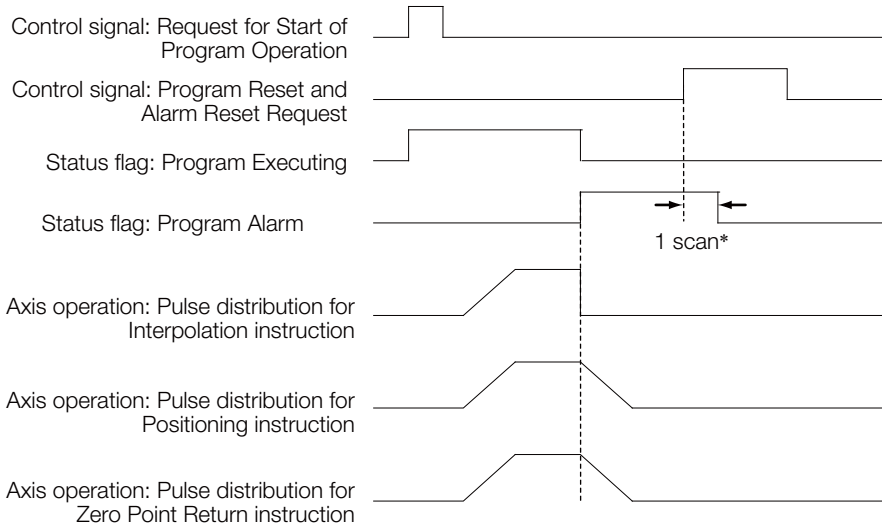

* Status flags related to control signal input are updated after one scan.



Important

1. If the Request for Stop of Program control signal is turned ON while the axis is being controlled for a motion language instruction, an alarm will occur.
2. If the Request for Stop of Program control signal is turned ON while the axis is being controlled for an interpolation motion language instruction, the axes will stop immediately. To perform a deceleration stop, use the Request for Pause of Operation control signal.
3. The Request for Pause of Program control signal is not acknowledged while a Zero Point Return (ZRN) instruction is being executed. To stop the operation, use the Request for Stop of Program control signal.
4. If a motion program alarm occurs while an axis is in motion, the axis stops immediately.

◆ Interpolation Override

The interpolation override is used to change the output ratio of the axis movement speed reference for interpolation motion language instructions.

Set the override value to use when executing interpolation instructions (MVS, MCW, MCC, or SKP).

The interpolation override is valid only when bit E (Interpolation Override Setting) in the control signals is ON.

The setting range of the interpolation override is 0 to 32,767.

Unit: 1 = 0.01%

◆ System Work Numbers

When you call a motion program from a ladder program with the MSEE instruction, set the system work number to use to call the motion program. This system work number is valid only when bit D (System Work Number Setting) of the control signals is ON.

Setting range: 1 to 16



Important

When using MSEE instructions in ladder programs along with the M-EXECUTOR, do not specify the system work numbers that are for the M-EXECUTOR in the MSEE instructions in the ladder programs. If you specify one, a No System Work Available Error will occur.
System work numbers for the M-EXECUTOR: 0 to the set value of the number of program definitions

Information You cannot set the system work numbers when you use the M-EXECUTOR. The system will use system work numbers that are the same as the definition numbers.

Using the Work Registers

The work registers for motion program are used differently depending on whether the motion program is called from a ladder program using an MSEE instruction, or the motion program is registered in the M-EXECUTOR program execution definitions.

This section describes these two methods.

◆ When the Motion Program Is Called from the Ladder Program with an MSEE Instruction

When a motion program is called from the ladder program with an MSEE instruction, the motion program is controlled by either a sequence program or a ladder program.

To use this method, include the MSEE instruction in a ladder H drawing. In this case, the MSEE work registers are used to set and monitor the motion program.

The following figure shows a setting example.

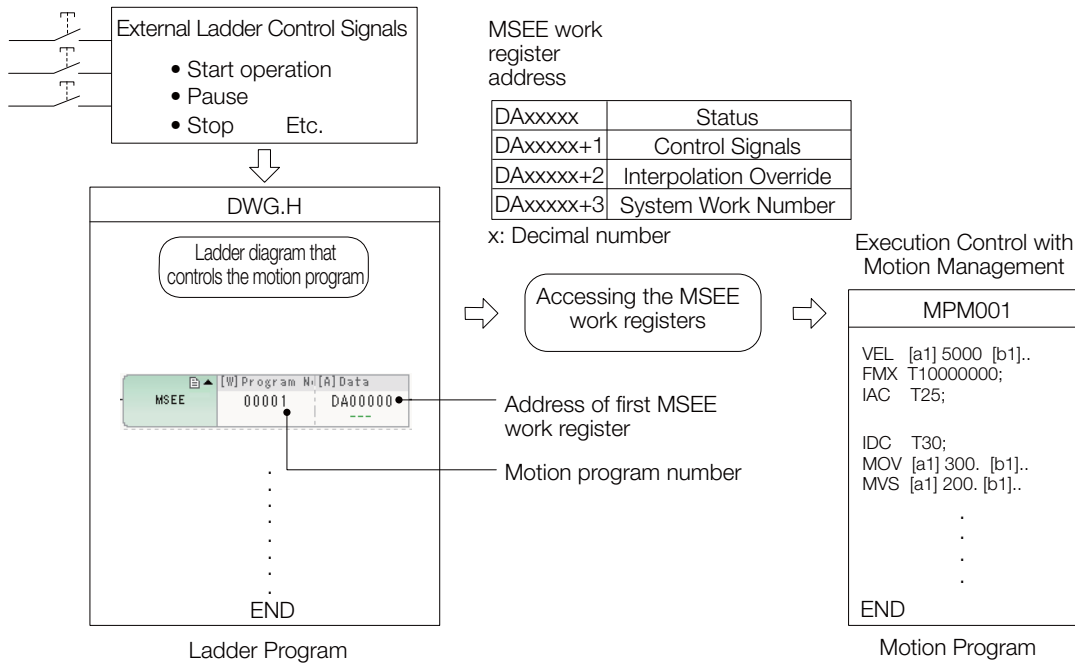

The next page shows an example of a ladder program that controls the motion program.

■ Ladder Program Example

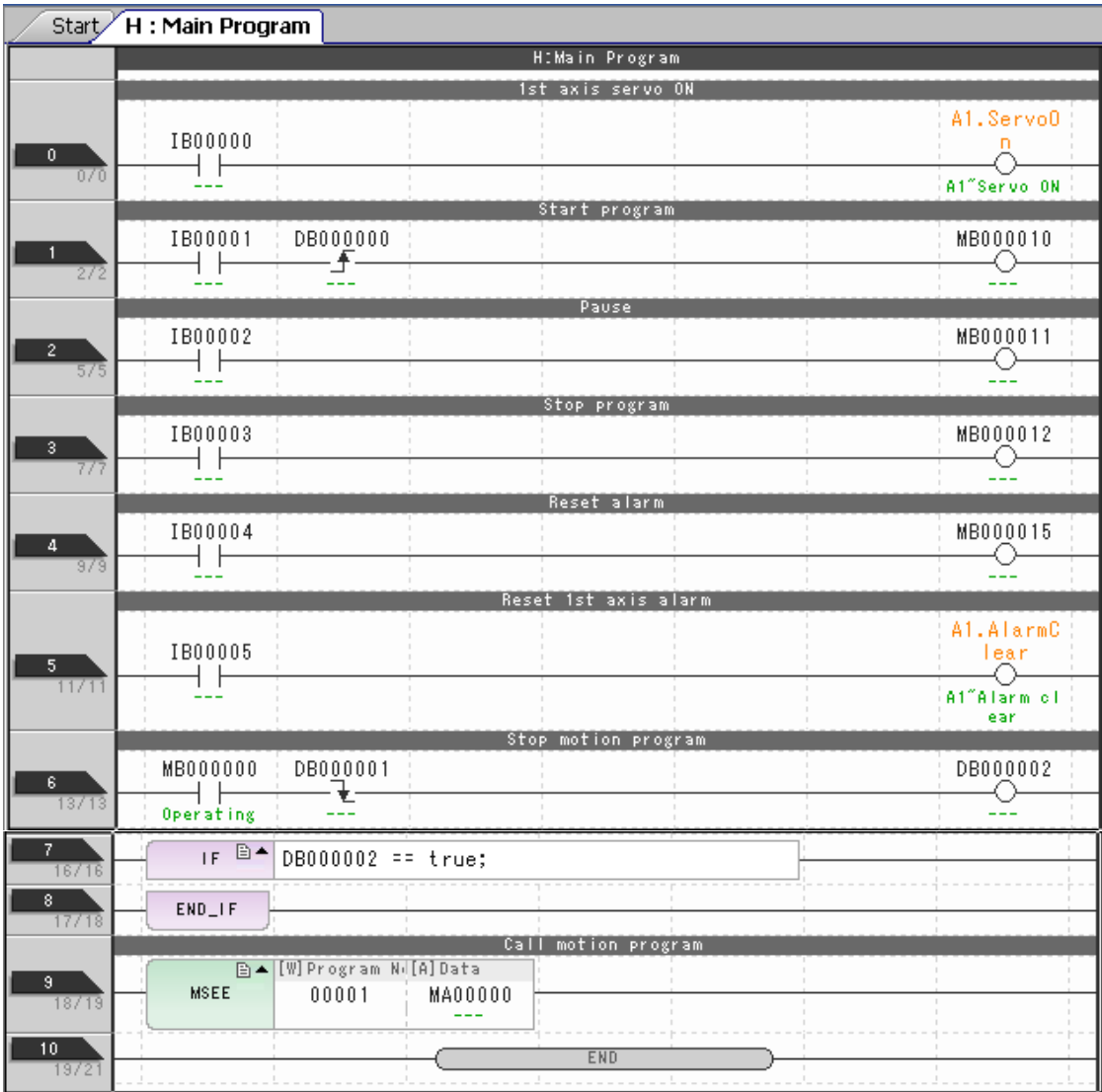

Monitoring the Execution Information on the Motion Program with S Registers

You can monitor execution information on the motion program with the S registers (SW03200 to SW05119 and SW08192 to SW09215).

The execution information is monitored differently, depending on whether the motion program is called from a ladder program with an MSEE instruction, or the motion program is registered in the M-EXECUTOR program execution definitions.

This section describes these two monitoring methods.

◆ When the Motion Program Is Called from the Ladder Program with an MSEE Instruction

When a motion program is called from the ladder program with an MSEE instruction, the monitoring method depends on the setting of bit D (System Work Number Setting) in the Motion Program Control Signals.

■ When Bit D (System Work Number Setting) in the Motion Program Control Signal Is ON

The execution information is reported in the Work n Program Information registers (SW03264 to SW05119 and SW08192 to SW09215).

For example, if the system work number is 1, you can monitor the execution information of the motion program with the Work 1 Program Information registers (SW03264 to SW03321).

■ When Bit D (System Work Number Setting) in the Motion Program Control Signal Is OFF

The system automatically determines the system work number to use. You can check the work numbers that are in use in the Active Program Numbers registers (SW03200 to SW03215).

For example, to monitor the MPM001 motion program and SW03202 is 001, that means the system number is 3. You can therefore monitor the execution information of the MPM001 motion program using the Work 3 Program Information registers (SW03380 to SW03437).

◆ When the Motion Program Is Registered in M-EXECUTOR Program Execution Definitions:

When the motion program is registered in the M-EXECUTOR program execution definitions, the system work number will be the same as the definition number.

For example, if the motion program is registered with definition number 3, system work number 3 will be used. In this case, you can monitor the execution information of the motion program with the Work 3 Program Information registers (SW03380 to SW03437).

Refer to the following section for the register ranges for the motion program execution information.

■ Register Ranges for Motion Program Execution Information

Motion Program Execution Information			Active Program Numbers				
SW03200	Active Program Numbers (the numbers of the currently executing main programs)	16 W	SW03200	Number of Program Using Work Number 1			
SW03216	Reserved for system.	16 W	SW03201	Number of Program Using Work Number 2			
SW03232	Program Execution Bits (ON if execution is in progress.)	16 W	SW03202	Number of Program Using Work Number 3			
SW03248	Reserved for system.	16 W	SW03203	Number of Program Using Work Number 4			
SW03264	Work 1 Program Information	58 W	SW03204	Number of Program Using Work Number 5			
SW03322	Work 2 Program Information	58 W	SW03205	Number of Program Using Work Number 6			
SW03380	Work 3 Program Information	58 W	SW03206	Number of Program Using Work Number 7			
SW03438	Work 4 Program Information	58 W	SW03207	Number of Program Using Work Number 8			
SW03496	Work 5 Program Information	58 W	SW03208	Number of Program Using Work Number 9			
SW03554	Work 6 Program Information	58 W	SW03209	Number of Program Using Work Number 10			
SW03612	Work 7 Program Information	58 W	SW03210	Number of Program Using Work Number 11			
SW03670	Work 8 Program Information	58 W	SW03211	Number of Program Using Work Number 12			
SW03728	Work 9 Program Information	58 W	SW03212	Number of Program Using Work Number 13			
SW03786	Work 10 Program Information	58 W	SW03213	Number of Program Using Work Number 14			
SW03844	Work 11 Program Information	58 W	SW03214	Number of Program Using Work Number 15			
SW03902	Work 12 Program Information	58 W	SW03215	Number of Program Using Work Number 16			
SW03960	Work 13 Program Information	58 W		Program Execution Bits			
SW04018	Work 14 Program Information	58 W	SW03232			MPo016(Bit F) to MPo001(Bit 0)	
SW04076	Work 15 Program Information	58 W	SW03233			MPo032(Bit F) to MPo017(Bit 0)	
SW04134	Work 16 Program Information	58 W	SW03234			MPo048(Bit F) to MPo033(Bit 0)	
SW04192	Reserved for system.	928 W	SW03235			MPo054(Bit F) to MPo049(Bit 0)	
SW05120	Reserved for system.	64 W	SW03236			MPo080(Bit F) to MPo055(Bit 0)	
			SW03237			MPo096(Bit F) to MPo081(Bit 0)	
			SW03238			MPo112(Bit F) to MPo097(Bit 0)	
			SW03239			MPo128(Bit F) to MPo113(Bit 0)	
			SW03240			MPo144(Bit F) to MPo129(Bit 0)	
			SW03241	MPo160(Bit F) to MPo145(Bit 0)			
			SW03242	MPo176(Bit F) to MPo161(Bit 0)			
			SW03243	MPo192(Bit F) to MPo177(Bit 0)			
			SW03244	MPo208(Bit F) to MPo193(Bit 0)			
			SW03245	MPo224(Bit F) to MPo209(Bit 0)			
			SW03246	MPo240(Bit F) to MPo225(Bit 0)			
			SW03247	MPo256(Bit F) to MPo241(Bit 0)			

Note: o is M or S.

■ Contents of Work n Program Information

Work n Program Information

+0	Program Status	
+1	Program Control Signals	
+2	Parallel Fork 0 Information	3 W
+5	Parallel Fork 1 Information	3 W
+8	Parallel Fork 2 Information	3 W
+11	Parallel Fork 3 Information	3 W
+14	Parallel Fork 4 Information	3 W
+17	Parallel Fork 5 Information	3 W
+20	Parallel Fork 6 Information	3 W
+23	Parallel Fork 7 Information	3 W
+26	Logical Axis 1 Program Current Position	2 W
+28	Logical Axis 2 Program Current Position	2 W
+30	Logical Axis 3 Program Current Position	2 W
+32	Logical Axis 4 Program Current Position	2 W
+34	Logical Axis 5 Program Current Position	2 W
+36	Logical Axis 6 Program Current Position	2 W
+38	Logical Axis 7 Program Current Position	2 W
+40	Logical Axis 8 Program Current Position	2 W
+42	Logical Axis 9 Program Current Position	2 W
+44	Logical Axis 10 Program Current Position	2 W
+46	Logical Axis 11 Program Current Position	2 W
+48	Logical Axis 12 Program Current Position	2 W
+50	Logical Axis 13 Program Current Position	2 W
+52	Logical Axis 14 Program Current Position	2 W
+54	Logical Axis 15 Program Current Position	2 W
+56	Logical Axis 16 Program Current Position	2 W

Active Program Numbers
Current Block Number
Alarm Code

4.1.3 Sequence Programs

A sequence program is written in a text-based motion language. There are two types of sequence programs.

Type	Designation Method	Features	Number of Programs
Main programs	SPM□□□ (□□□ = 1 to 256)	Main programs are called from the M-EXECUTOR program execution definitions.	You can create up to 256 motion programs, including the following programs: <ul style="list-style-type: none"> • Motion main programs • Motion subprograms • Sequence main programs • Sequence subprograms
Subprograms	SPS□□□ (□□□ = 1 to 256)	Subprograms are called from a main program.	



The same numbers are used to manage the sequence programs and motion programs. Use a unique number for each program.

- Motion program numbers are given in the form MPM□□□ or MPS□□□.
- Sequence program numbers are given in the form SPM□□□ or SPS□□□.

Sequence Program Execution

A sequence program is executed by registering it in the M-EXECUTOR execution definitions. The sequence programs are executed in ascending order. The following figure shows an execution example.

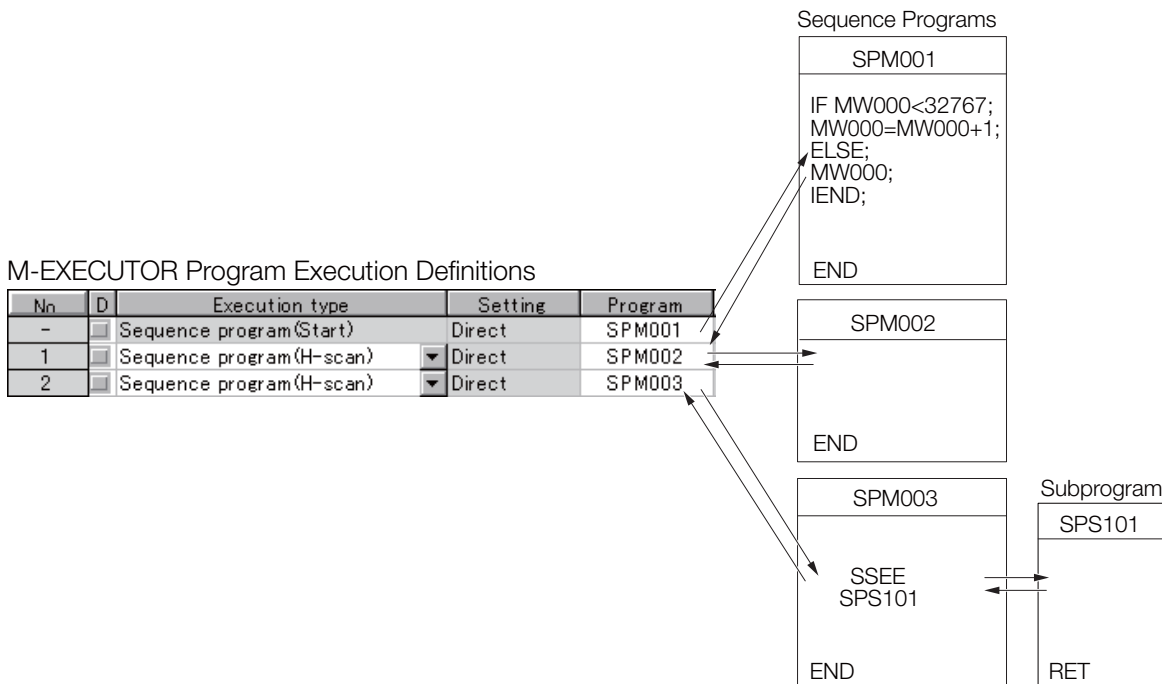

If the execution type is set to an H-scan sequence program or L-scan sequence program, then the program will be executed as soon as the definition is saved. If the execution type is set to a startup sequence program, then the program will be executed the next time when the power supply is turned ON.

Specifying Sequence Programs

Sequence programs must be specified directly. Indirect designations cannot be used. Specify the program number of the sequence program to execute (SPM□□□).

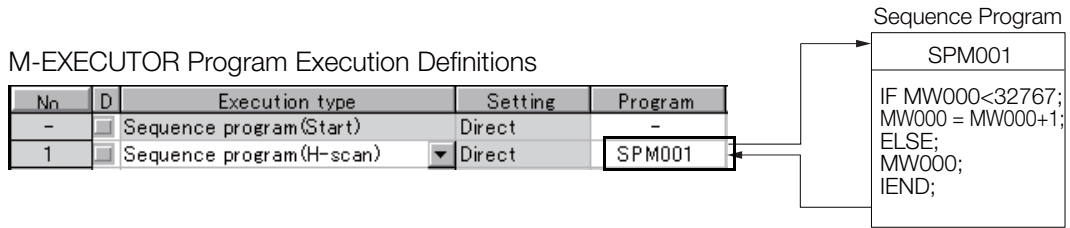

Work Registers

Work registers are used to monitor sequence programs.

The work registers have Status Flags inside the M-EXECUTOR control registers, in the same way as motion programs that are registered in the M-EXECUTOR.

◆ Sequence Program Status Flags

The Sequence Program Status Flags give the execution condition of the sequence program.

The following table describes the meanings of the Status Flags.

Bit No.	Status
0	Program is being executed.
1	Reserved for system.
2	Reserved for system.
3	Reserved for system.
4	Reserved for system.
5	Reserved for system.
6	Reserved for system.
7	Reserved for system.
8	There is a program alarm.
9	Execution is stopped at a breakpoint.
A	Reserved for system.
B	The program is in Debug Mode (EWS debugging).
C	Program Type, 1: Sequence program
D	Start Request History
E	Reserved for system.
F	Reserved for system.

Information

Sequence Program Alarms

If an error is detected when a sequence subprogram is called with an SSEE instruction, bit 8 (Program Alarm) turns ON. When the error is removed, this bit turns OFF.

The following errors can occur.

- The called program is not registered.
- The called program is not a sequence program.
- The called program is not a subprogram (a main program was called).
- Called Program Number Limit Exceeded Error
- Too Many Nesting Levels Error

4.1.4 The M-EXECUTOR

This section describes the functionality of the M-EXECUTOR Motion Executor and the contents of its various displays.



Term The M-EXECUTOR is a software module that executes motion and sequence programs.



Important The M-EXECUTOR software module that executes motion and sequence programs cannot be used with the following Machine Controllers and CPU Modules:

- MP2300 Basic Module
- CPU-01 and CPU-02 Modules

Refer to the following manual for details.

📖 MP2200 User's Manual (Manual No.: SIEP C880700 14)

Introduction

The M-EXECUTOR provides the following merits:

- Motion programs can be executed without using a ladder program.
Motion programs can be executed without placing MSEE instructions in the ladder programs.

Information It is still possible to use MSEE instructions in the ladder programs.

- Motion programs can be controlled without using the ladder programs.
Motion programs can be controlled directly from a host PLC.
- Sequence control can be written in motion language.
A sequence program can be used in place of a ladder program.
Refer to the following manuals for instructions that can be used in sequence programs.
📖 MP2000 Series User's Manual for Motion Programming (Manual No.: SIEP C880700 38)

Information The execution of a sequence program is completed in one scan.
Sequence programs are written using the same text-based language as motion programs.

Specifications

◆ Programs That Can Be Registered in the M-EXECUTOR

The following programs can be registered in the M-EXECUTOR:

Program Type		Number of Registered Programs
Motion programs		16*
Sequence programs	Startup	1
	Interrupt	Not possible
	H scan	16*
	L scan	16*

* Total: 16 programs

◆ Program Control Methods

You can use the following control methods for the programs that are registered in the M-EXECUTOR:

Item	Motion Programs	Sequence Programs
Execution method	Sequential execution	Startup: Event execution H scan: Scan execution L scan: Scan execution
System work	The same number is used for the definition number and system work number (the number of program definitions is set on the MPE720).	
Program designation method	Direct designation or indirect designation	Direct designation
Program execution method	Register the program in the definitions or turn ON the start signal.	Execution is started when the program is registered in the definitions.
Interpolation Override Setting	Supported.	Not supported.
I/O link definitions	Supported.	Not supported.
Motion program status reporting in S registers	Supported.	
Number of parallel forks	1 to 8 (main: 4 forks, sub: 2 forks)	1
Error diagram execution when an operation error occurs	Supported.	

Using the M-EXECUTOR

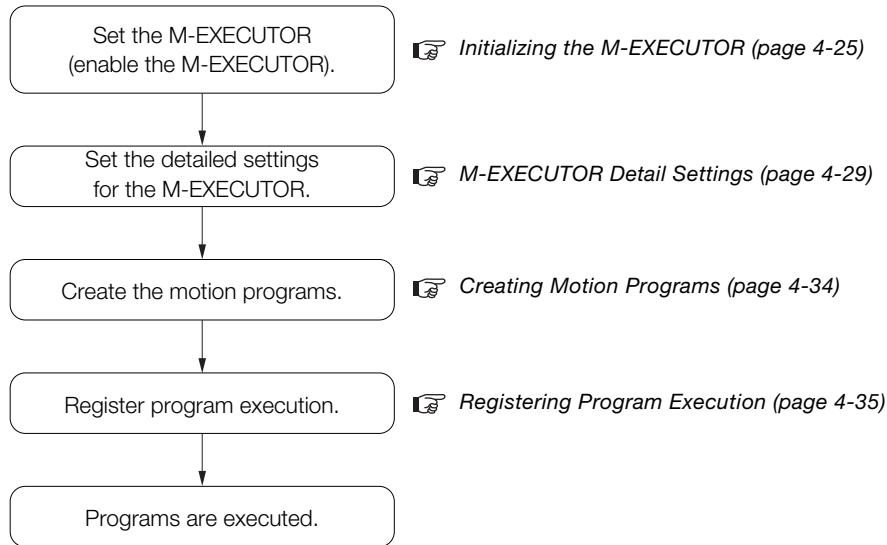

Initializing the M-EXECUTOR

Use the following procedure to initialize the M-EXECUTOR.

1. Click the **Module Configuration** Button on the My Tool View.

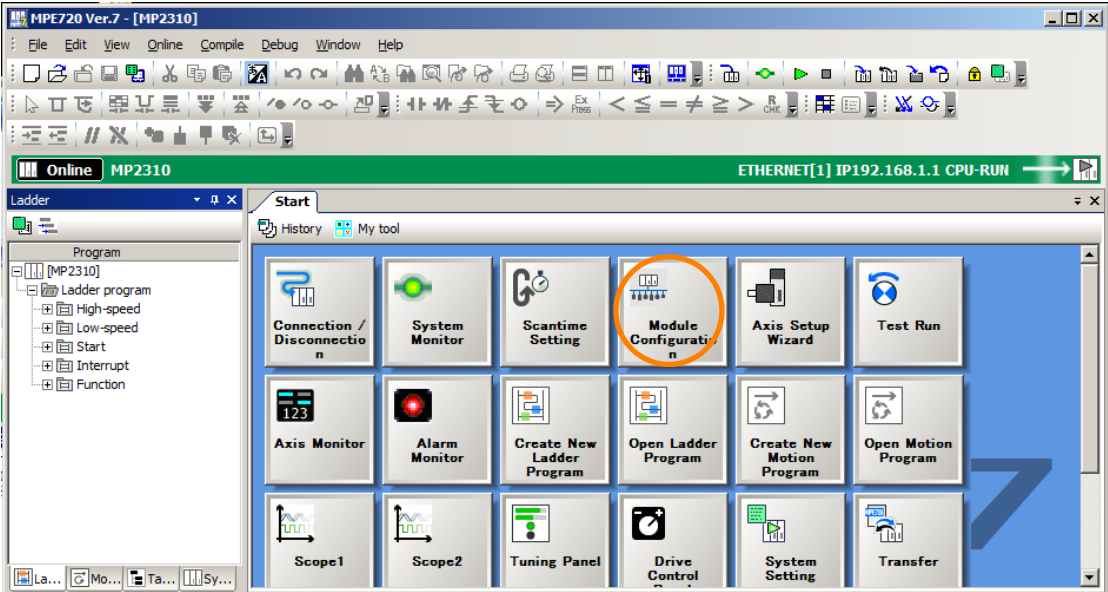

The Module Configuration Tab Page will be displayed.

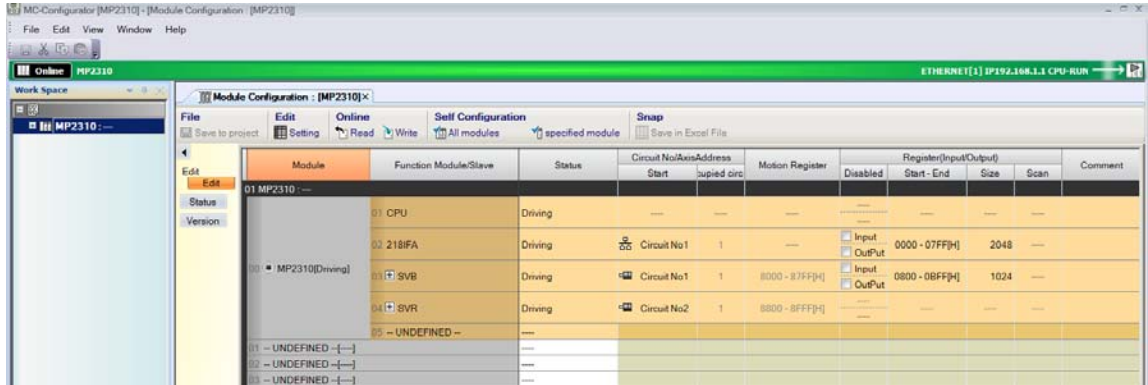

4.1 User Program Types and Execution Timing

4.1.4 The M-EXECUTOR

2. Double-click the **UNDEFINED** cell in row 05 of the **Function Module/Slave** Column.

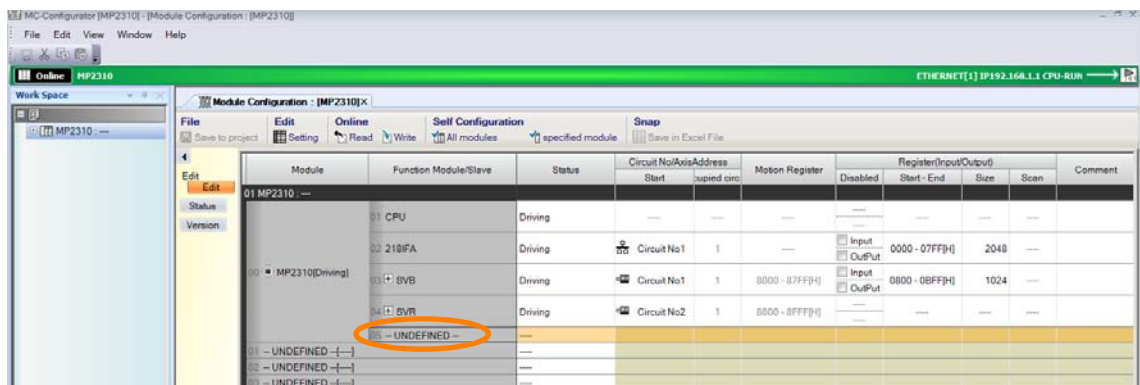

The Function Module Dialog Box will be displayed.

3. Select **M-EXECUTOR** and click the **OK** Button.

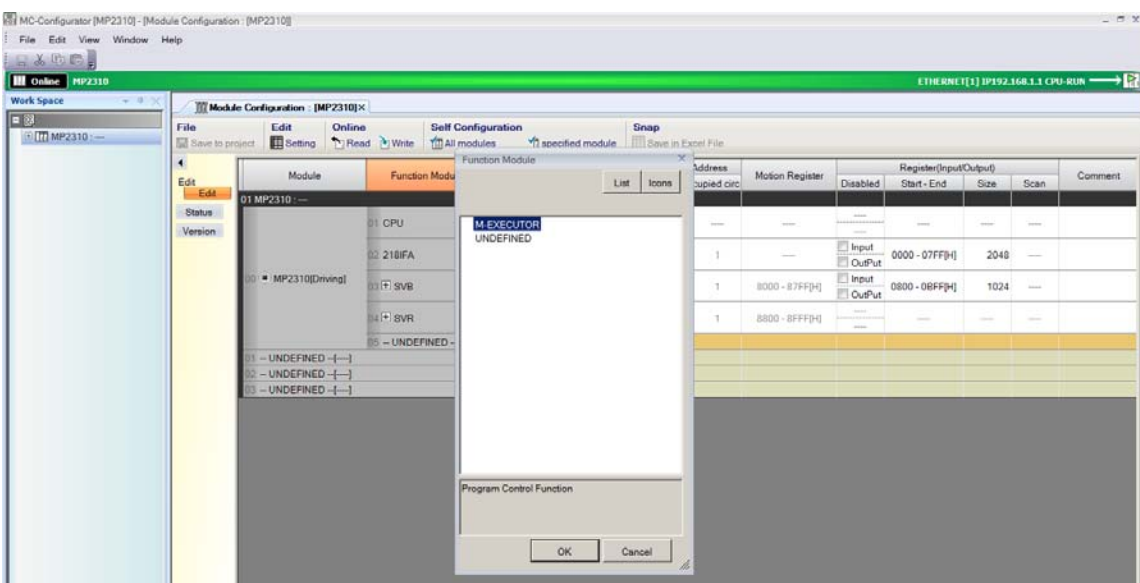

4. Verify that *M-EXECUTOR* is displayed in row 05, and double-click **M-EXECUTOR**.

Information If *M-EXECUTOR* is displayed, then the M-EXECUTOR is properly assigned.

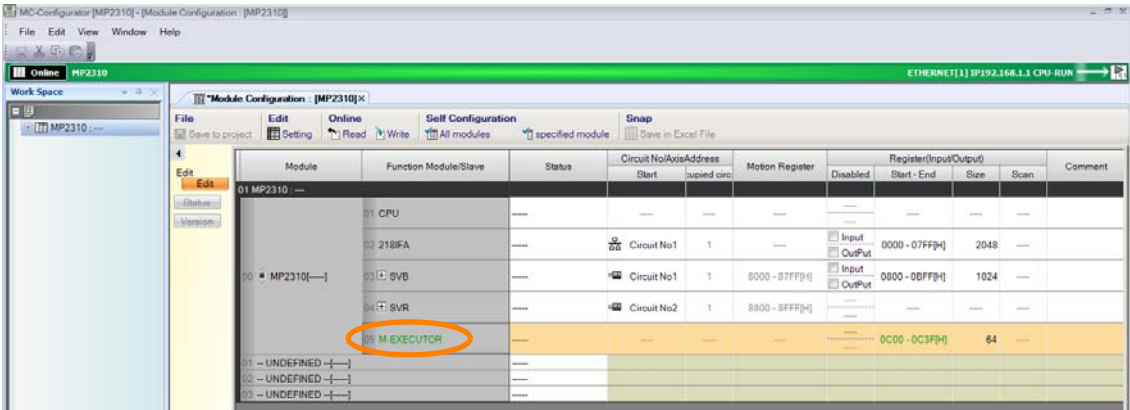

The M-EXECUTOR Definition Dialog Box will be displayed.

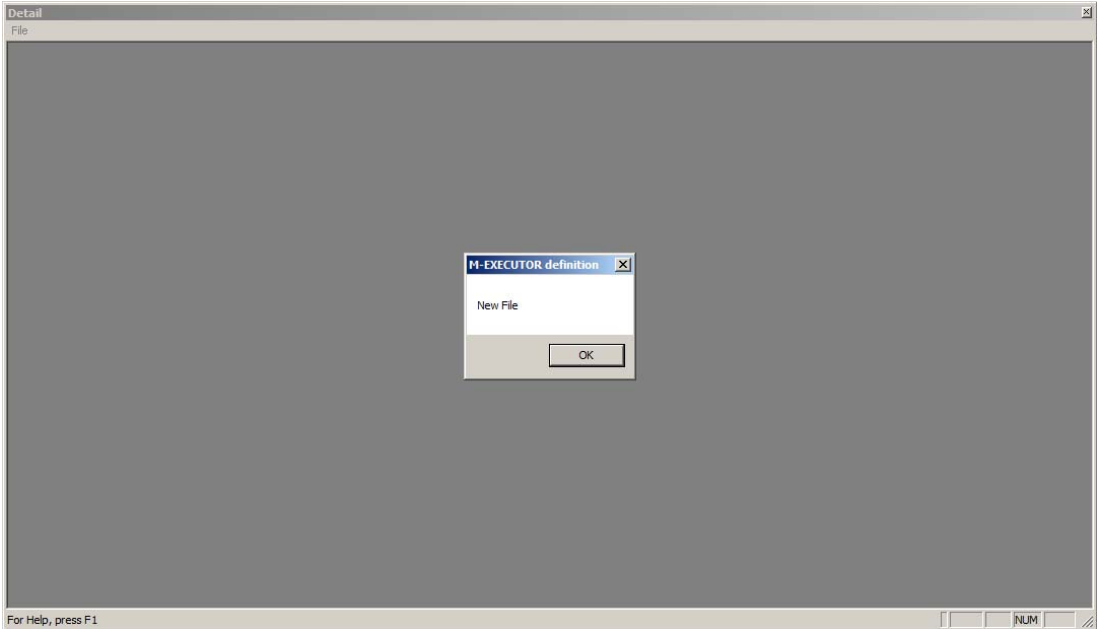

- Click the **OK** Button.
The Detail Definition Dialog Box will be displayed.

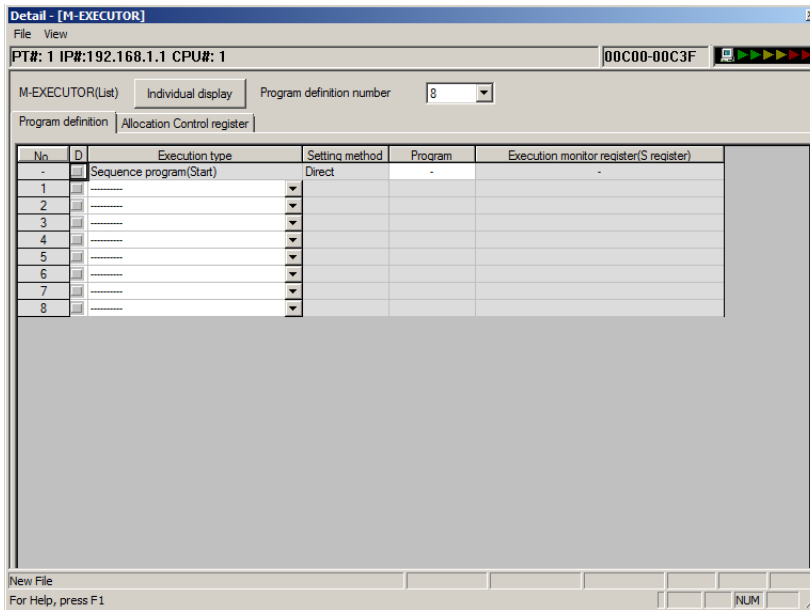

- Select **File - Save** from the toolbar.
The M-EXECUTOR definitions will be saved.
- Verify that *Driving* is displayed in the *Status* cell of the M-EXECUTOR row in the Module Configuration Tab Page.

Information If *Driving* is displayed, the M-EXECUTOR is enabled.

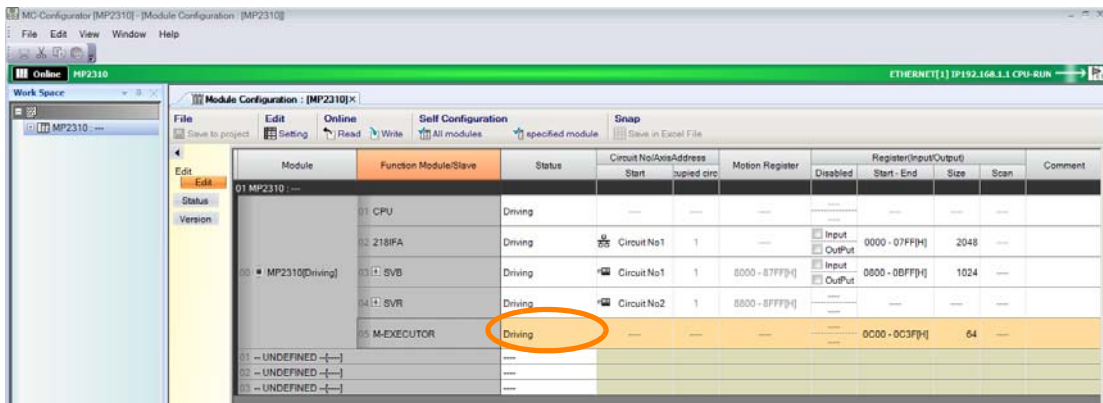

M-EXECUTOR Detail Settings

The detailed settings for the M-EXECUTOR are performed on the Module Configuration Tab Page and the Detail Definition Dialog Box.

This section provides the procedures to display this tab page and dialog box, and describes their contents.

◆ Module Configuration Tab Page

Use the following procedure to display the Module Configuration Tab Page.

- Click the **Module Configuration** Icon from the Start Tab Page.

The information on the M-EXECUTOR is displayed in row 05 of the *Function Module/Slave* Column.

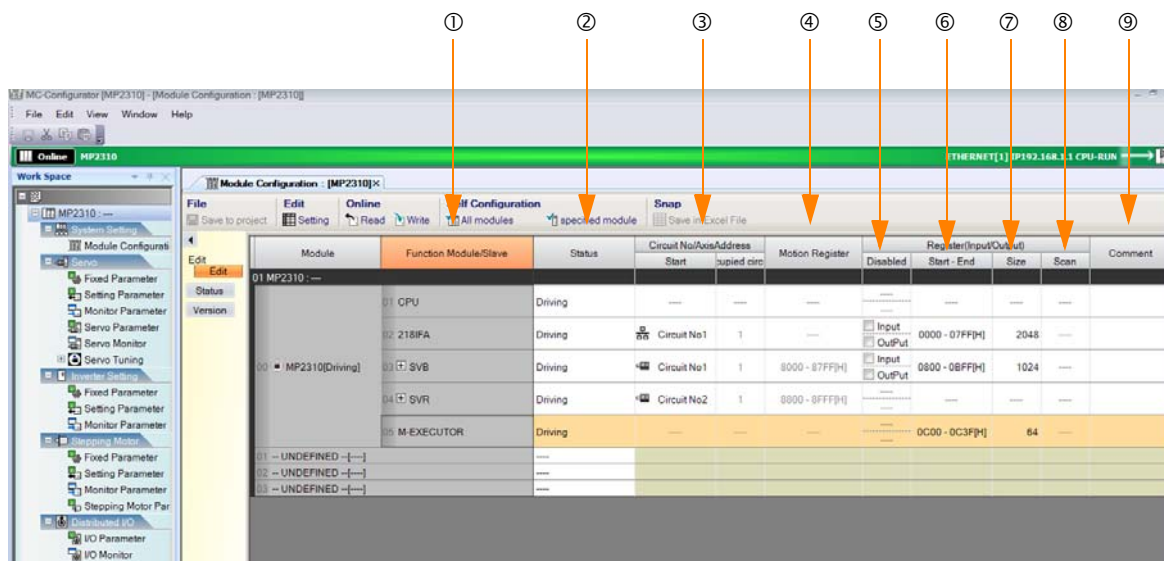

The following table describes the M-EXECUTOR items that are displayed on the Module Configuration Tab Page.

No.	Item	Display/Setting Item	Editing
①	Function Module/Slave	Displays whether the M-EXECUTOR is enabled. • UNDEFINED: Disabled • M-EXECUTOR: Enabled	Possible
②	Status	Displays the status of the M-EXECUTOR.	Possible
③	Circuit No./Axis Address	Not used. “----” is always displayed.	Not possible
④	Motion Register	Not used. “----” is always displayed.	Not possible
⑤		Disabled Not used. “----” is always displayed.	Not possible
⑥		Start - End Displays the range of registers that is used as the I/O area. • Setting range: 00000 to 07FFF hex Refer to the following section for details.  ◆ <i>Details on the I/O Registers on page 4-30</i>	Possible
⑦	Register (Input/Output)	Size Displays the number of words in the I/O area. • Setting range: 64 to 128 Four words each of input registers and output registers are required to register a single motion program or sequence program in the M-EXECUTOR. If you need to register more than 16 programs, set the size with four additional words for each program to add. A maximum of 32 programs can be registered (maximum number of program definitions).	Possible
⑧		Scan Not used. “----” is always displayed.	Not possible
⑨	Comment	Displays the user comment. Enter a comment of up to 16 characters.	Possible

◆ Details on the I/O Registers

The I/O registers that are assigned to the M-EXECUTOR are used to execute motion and sequence programs, as well as to monitor sequence programs.

The following tables give the contents of the M-EXECUTOR I/O registers.

M-EXECUTOR Input Registers			M-EXECUTOR Output Registers		
M-EXECUTOR Input Register	Item		M-EXECUTOR Output Register	Item	
IW□□□□ + 0	Definition No. 1	Status	OW□□□□ + 0	Definition No. 1	Program Number
IW□□□□ + 1		Reserved.	OW□□□□ + 1		Control Signals
IW□□□□ + 2		Reserved.	OW□□□□ + 2		Override
IW□□□□ + 3		Reserved.	OW□□□□ + 3		Reserved.
IW□□□□ + 4	Definition No. 2	Status	OW□□□□ + 4	Definition No. 2	Program Number
IW□□□□ + 5		Reserved.	OW□□□□ + 5		Control Signals
IW□□□□ + 6		Reserved.	OW□□□□ + 6		Override
IW□□□□ + 7		Reserved.	OW□□□□ + 7		Reserved.
⋮	⋮	⋮	⋮	⋮	⋮
IW□□□□ + 3C	Definition No. 16	Status	OW□□□□ + 3C	Definition No. 16	Program Number
IW□□□□ + 3D		Reserved.	OW□□□□ + 3D		Control Signals
IW□□□□ + 3E		Reserved.	OW□□□□ + 3E		Override
IW□□□□ + 3F		Reserved.	OW□□□□ + 3F		Reserved.

◆ Detail Definition Dialog Box

The Detail Definition Dialog Box has two tab pages, the Program Definition Tab Page and the Allocation Control Register Tab Page.

Use the following procedure to display the Detail Definition Dialog Box.

1. Click the **Module Configuration** Icon from the Start Tab Page.
2. Double-click row 05 of the *Function Module/Slave* Column.

■ Program Definition Tab Page

Register the motion or sequence programs to execute.

This section describes the items that are displayed on the Program Definition Tab Page.

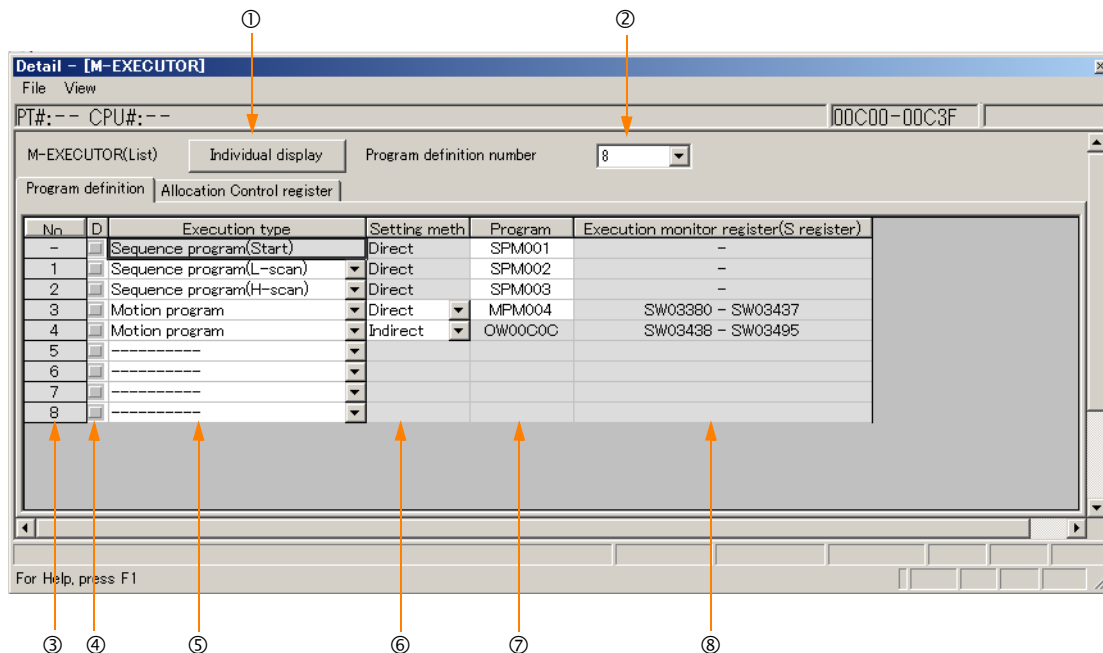

① Individual Display Button

Click this button to display the M-EXECUTOR in a separate window.

② Program Definition Number

Set the number of program definitions that can be registered in the M-EXECUTOR.

- Setting range: 0 to 32
- Default value: 8

③ No.

The execution order of the programs is displayed. Programs are executed in the scans in ascending order of their numbers.

④ D

Enable or disable the definitions.

- Not selected: Definition is enabled.
- Selected: Definition is disabled.

⑤ Execution Type

Set the execution type of the program.

Execution Type	Support Programs	Execution Condition
-----	Not supported.	–
Startup sequence program	Sequence programs	Startup (These programs are executed once when the power supply is turned ON.)
L-scan sequence programs		Started at a fixed interval. (These drawings are executed once every low-speed scan cycle.)
H-scan sequence programs		Started at a fixed interval. (These drawings are executed once every high-speed scan cycle.)
Motion programs	Motion programs	Request for Start of Program Operation control signal (The program is executed when the Request for Start of Program Operation is turned ON.)

⑥ **Setting**

Set the program designation method.

The designation method can be different for each program.

Designation Method	Motion Programs	Sequence Programs	Description
Direct designation	Supported.	Supported.	The program is specified with the program number. Examples: MPM001 or SPM002
Indirect designation	Supported.	Not supported.	The program is specified by specifying a register that contains the program number. Example: OW0C0C (If 1 is stored in OW0C0C, MPM001 will be called.)

⑦ **Program**

Set the program number.

Execution Type	Description
Sequence programs (Startup, L-scan, or H-scan)	If you enter 1 and press the Enter Key, SPM001 will be set automatically. You can specify a program that is not registered or leave the program number empty. In either case, no program will be executed.
Motion programs	Direct designation: If you enter 1 and press the Enter Key, MPM001 will be set automatically. You can specify a program that is not registered or leave the program number empty. In either case, no program will be executed. Indirect designation: The O register of the M-EXECUTOR Module will be set automatically. Only the system can set this.

⑧ **Execution Monitor Registers (S Registers)**

If the execution type is set to a motion program, the range of the execution monitor registers (S registers) will be displayed. Refer to the following manuals for details on the execution monitor registers.

 MP2000 Series User's Manual for Motion Programming (Manual No.: SIEP C880700 38)

■ Allocation Control Register Tab Page

This tab page is used to assign registers.

This section describes the items that are displayed on the Allocation Control Register Tab Page.

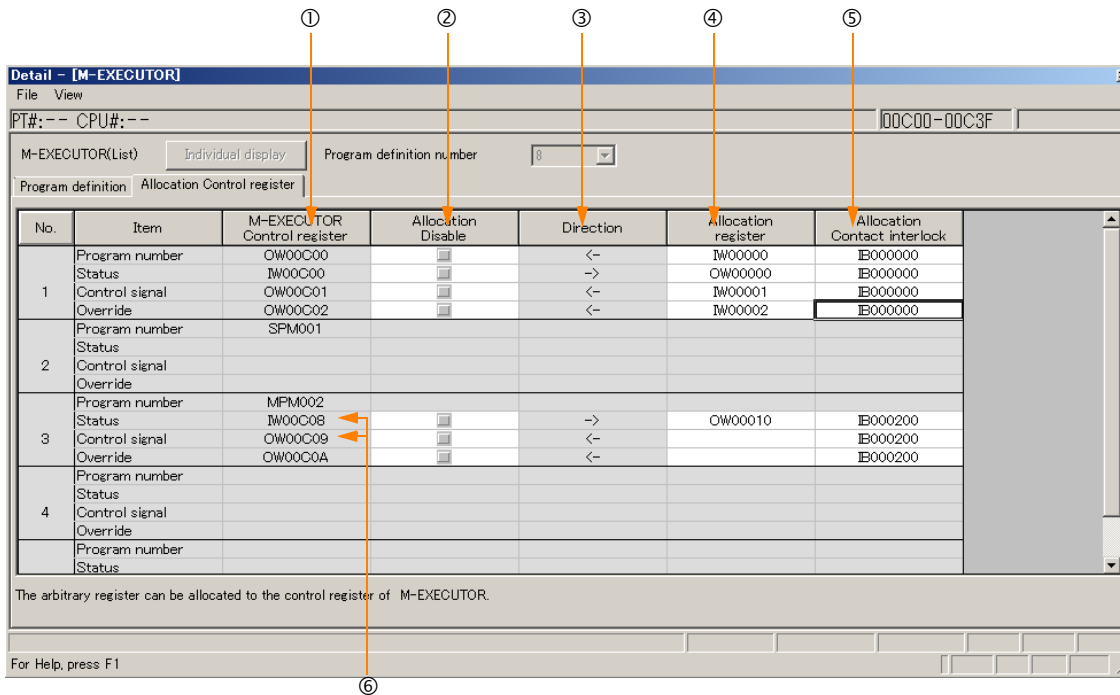

① M-EXECUTOR Control Register

This column displays the I/O registers that are assigned to the M-EXECUTOR. The M-EXECUTOR control registers are used to control or monitor the motion programs.

M-EXECUTOR Control Register	Application
Program Number	Sets the program number. This register is only used for indirect designation.
Status	Monitors the program execution status.
Control Signals	Controls the program.
Override	Sets the override value to use when executing interpolation motion instructions.

② Allocation Disable

Use these check boxes to enable or disable the assigned registers.

- Not selected: Definition is enabled.
- Selected: Definition is disabled.

③ Direction

This column displays the data I/O directions.

④ Allocation Register

The data of the assigned registers and the M-EXECUTOR control registers will move in the direction that is given in ③.

You can assign any register numbers.

Note: You can set word-type I, O, or M registers (except motion registers) in the Allocation register Column.

⑤ Allocation Contact Interlock

This contact controls the movement of data between the assigned registers and the M-EXECUTOR control registers. When the assigned interlock contact is ON, the data in the assigned registers and the M-EXECUTOR control registers will move in the direction that is given in ③.

Any register bit number can be assigned as the interlock contact.

Note: 1. You can set bit-type I, O, S, M, or C registers (except motion registers) in the Allocation Contact interlock Column.

- 2. The allocated interlock contact is used to interlock motion program operation. If you assign a register, always assign an interlock contact.

⑥ Status and Control Signal Details

Double-click the Status or the Control signal cell to display the Detail Dialog Box. This dialog box is used to verify the status and the control signals.

- Status

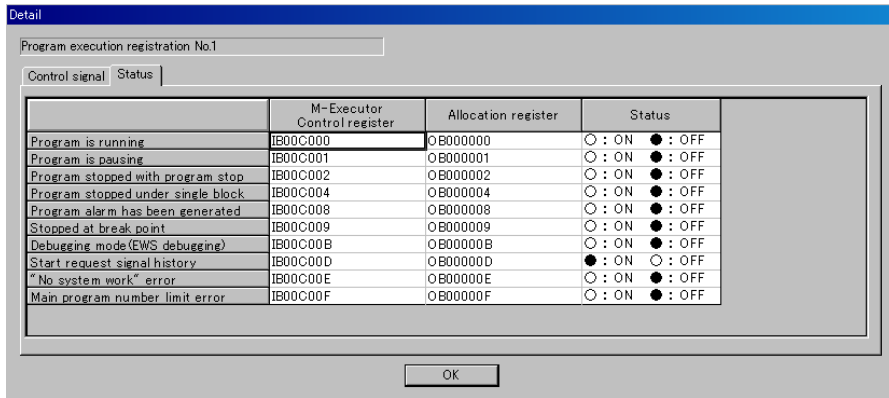

- Control Signals

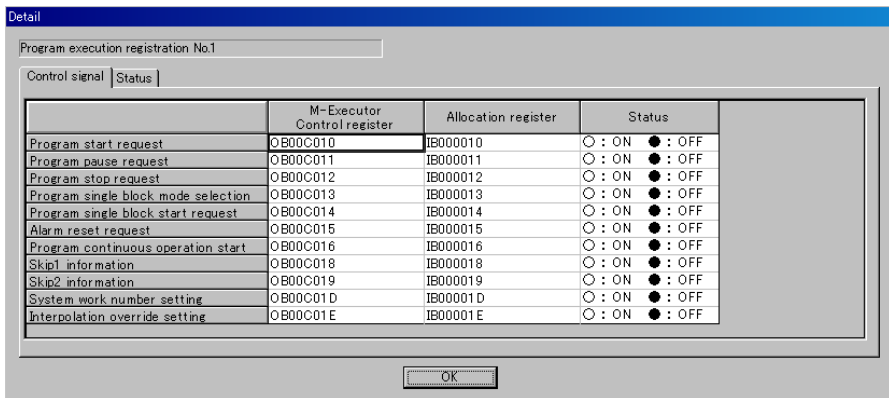

Creating Motion Programs

Refer to the following section and manual for details.

4.3 Creating Motion Programs on page 4-52

MP2000 Series User's Manual for Motion Programming (Manual No.: SIEP C880700 38)

Registering Program Execution

This section gives the procedure to register the execution of programs.

1. Display the program to register for execution.
2. Click the **Task Allocation** () Icon.

The Task Allocation Dialog Box will be displayed.

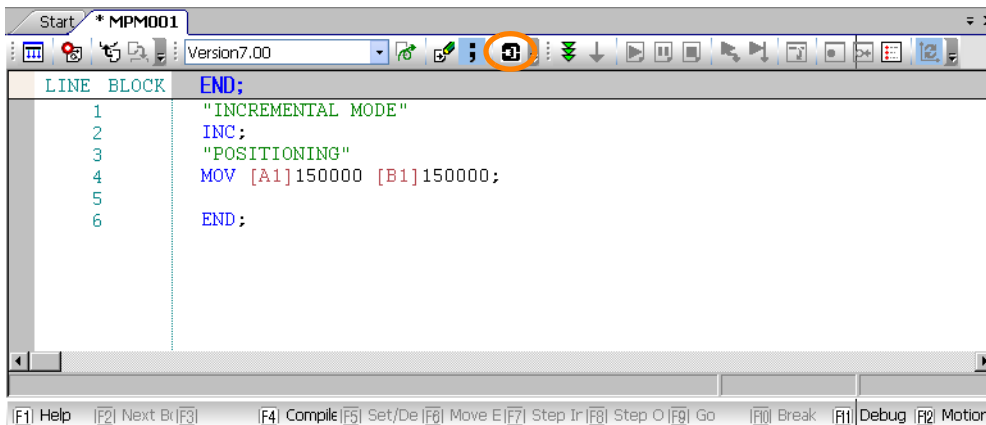

Information You can also use the Task Allocation Dialog Box to change the settings. Refer to the following manuals for details.
 MP2000 Series User's Manual for Motion Programming (Manual No.: SIEP C880700 38)

3. Check that the settings match the contents of the Allocation Control Register Tab Page, and then click the **Set** Button.
 The registered contents will be saved.

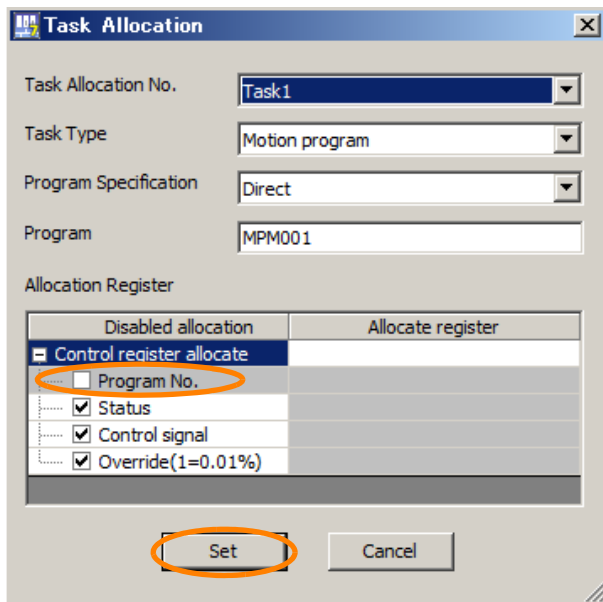

Refer to the following section for details on the Allocation Control Register Tab Page.
 **Allocation Control Register Tab Page** on page 4-33

Execution Scheduling

Programs that are registered in the M-EXECUTOR are executed in the order of their priority levels (execution types).

Programs that are registered in the M-EXECUTOR are executed immediately before processing the ladder programs.

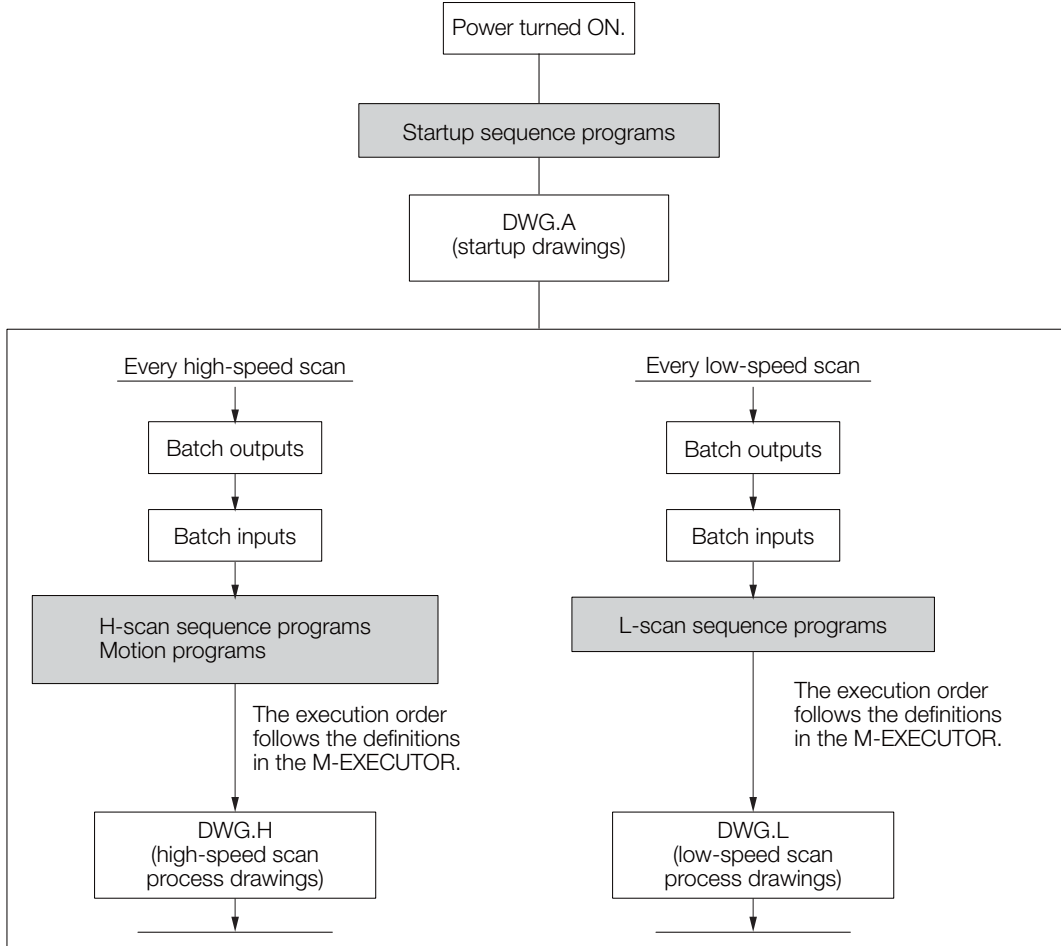

The following is an execution example.

- M-EXECUTOR Program Execution Definitions

Example Sequence Program Execution Example

The following figure shows an example of the sequence programs registered in the M-EXECUTOR.

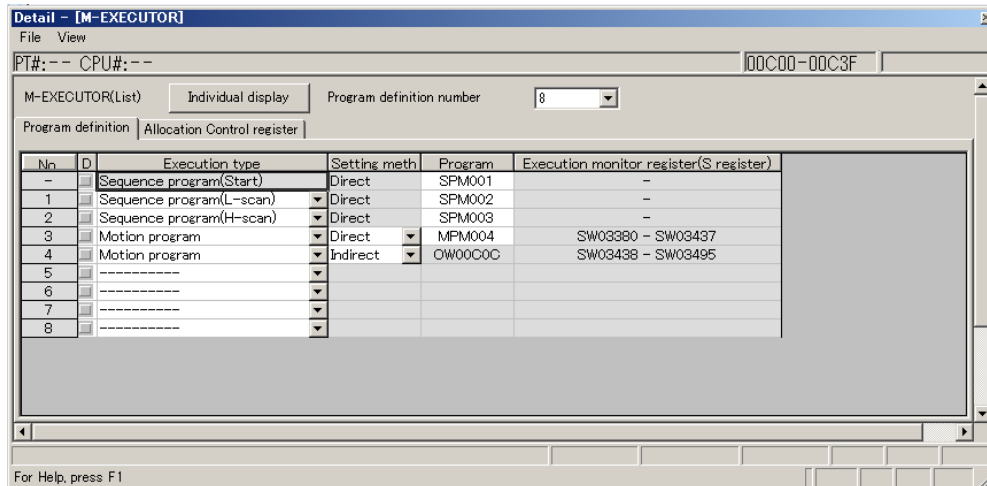

■ Execution Timing

This section describes the execution timing of programs in the above example. The following figure shows how program and drawing execution is based on the order of registration in the M-EXECUTOR program definitions.

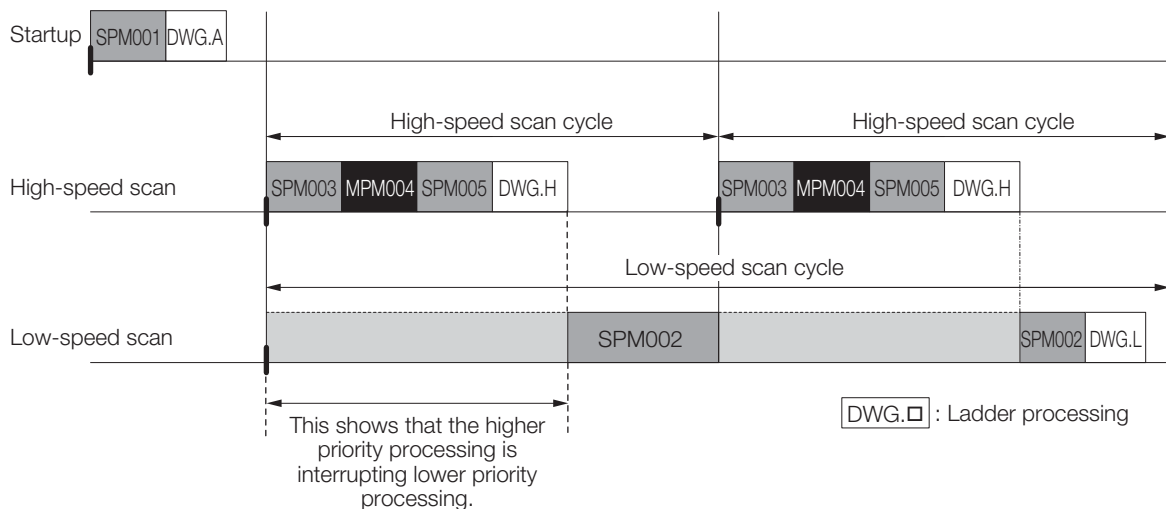

4.1.5 Registers

Registers are areas that store data within the Machine Controller. Variables are registers with labels (variable names).

There are two kinds of registers: global registers that are shared between all programs, and local registers that are used only by a specific program.

Global Registers

Global registers are shared by ladder programs, user functions, motion programs, and sequence programs. Memory space for global registers is reserved by the system for each register type.

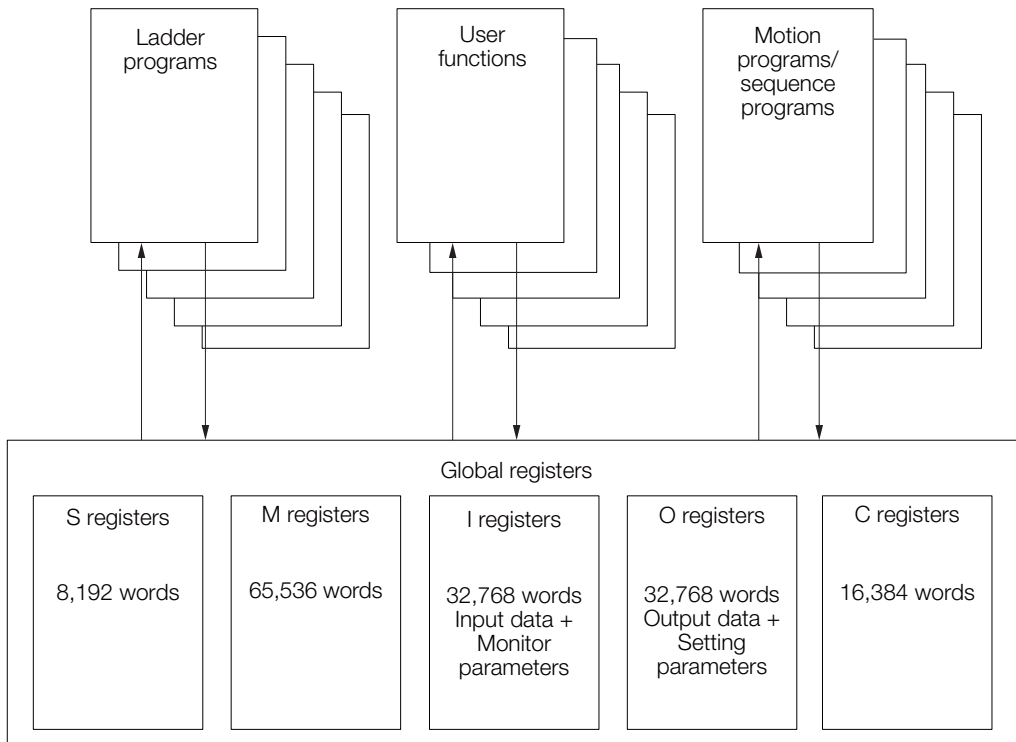

Local Registers

Local registers can be used within each specific drawing. These registers cannot be shared by other drawings. Local registers are stored in the program memory for each drawing.

Ladder Program Conceptual Diagram

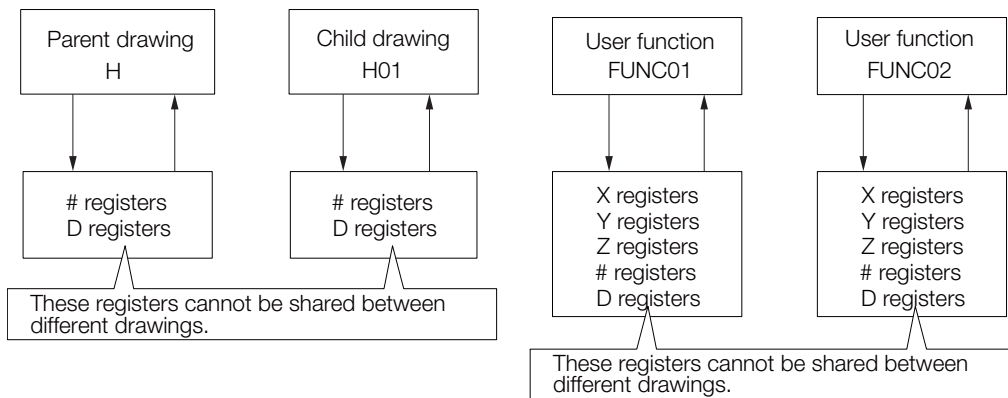

Motion Program Conceptual Diagram

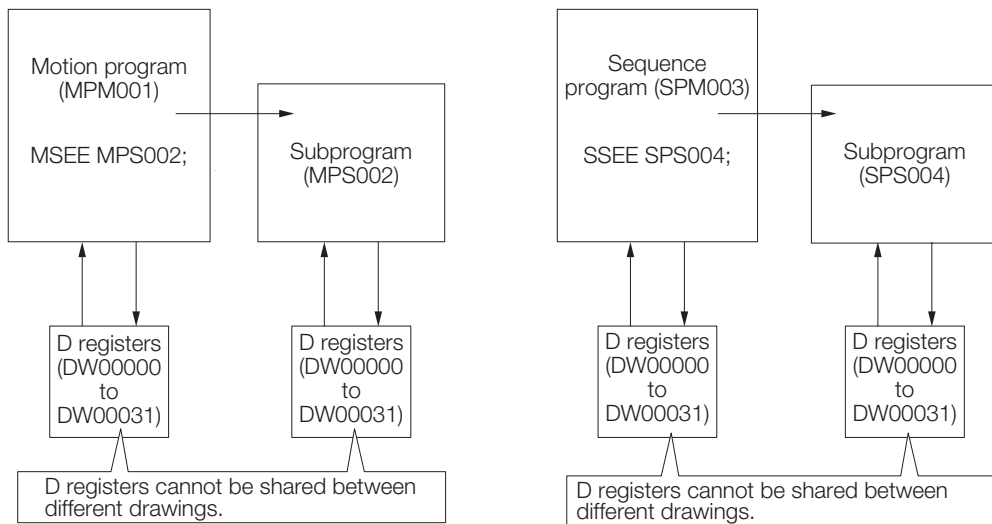

Structure of Register Addresses

Register address = S W 00000

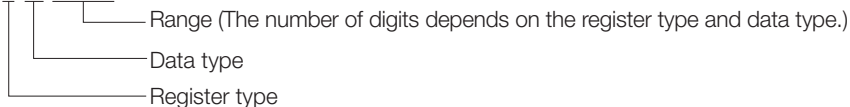

Information

You can also use index registers or array registers as variables to address specific registers. Refer to the following sections for details.

- ☞ *Index Registers (i, j)* (page 4-45)
- ☞ *Array Registers (I)* on page 4-46

Register Types

This section describes global and local registers.

◆ Global Registers

Global registers are shared by ladder programs, user functions, motion programs, and sequence programs. In other words, the operation results of a ladder program can be used by other user functions, motion programs, or sequence programs.

Type	Name	Designation Methods	Usable Range (MP3000-series Controller)	Description
S	System registers (S registers)	SBnnnnnh, SWnnnnn, SLnnnnn, SFnnnnn, SAnnnnn	SW00000 to SW8192	These registers are prepared by the system. They report the status of the Machine Controller and other information. The system clears the registers from SW00000 to SW00049 to 0 at startup. They have a battery backup.
M	Data registers (M registers)	MBnnnnnnnh, MWnnnnnnn, MLnnnnnnn, MFnnnnnnn, MAnnnnnnn	MW0000000 to MW65536	These registers are used as interfaces between programs. They have a battery backup.
I	Input registers (I registers)	IBhhhhhh, IWhhhhhh, ILhhhhhh, IFhhhhhh, IAhhhhhh	IW00000 to IW07FFF	These registers are used for input data.
			IW08000 to IW0FFFF	These registers store the motion monitor parameters. These registers are used for Motion Modules.
O	Output registers (O registers)	OBhhhhhh, OWhhhhhh, OLhhhhhh, OFhhhhhh, OAhhhhhh	OW00000 to OW07FFF	These registers are used for output data.
			OW08000 to OW0FFFF	These store the motion setting parameters. These registers are used for Motion Modules.
C	Constant registers (C registers)	CBnnnnnh, CWnnnnn, CLnnnnn, CFnnnnn, CAnnnnn	CW00000 to CW16383	These registers can be read in programs but they cannot be written. The values are set from the MPE720.

Note: n: decimal digit, h: hexadecimal digit

◆ Local Registers

Local registers are valid within only one specific program. The local registers in other programs cannot be accessed.

You specify the usable range from the MPE720.

Type	Name	Designation Methods	Description	Features
#	# registers	#Bnnnnnh, #Wnnnnn, #Lnnnnn, #Fnnnnn, #Annnnn	These registers can be read in programs but they cannot be written. The values are set from the MPE720.	Program-specific
D	D registers	DBnnnnnh, DWnnnnn, DLnnnnn, DFnnnnn, DAnnnnn	These registers can be used for general purposes within a program. By default, 32 words are reserved for each program. The default value after startup depends on the setting of the D Register Clear when Start option. Refer to the following section for details.  <i>Setting the D Register Clear When Start Option (page 4-42)</i>	

Continued on next page.

Continued from previous page.

Type	Name	Designation Methods	Description	Features
X	Function input registers	XBnnnnnh, XWnnnnn, XLnnnnn, XFnnnnn,	These registers are used for inputs to functions. <ul style="list-style-type: none"> • Bit inputs: XB000000 to XB00000F • Integer inputs: XW000001 to XW000016 • Double-length integers: XL000001 to XL000015 • Real numbers: XF000001 to XF000015 	Function-specific
Y	Function output registers	YBnnnnnh, YWnnnnn, YLnnnnn, YFnnnnn,	These registers are used for outputs from functions. <ul style="list-style-type: none"> • Bit outputs: YB000000 to YB00000F • Integer outputs: YW000001 to YW000016 • Double-length integers: YL000001 to YL000015 • Real numbers: YF000001 to YF000015 	
Z	Function internal registers	ZBnnnnnh, ZWnnnnn, ZLnnnnn, ZFnnnnn,	These are internal registers that are unique within each function. You can use them for internal processing in functions. <ul style="list-style-type: none"> • Bits: ZB000000 to ZB000063F • Integers: ZW000000 to ZW000063 • Double-length integers: ZL000000 to ZL000062 • Real numbers: ZF000000 to ZF000062 	
A	Function external registers	ABnnnnnh, AWnnnnn, ALnnnnn, AFnnnnn,	These are external registers that use the address input value as the base address. When the address input value of an M or D register is provided by the source of the function call, then the registers of the source of the function call can be accessed from inside the function by using that address as the base.	

Note: n: decimal digit, h: hexadecimal digit

◆ Local Registers within a User Function

In addition to # registers and D registers, there are local registers that can be used only within individual user functions.

Type	Name	Designation Methods	Description
X	Function input registers	XBnnnnnh, XWnnnnn, XLnnnnn, XFnnnnn,	These registers are used for inputs to functions. <ul style="list-style-type: none"> • Bit inputs: XB000000 to XB00000F • Integer inputs: XW000001 to XW000016 • Double-length integers: XL000001 to XL000015 • Real numbers: XF000001 to XF000015
Y	Function output registers	YBnnnnnh, YWnnnnn, YLnnnnn, YFnnnnn,	These registers are used for outputs from functions. <ul style="list-style-type: none"> • Bit outputs: YB000000 to YB00000F • Integer outputs: YW000001 to YW000016 • Double-length integers: YL000001 to YL000015 • Real numbers: YF000001 to YF000015
Z	Function internal registers	ZBnnnnnh, ZWnnnnn, ZLnnnnn, ZFnnnnn,	These are internal registers that are unique within each function. You can use them for internal processing in functions.
A	Function external registers	ABnnnnnh, AWnnnnn, ALnnnnn, AFnnnnn,	These are external registers that use the address input value as the base address. When the address input value of an M or D register is provided by the source of the function call, then the registers of the source of the function call can be accessed from inside the function by using that address as the base.

Note: n: decimal digit, h: hexadecimal digit



Important

User functions can be called from any programs, any number of times.

■ Precautions When Using Local Registers within a User Function

When you call a user function, consider what values could be in the local registers, and perform initialization as needed.

Name	Precautions
X registers (function input registers)	If input values are not set, the values will be uncertain. Do not use X registers that are outside of the range that is specified in the input definitions.
Y registers (function output registers)	If output values are not set, the values will be uncertain. Always set the values of the range of Y registers that is specified in the output definitions.
Z registers (function internal registers)	When the function is called, the previously set values will be lost and the values will be uncertain. These registers are not appropriate for instructions if the previous value must be retained. Use them only after initializing them within the function.
# registers	These are constant registers. Their values cannot be changed.
D registers	When the function is called, the previously set values are preserved. If a previous value is not necessary, initialize the value, or use a Z register instead. D registers retain the data until the power is turned OFF. The default value after startup depends on the setting of the D Register Clear when Start option. Refer to the following section for details.  <i>Setting the D Register Clear When Start Option (page 4-42)</i>

• Setting the D Register Clear When Start Option

1. Select **File - Environment Setting** from the MPE720 Version 7 Window.
2. Select **Setup - System Setting**.
3. Select **Enable** or **Disable** for the **D Register Clear when Start** option.
 Disable: The initial values will be uncertain.
 Enable: The initial values will be 0.

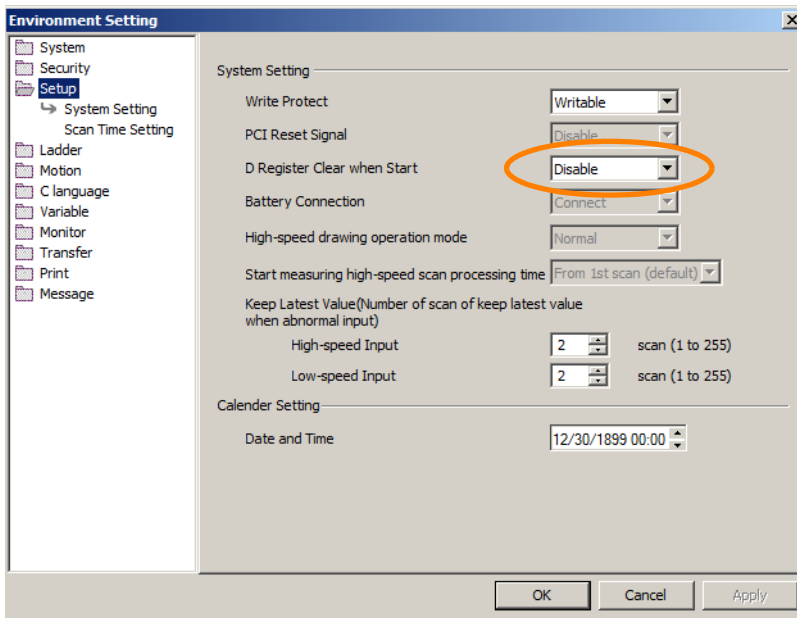

Data Types

There are different data types that you can use depending on the purpose of the application: bit, integer, double-length integer, real number, and address.

Symbol	Data Type	Range of Values	Data Size	Description
B	Bit	1 (ON) or 0 (OFF)	–	Used in relay circuits and to determine ON/OFF status.
W	Integer	-32,768 to 32,767 (8000 to 7FFF hex)	1 word	Used for numeric operations. The values in parentheses on the left are for logical operations.
L	Double-length integer	-2,147,483,648 to 2,147,483,647 (80000000 to 7FFFFFFF hex)	2 words	Used for numeric operations. The values in parentheses on the left are for logical operations.
F	Real number	± (1.175E-38 to 3.402E+38) or 0	2 words	Used for advanced numeric operations.*
A	Address	0 to 32,767	–	Used only as pointers for addressing.

* Conforms to IEEE754 standards.



Important The MP2000-series Machine Controller does not have separate registers for each data type. As shown in the following figure, the same address will access the same register even if the data type is different. For example, MB001003, a bit address, and the MW00100, an integer address, have different data types, but they both access the same register, MW00100.

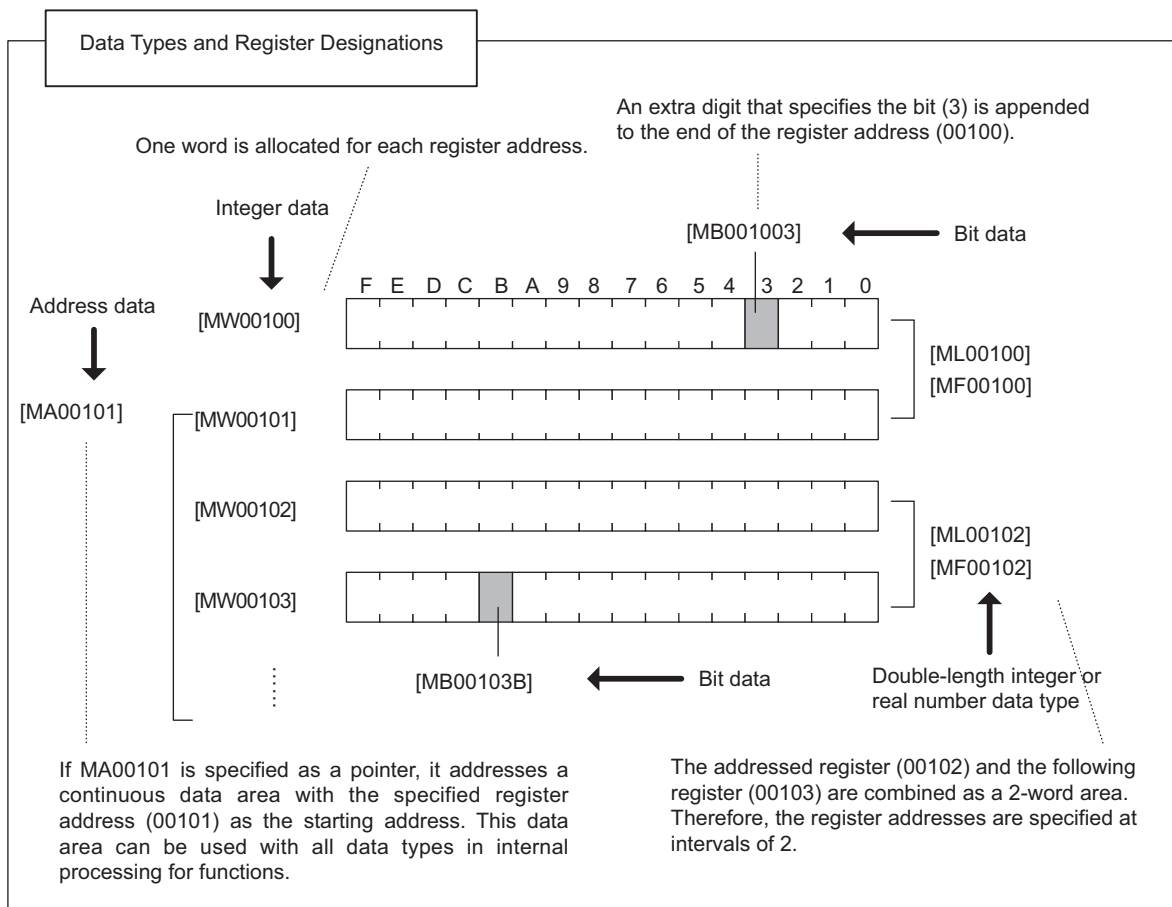



Term **Pointer Designation** When an address is passed to a function as a parameter, this is referred to as pointer designation. When pointer designation is used, the continuous data area starting from the address of the specified register number can be used in internal processing for functions with all data types.

◆ Precautions for Operations Using Different Data Types

If you perform an operation using different data types, be aware that the results will be different depending on the data type of the storage register, as described below.

• Storing Real Number Data in an Integer Register

MW00100 = MF00200; the real number is stored after it is converted to an integer.
(00001) (1.234)

Note: There may be rounding error due to storing a real number in an integer register. Whether numbers are rounded or truncated when converting a real number to an integer can be set in the properties of the drawing.

■ Setting for Real Number Casting on page 4-44

MW00100 = MF00200 + MF00202

(0124) (123.48) (0.02) The result of the operation may be different depending on the value of the variable.

(0123) (123.49) (0.01)

• Storing Real Number Data in a Double-length Integer Register

ML00100 = MF00200; the real number is stored after it is converted to an integer.
(65432) (65432.1)

• Storing Double-length Integer Data in an Integer Register

MW00100 = ML00200; the lower 16 bits of the double-length integer are stored without change.

(-00001) (65535)

• Storing Integer Data in a Double-length Integer Register

ML00100 = MW00200; the integer is stored after it is converted to double-length integer data.
(0001234) (1234)

■ Setting for Real Number Casting

The casting method (truncating or rounding) can be set in the detailed definitions in the Program Property Dialog Box.

The method to use for real number casting is set for each drawing.

Use the following procedure to display the Program Property Dialog Box.

1. In the Ladder Pane, select the ladder program for which to view the properties.
2. Right-click the selected program and select **Property** from the pop-up menu. The Program Property Dialog Box will be displayed.

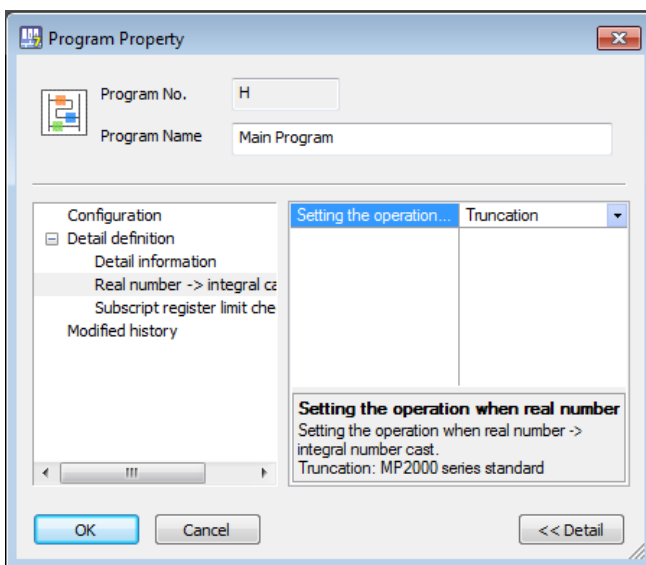

Information The data is little endian, as shown in the following example.

- MB001006

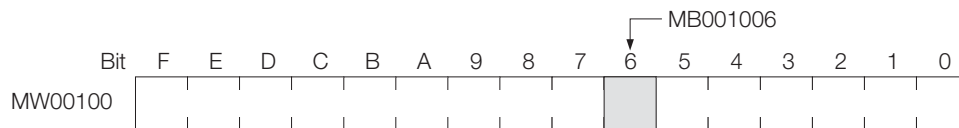

- MW00100 = 1234 hex



- ML00100 = 12345678 hex



Index Registers (i, j)

There are two special registers, *i* and *j*, that are used to modify relay and register addresses. The functions of *i* and *j* are identical. They are used to handle register addresses in registers.

The indices *i* and *j* can be expressed in decimal when specified as variables.

We will describe this with examples for each register data type.

■ Attaching an Index to a Bit Register

Using an index is the same as adding the value of *i* or *j* to the register address.

For example, if *i* = 2, MB000000*i* is the same as MB000002.

i = 2;
 DB000000 = MB000000*i*; Equivalent DB000000 = MB000002;

■ Attaching an Index to an Integer Register

Using an index is the same as adding the value of *i* or *j* to the register address.

For example, if *j* = 30, MW000001*j* is the same as MW000031.

j = 30;
 DW000000 = MW000001*j*; Equivalent DW000000 = MW000031;

■ **Attaching an Index to a Double-length Integer or a Real Number Register**

Using an index is the same as adding the value of i or j to the register address.

For example, if j = 1, ML00000j is the same as ML00001. Similarly, if j = 1, MF00000j is the same as MF00001.

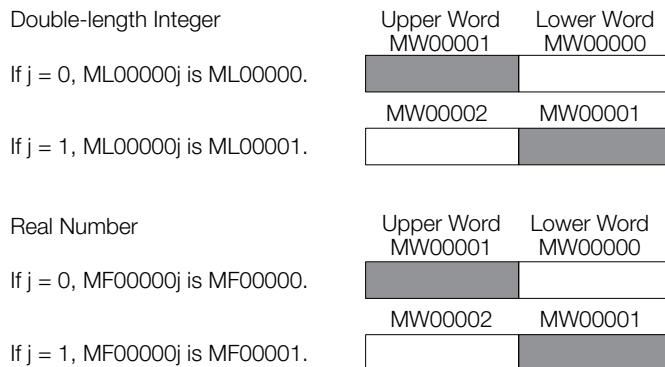

Information Double-length integers and real numbers use a region that is 2 words in size. For example, when using ML00000j with both j = 0 and j = 1, the one-word area of MW00001 will overlap. Be careful of overlapping areas when indexing double-length integer or real number register addresses.

Array Registers ([])

Array registers are used to modify register addresses.

They are used to handle register addresses as variables.

As with indices, an offset can be added to the register address.

◆ **Attaching an Array Register to a Bit Register**

Using an array register is the same as adding the value of the array register to the register address.

For example, if DW00000 = 2, MB000000[DW00000] is the same as MB000002.

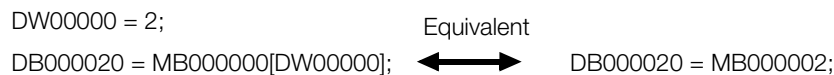

◆ **Attaching an Array Register to a Register Other Than a Bit Register**

Using an array register is the same as adding the word size of the data type of the array register times the value of the array register to the register address.

For example, if DW00000 = 30, ML00002[DW00000] is the same as ML000062.

DL00002 = ML00000 (30 × 2 + 2) = ML000062

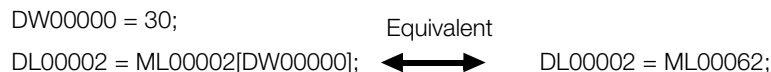

◆ Format

This section describes the formats of array registers.

```
MOV[A1]ML00000[MW00100];
      ①          ②
```

Contents	Use	Usable Registers
①	Array name	All registers with any data type (excluding # and C registers)
②	Array elements	<ul style="list-style-type: none"> • All registers with integer and double-length integer data types (excluding # and C registers) • Constants • Index registers

◆ Programming Example

In the following example, an array register is used to calculate the total amount of 50 registers from ML0000100 to ML0000198. That amount is then stored in ML0000200.

```
ML0000200 = 0;
DW00000 = 0;
WHILE DW00000 < 50;
  ML0000200 = ML0000200 + ML0000100[DW00000];
  DW00000 = DW00000 + 1;
WEND;

END;
```

4.2 Creating Ladder Programs

Use the following procedure to create a ladder program.

Information The following example shows how to create a high-speed program, but low-speed and startup programs can be created in essentially the same way.

1. Select **Programming - Ladder program** in the Launcher. The Ladder Pane will be displayed.
2. Right-click **High-speed** under **Ladder program**, and select **New**.

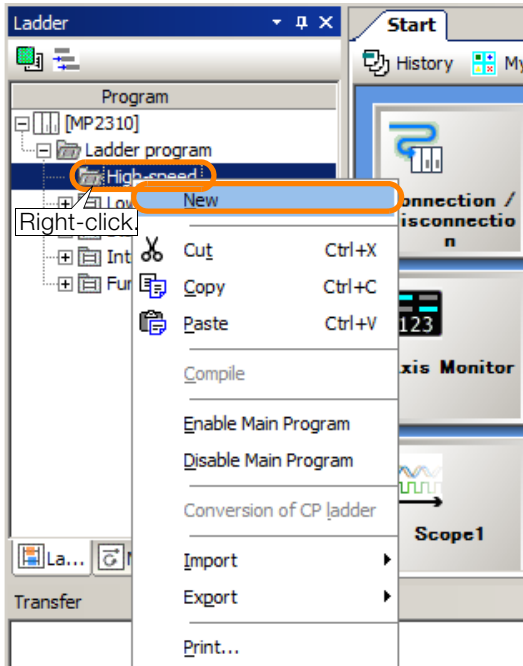

The Create New Program Dialog Box will be displayed.

3. Click the **OK** Button.

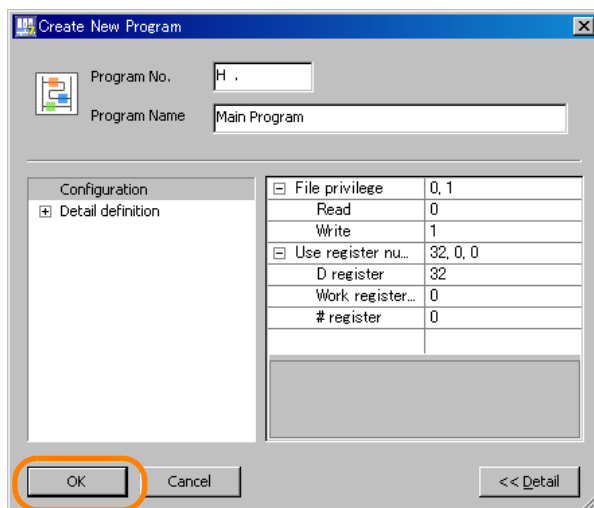

The Ladder Editor will start.

4. Enter the ladder program.

Ladder programs are entered by inserting rungs, then instructions, and finally parameters for the instructions. Refer to the following section for details.

 *Ladder Program Creation Example (page 4-49)*

5. While displaying the ladder program, select **Compile** – **Compile** from the menu bar to compile the program.

When the compilation is finished, the ladder program will be saved automatically.



Important

If an error is displayed in the Output Pane during compilation, the ladder program will not be saved.

Ladder Program Creation Example

The following example shows how to insert an NO Contact instruction.

1. Right-click the tab with the row number, and select **Insert Rung**.

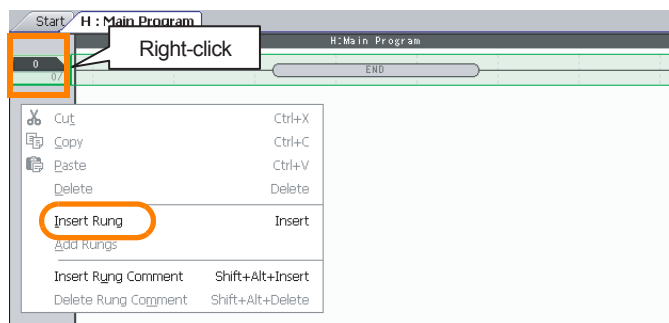

A rung will be inserted.

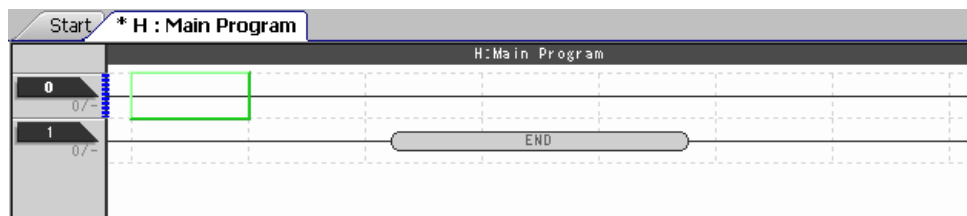

2. Create an NO Contact instruction with one of the following methods.

- Drag NO Contact under RELAY in the Task Pane.

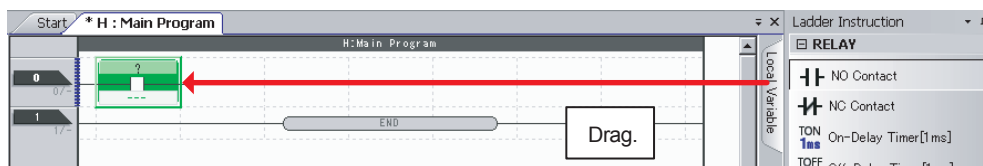

- Double-click at the location at which to insert the NO Contact instruction, and select A: NO Contact from the list.

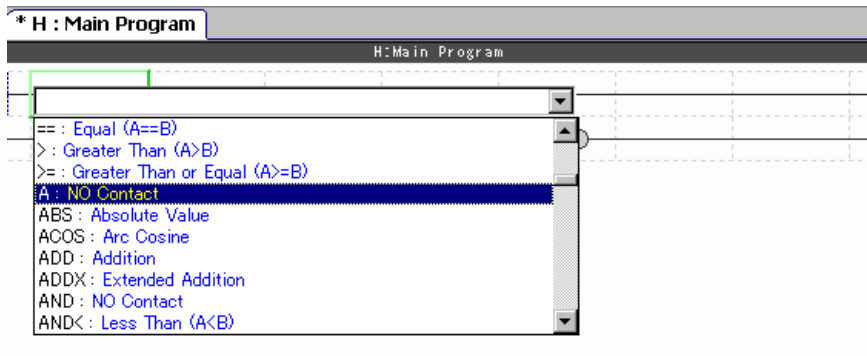

- Select the location at which to insert the NO Contact instruction, and click the NO Contact Button.

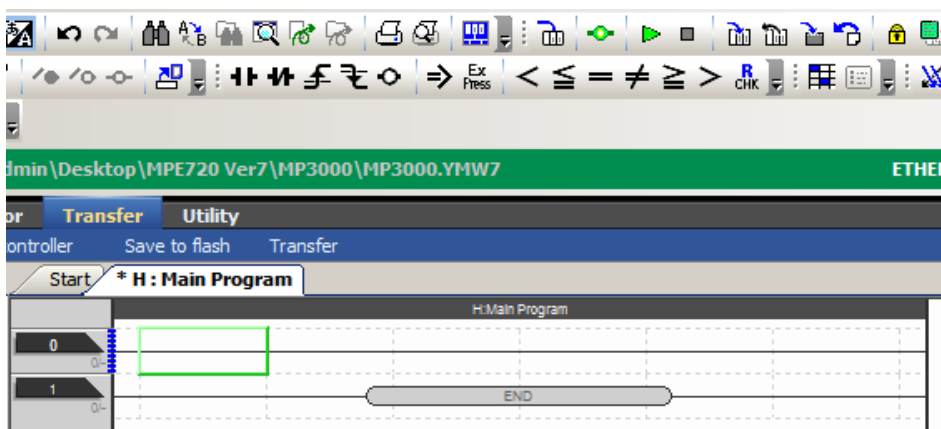

3. Double-click the box with a question mark.

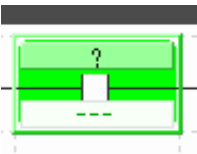

The Edit Parameter Dialog Box will be displayed.

4. Enter **MB000000** in the **Variable/Register** Box and click the **OK** Button.

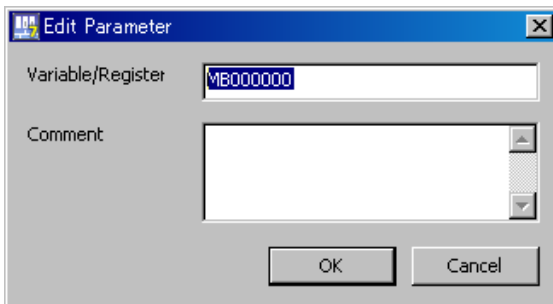

MB000000 will be displayed for the NO Contact instruction.



Note: The type of register and data you can use depend on the actual instruction. Refer to the following manual for details on each instruction.

MP900/MP2000 Series User's Manual Ladder Programming (Manual No.: SIEZ-C887-1.2)

Information To insert a comment, right-click the tab with the row number, and select *Insert Rung Comment*.

- Repeat steps 1 to 4 until you have entered the entire ladder program. The following example shows a ladder program and its timing chart.

<Ladder Program Example>

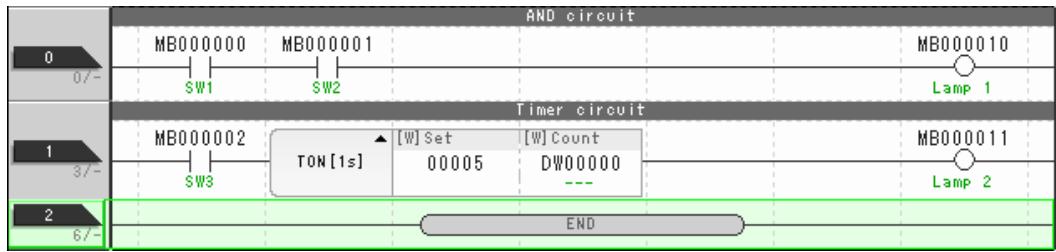

Note: The ladder program example that is shown above uses M registers for switches and lamps. When you enter a ladder program for an actual system, use the appropriate I and O registers.

<Timing Chart Example>

AND Circuit Operation

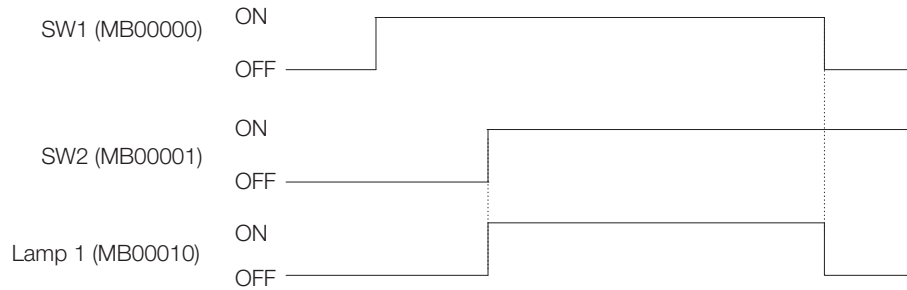

Timer Circuit Operation

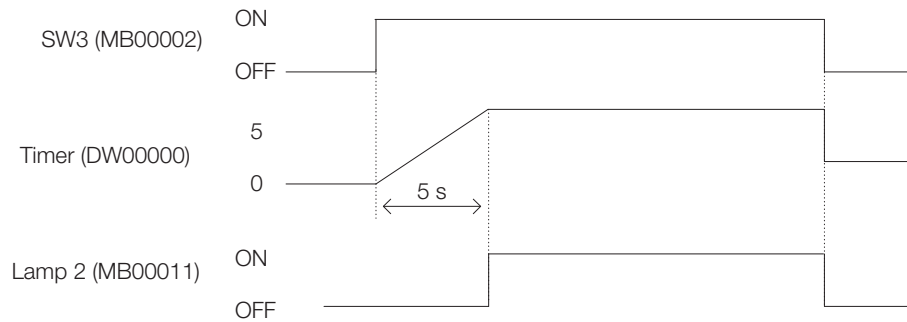

4.3 Creating Motion Programs

This section describes how to create motion main programs and motion subprograms.

4.3.1 Creating a Group Definition

Before creating a motion program, we have to group the axes together as required by the machine configuration.

1. Click the **Motion** Tab in the Programming Pane to display **Motion program** in the Motion Pane.

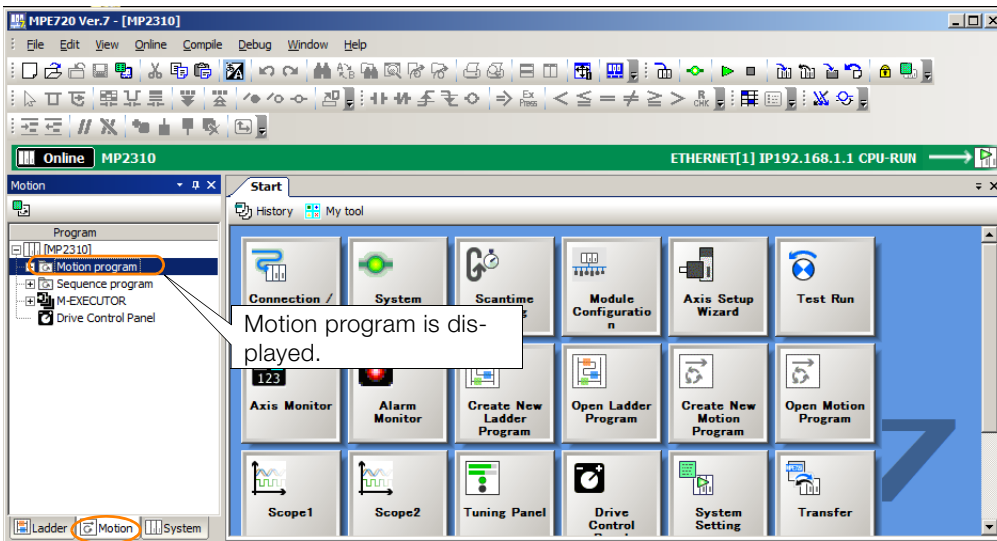

2. Right-click **Motion program**, and select **Group Definition**.

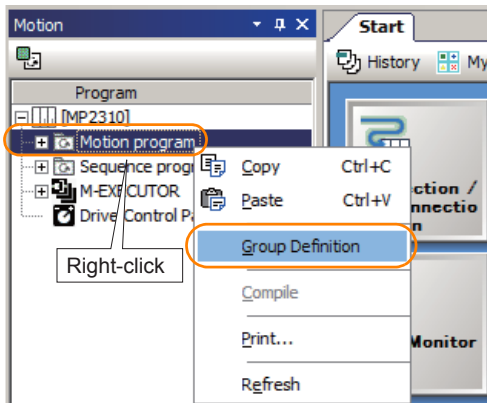

3. Click the **OK** Button.

Refer to the following manuals for details on group definitions.

 MP2000 Series User's Manual for Motion Programming (Manual No.: SIEP C880700 38)

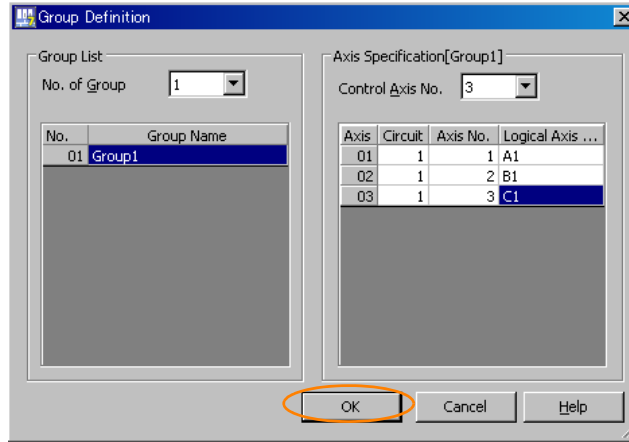

4.3.2 Creating a Motion Main Program

Use the following procedure to create a motion main program.

1. Start the Motion Editor.
2. Expand the tree structure in the Motion Pane. Right-click **Main program** and select **New**.

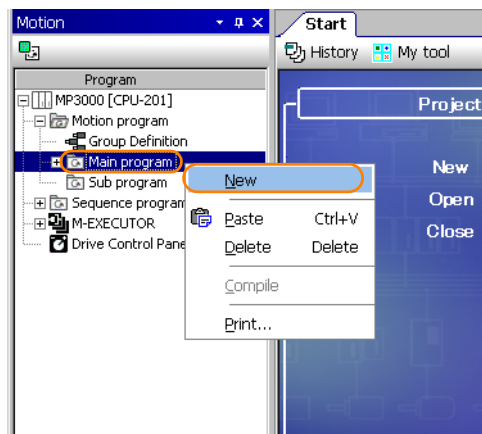

3. Click the **OK** Button.

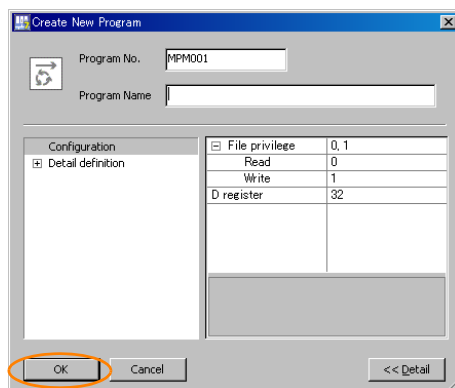

4. Edit the motion program.

Use the instruction input assistance feature to insert an INC instruction and a MOV instruction into the motion program.

The motion instruction assistance feature is used by right-clicking on the Motion Editor Tab Page.

- Calling the Instruction Input Assistance Feature (Select *Motion Command Assist.*)

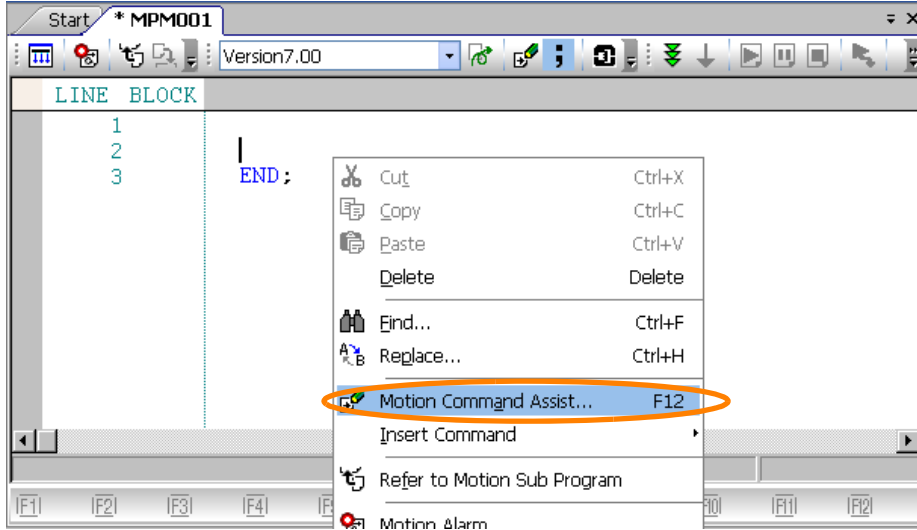

- Inserting an INC Instruction

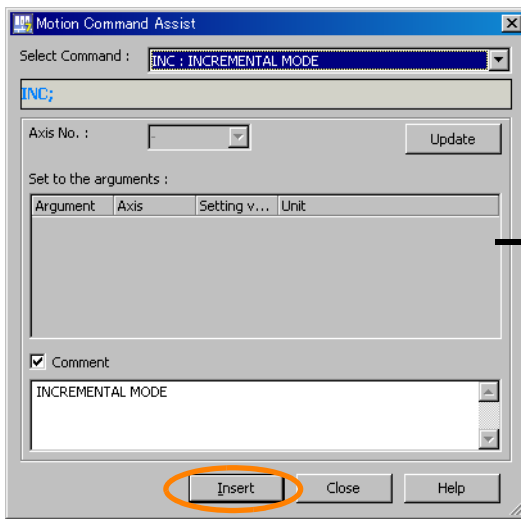

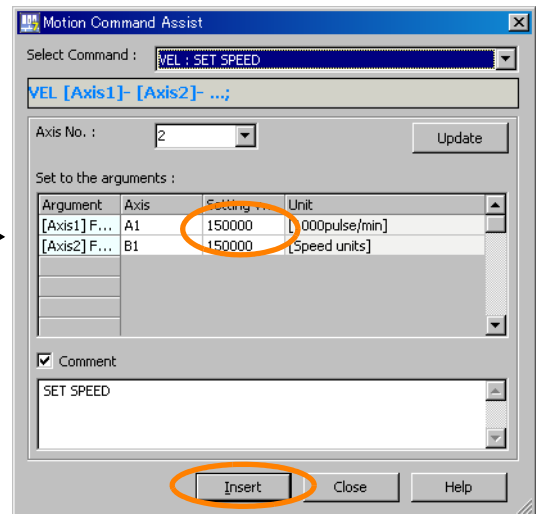

- Inserting a MOV Instruction

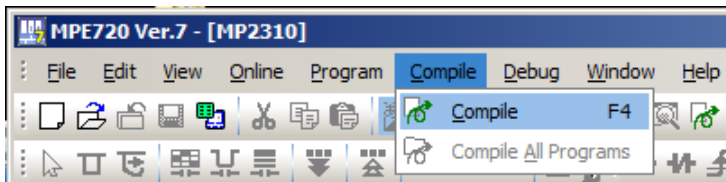

5. Select **Compile - Compile** from the menu bar to compile the program.

When the compilation is finished, the motion program will be saved automatically.





Important If an error occurs during compilation, the motion program will not be saved.

4.3.3 Creating a Motion Subprogram

Use the following procedure to create a motion subprogram.

1. Start the Motion Editor.
2. Expand the tree structure in the Motion Pane. Right-click **Sub program**, and select **New**.

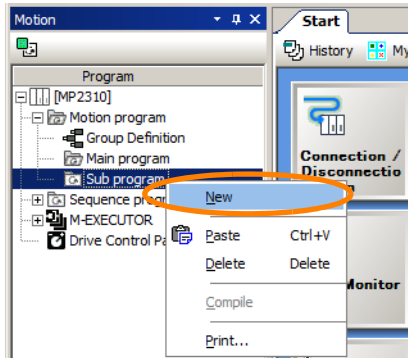

3. Click the **OK** Button.

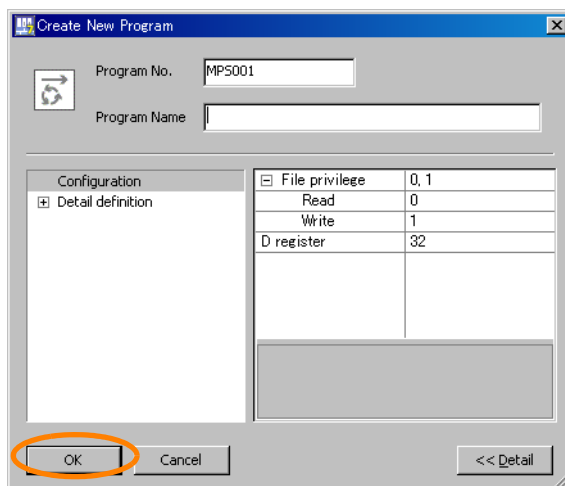

4. Enter the motion program.

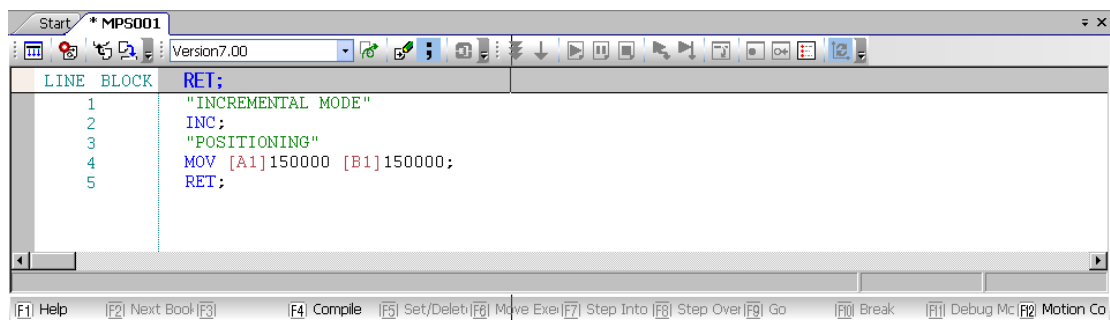

5. Select **Compile - Compile** from the menu bar to compile the program.
When the compilation is completed, the motion program is saved automatically.

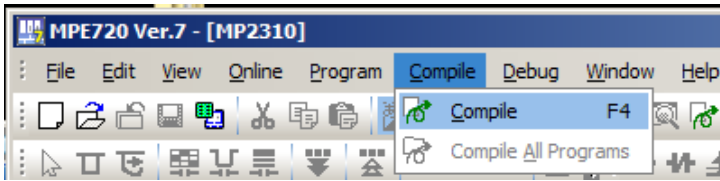

Important

If an error was displayed in the Error List Dialog Box during compilation, the motion program will not be saved.

4.4 Creating a Sequence Program

This section describes how to create sequence main programs and sequence subprograms.

4.4.1 Creating a Sequence Main Program

Use the following procedure to create a sequence main program.

1. Start the Motion Editor.
2. Expand the tree structure in the Motion Pane. Right-click **Main program** and select **New**.

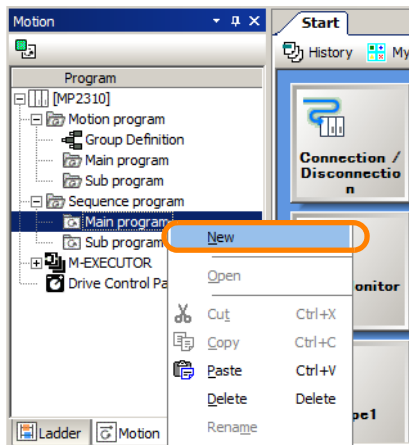

3. Click the **OK** Button.

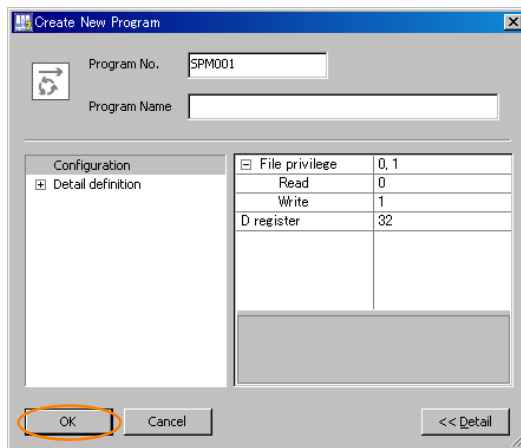

4. Enter the motion program.

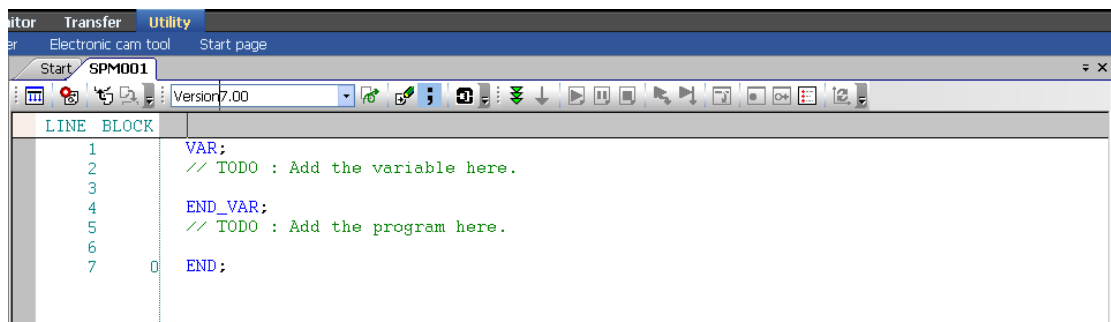

- 5. Select **Compile - Compile** from the menu bar to compile the program. When the compilation is finished, the motion program will be saved automatically.

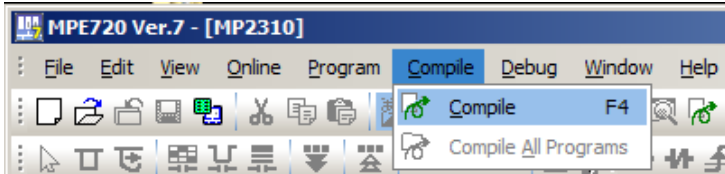

 Important

If an error occurs during compilation, the motion program will not be saved.

4.4.2 Creating a Sequence Subprogram

Use the following procedure to create a sequence subprogram.

- 1. Start the Motion Editor.
- 2. Expand the tree structure in the Motion Pane. Right-click **Sub program**, and select **New**.

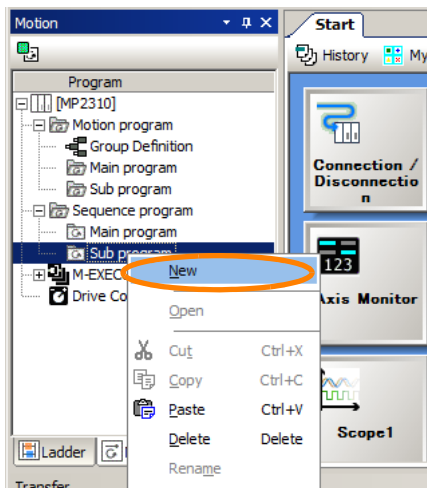

- 3. Click the **OK** Button.

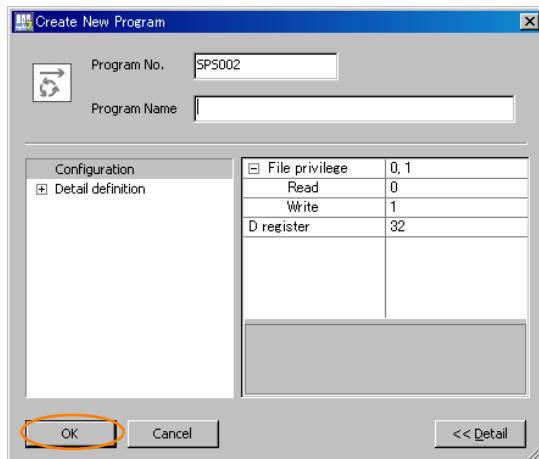

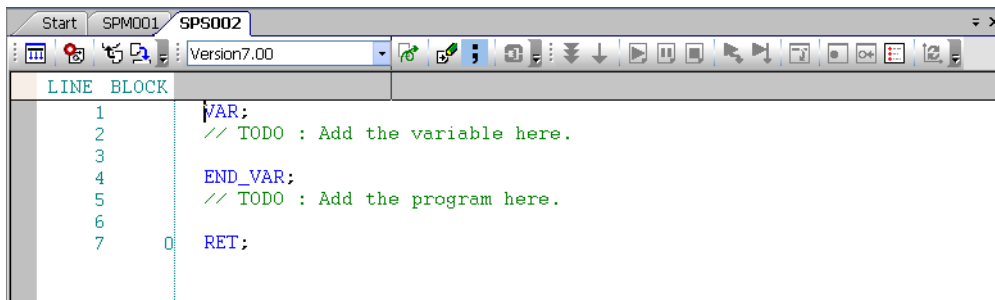

4. Enter the sequence program.



The screenshot shows the Motion Editor interface with a window titled 'SP5002'. The interface includes a toolbar at the top and a main editing area. The editing area has two columns: 'LINE' and 'BLOCK'. The content is as follows:

LINE	BLOCK
1	VAR;
2	// TODO : Add the variable here.
3	
4	END_VAR;
5	// TODO : Add the program here.
6	
7	RET;

5. Click the **Save** Icon () in the Motion Editor to compile the program. When the compilation is finished, the sequence program will be saved automatically.



Important If an error was displayed in the Error List Dialog Box during compilation, the sequence program will not be saved.

4.5 Transferring Data with the MPE720

You can transfer data to read, write, and compare data between the external memory (MPE720 or CF card) and the Machine Controller, and save the RAM data in the Machine Controller to flash memory.

You can transfer the following data.

- System Configuration
 - System definitions
 - Scan time definitions
 - Module configuration definitions
 - Trace data
- Programs
 - Ladder programs (high-speed, low-speed, startup, and interrupt programs, and functions)
 - Motion programs (main program, subprograms, and group definitions)
 - Table data
 - Variables (axis, I/O, global, constant, and user-defined structure variables)
 - Comments (I/O, global, and constant comments)
- Registers
 - M (data), D (internal), C (constant), S* (system), I* (input), O* (output), and G (G) registers

* The contents of these registers cannot be changed.

The type of data transfer is selected in the Transfer Dialog Box. Display this dialog box by selecting **Online - Transfer** from the menu bar.

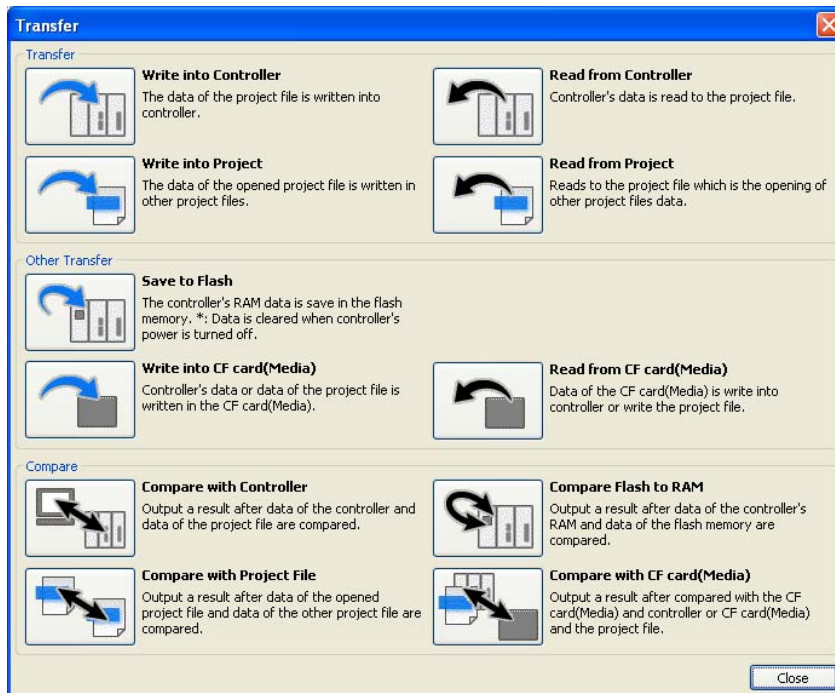

- Note: 1. In the above dialog box, all icons are shown as enabled for the purpose of this description.
 2. To transfer data from the main menu, select *Online - Write into Controller*, *Read from Controller* or *Save to Flash*.
 3. You can also transfer data by selecting the Transfer Icon in the Launcher, then select *Write into Controller*, *Read from Controller*, or *Save to Flash*.

The following figure illustrates data transfers for MPE720 version 7.

<Data Transfer Conceptual Diagram>

Writing into the Machine Controller and Saving to Flash

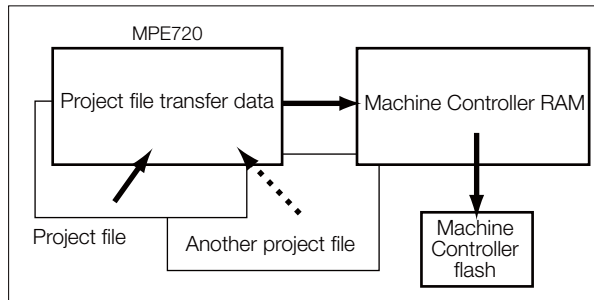

When you perform a Write into Controller operation from the Transfer Dialog Box, the data of the open project file (or of another project file that you specified) will be written to the RAM of the Machine Controller. If you perform a Save to Flash operation, the data that is stored in the RAM of the Machine Controller will be written to the flash memory of the Machine Controller.

Reading from the Machine Controller

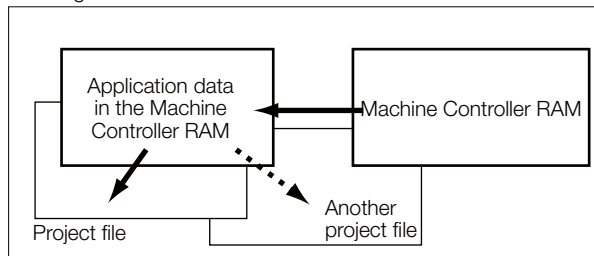

When you perform a Read from Controller operation from the Transfer Dialog Box, the data in the RAM of the Machine Controller will be loaded into the MPE720 and written to the open project file (or to another project file that you specified).

The following sections provide the data transfer procedures.

4.5.1 Writing Parameters to the Machine Controller

The operation depends on whether a project file is currently open.

- When a project file is open (i.e., when you are online), the current project file data will be transferred to the Machine Controller.
Go online with the Machine Controller before performing the transfer.
- When a project file is opened and a connection is established (i.e., when a project link connection is made), the Transfer Program Dialog Box is displayed when you select the operation from the Transfer Dialog Box.
- When a connection is established without opening a project file (i.e., when a direct connection is made), you select the transfer source project file and then transfer the data to the Machine Controller.

4.5.2 Writing into a Project File

You can write the data from the currently open project to another project file.



Important You can write to a project file only when the Machine Controller is not connected (i.e., when offline).

Use the following procedure to write the data.

1. Select **Online - Transfer** from the menu bar, and then click the **Write into Project** Button in the Transfer Dialog Box.
The Open Project Dialog Box will be displayed.
2. Select the project file to which to write the data, and then click the **Save** Button.

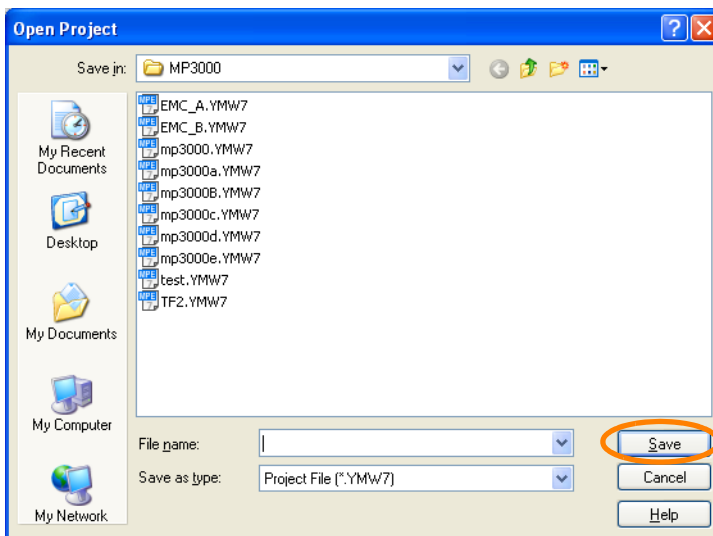

The *Transfer Program - Write into Project* Dialog Box will be displayed.

3. Click the **Batch** Button or the **Individual** Button.
If you click the Batch Button, use the check boxes to indicate the data to transfer: System Configuration, Program, Register, and/or Global register comment.
If you click the Individual Button, use the check boxes to indicate the data to transfer: System Configuration, Program, Register, and/or Global register comment. You can then specify the individual data to transfer.

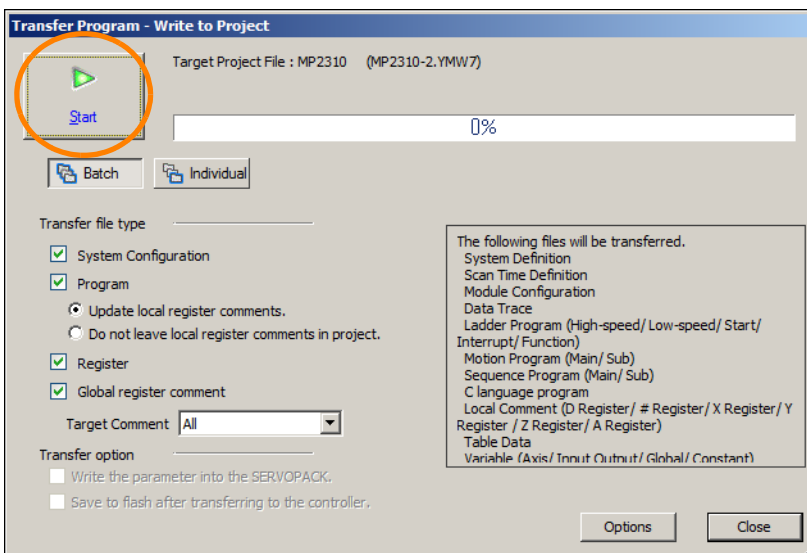

4. Click the **Start** Button to start writing to the project file.

When the Project File Is Open and the Machine Controller Is Online

Select *Online - Write into Controller* from the menu bar.

Alternatively, you can select *Transfer - Write into Controller* from the Launcher.

The *Transfer Program - Write into Controller* Dialog Box will be displayed.

4.5.3 Reading from the Machine Controller

The operation depends on whether a project file is currently open.

- When a Project File Is Open:
The RAM data of the Machine Controller will be transferred to the current project file. If the Machine Controller is offline, a connection to the Machine Controller is established before performing the transfer.
- When a Connection Is Established without Opening a Project File:
The data in the Machine Controller will be transferred to the target project file after the file is selected.

When the Project File Is Open and the Machine Controller Is Online

Select *Online - Read from Controller* from the menu bar.

Alternatively, you can select *Transfer - Read from Controller* from the Launcher.

The *Transfer Program - Read from Controller* Dialog Box will be displayed.

4.5.4 Reading from a Project File

You can read data from another project file into the currently open project. You can write to a project file only when the Machine Controller is not connected (i.e., when offline).

Use the following procedure to read the data.

1. Select **Online - Transfer** from the menu bar, and then click the **Read from Project Button** in the Transfer Dialog Box.
The Open Project Dialog Box will be displayed.
2. Select the project file from which to read the data, and click the **Open Button**.

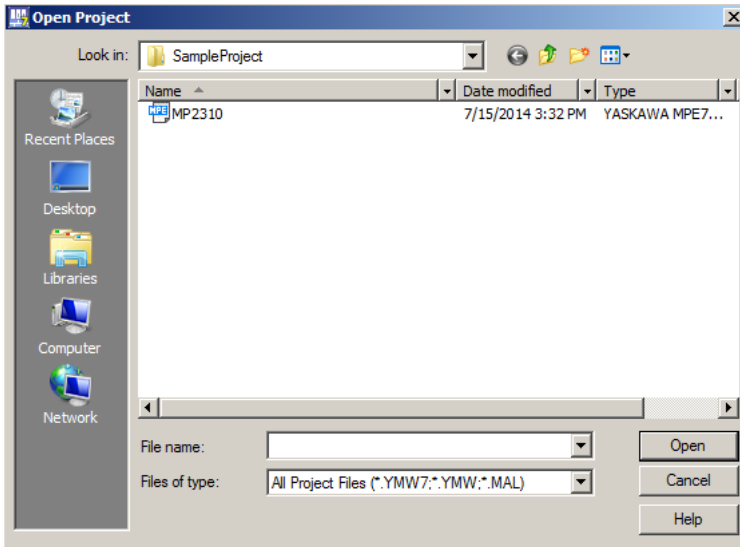

The *Transfer Program - Read from Project* Dialog Box will be displayed.

3. Click the **Batch Button** or the **Individual Button**, and then the **Start Button**.
If you click the Batch Button, use the check boxes to indicate the data to transfer: System Configuration, Program, Register, and/or Global register comment.
If you click the Individual Button, use the check boxes to indicate the data to transfer: System Configuration, Program, Register, and/or Global register comment. You can then specify the individual data to transfer.

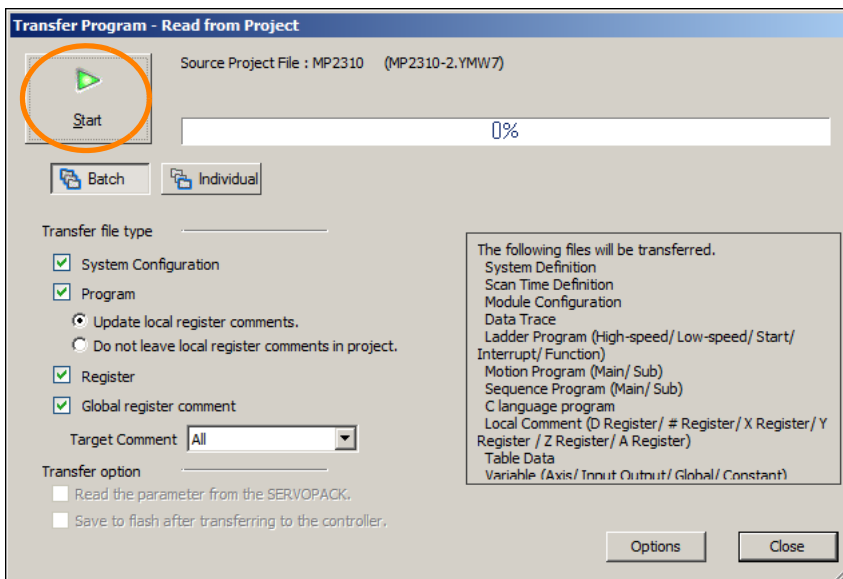

4.5.5 Saving to Flash Memory

You can save the Machine Controller RAM data to the flash memory of the Machine Controller.



You can save the data to flash memory only when the Machine Controller is connected (online).

Use the following procedure to save the data.

1. Select **Online - Save to Flash** from the menu bar.
The *Transfer Program - Save to Flash* Dialog Box will be displayed.
2. Click the **Start** Button.

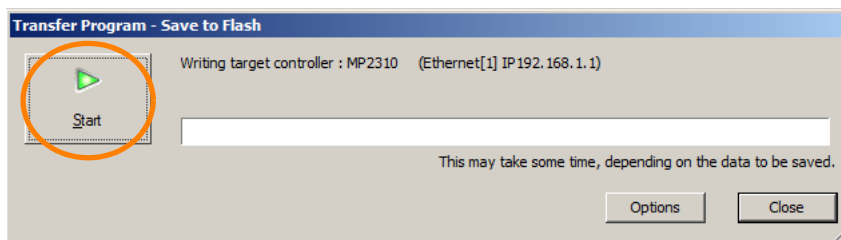

If the CPU Module is running, the following message will be displayed. Click either the **Yes** or the **No** Button to save the data to the flash memory.

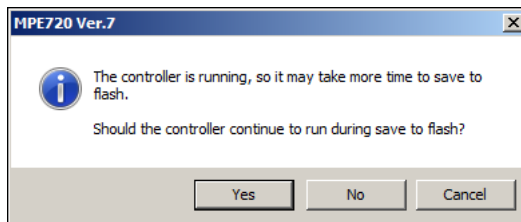

4.5.6 Using a CF Card (MP2200 Only)

You can use a CF card to write or read data only with the MP2200 (CPU-02 or CPU-03). This section provides the procedures.

Writing to a CF Card

You can write data to a CF card. The operation depends on whether the project file is currently open.

- When a Project File Is Open:
The data in the current project file will be transferred to the CF card.
- When a Connection Is Established without Opening a Project File:
The Machine Controller (MP2200 CPU-02) RAM data will be transferred to the CF card installed in the PC.

Use the following procedure.

1. Select **Online - Transfer** from the menu bar, then click the **Write into CF Card (Media)** Button in the Transfer Dialog Box.
The Select Drive Dialog Box will be displayed.
2. Select the drive to use and click the **OK** Button.

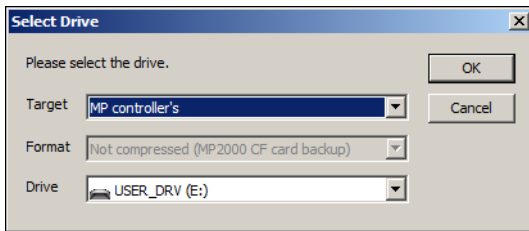

The Transfer Program – Write to CF Card (Media) Dialog Box will be displayed.

3. Use the check boxes to indicate the data to transfer: System Configuration, Program, Register, and/or Global register comment, and click the **Start** Button.

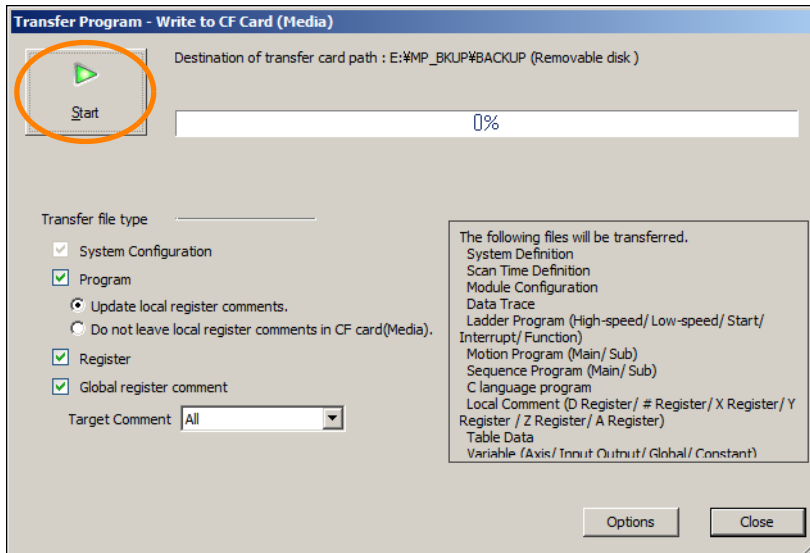

Writing to the CF card will start.

Reading from a CF Card

You can read data from a CF card.

The operation depends on whether the project file is currently open.

- When a Project File Is Open:
The data on the CF card will be transferred to the current project file. If the Machine Controller is offline, a connection to the Machine Controller (MP2200 CPU-02 or CPU-03) is established before performing the transfer.
- When a Connection Is Established without Opening a Project File:
The data on the CF card will be transferred to the Machine Controller (MP2200 CPU-02 or CPU-03).

Use the following procedure.

1. Select **Online - Transfer** from the menu bar, then click the **Read from CF Card (Media)** Button in the Transfer Dialog Box.
The Select Drive Dialog Box will be displayed.

2. Select the drive to use and click the **OK** Button.

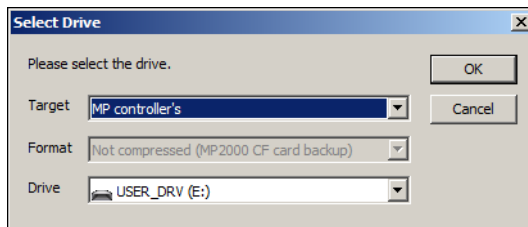

The Transfer Program – Read from CF Card (Media) Dialog Box will be displayed.

3. Click the **Options** Button.

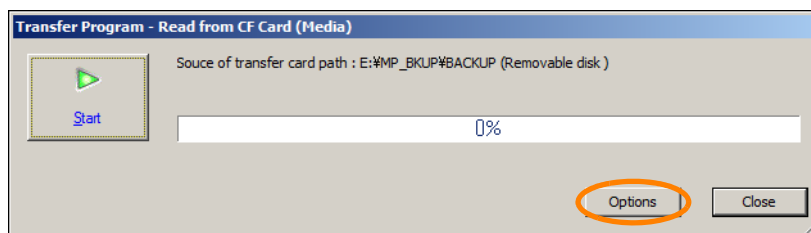

4. Change transfer-related settings, if necessary, and click the **OK** Button.

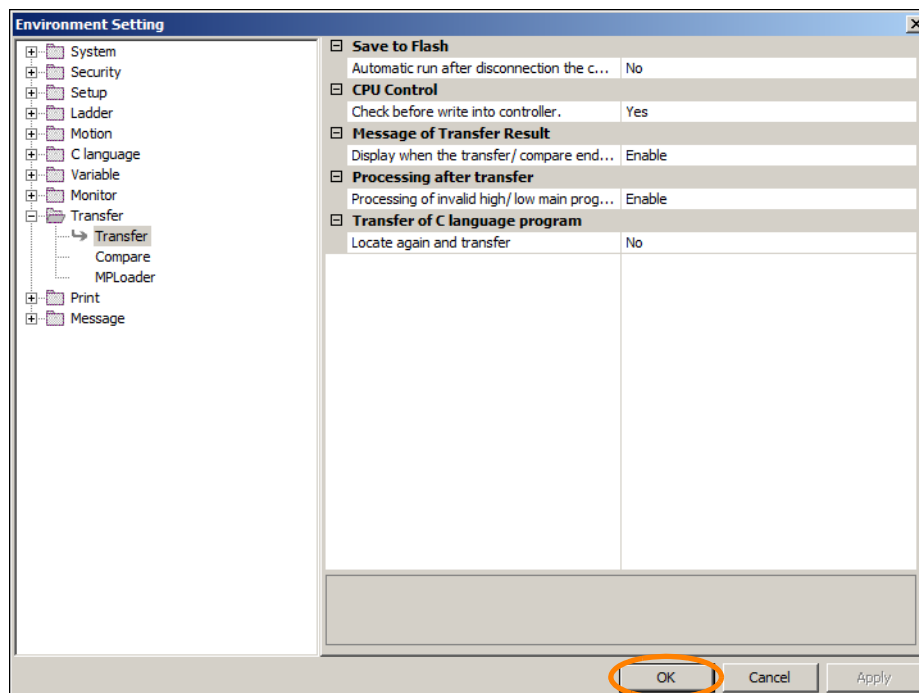

5. Click the **Start** Button.

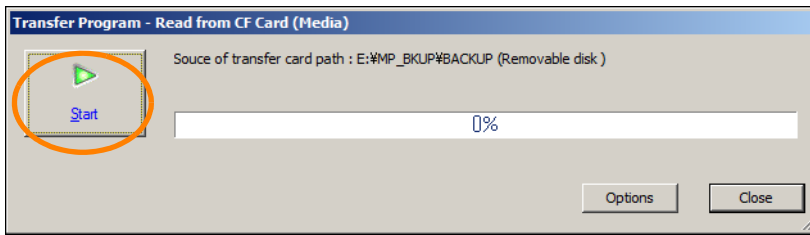

Reading from the CF card will start.

4.5.7 Comparing to the Machine Controller

The operation depends on whether a project file on the PC is currently open (offline) or whether the Machine Controller is online.

- Offline
After a connection to the Machine Controller is established, the currently open project file data and the Machine Controller RAM data will be compared, and the results will be displayed in the Transfer Pane.
- Online
When you specify (or create) a project file to compare, the project file data and the Machine Controller RAM data will be compared, and the results will be displayed in the Transfer Pane.

4.5.8 Comparing Flash Memory and RAM Data

The Machine Controller RAM data and the flash memory data will be compared, and the results will be displayed in the Transfer Pane. You can save the data to flash memory only when the Machine Controller is connected (online).

4.5.9 Comparing to a Project File

The currently open project file data and the data in another project file will be compared, and the results will be displayed in the Transfer Pane. This comparison can be executed only when the Machine Controller is offline.

4.5.10 Comparing to a CF Card

You can compare the data on the CF card to the data in the Machine Controller or in a project file.



The operation depends on whether a project file on the PC is currently open (offline) or whether the Machine Controller is online.

- When a Project File Is Open:
The current project file data and the data on the CF card will be compared, and the results will be displayed in the Transfer Pane.
- When Connected to the Machine Controller (MP2200 CPU-02 or CPU-03)
The Machine Controller (MP2200 CPU-02 or CPU-03) RAM data and the CF card data will be compared, and the results will be displayed in the Transfer Pane.

4.6

Data Transfer without Using the MPE720

This section describes how to transfer project file data without using the MPE720.

Method	Reference
Using a CF Card (MP2200 only)	 <i>Using a CF Card (MP2200 Only) (page 4-69)</i>
Using the MPLoader	 <i>Using the MPLoader (page 4-72)</i>
Using the MPLoad Maker	 <i>Using the MPLoad Maker (page 4-74)</i>

4.6.1 Using a CF Card (MP2200 Only)

You can use a CF card to write or read data only with the MP2200 (CPU-02 or CPU-03). This section provides the procedures.

Specifications

The following table gives the Compact Flash interface specifications.

Item	Specifications	Description
Slot standard	Compact Flash Type I	50 pins
Number of slots	1	–
Interface	PC Card ATA	True IDE is not supported.
Supported media	Compact Flash Type I	–
Media memory capacity	32 MB, 64 MB, 128 MB, 256 MB, 512 MB	–
Partitioning	Not supported.	–
Applicable FAT	FAT12, FAT16, FAT32, or VFAT (long names)	When using VFAT, the maximum file name length is 256 characters. However, in practice it is only 246 characters max., due to full path designation.
Maximum number of nested directories	10	–
File information	Last update timestamp supported.	Uses the calendar in the Controller.
Maximum length for file name and directory names	256 characters	Total characters in the file name and directory names
Current directory function	Not supported.	–
Maximum number of simultaneously opened files	16	–

Function Specifications

The following table gives the functional specifications of the Compact Flash interface.

Item	Specification	Description
Operation switches	Uses 3 pins on SW2.	CARD: Enables/disables the use of the media. LOAD: Performs batch loading when the power is turned ON. SAVE: Performs batch saving when switched from OFF to ON.
Batch load	CF card to CPU Module (flash memory)	<ul style="list-style-type: none"> Controls the operation based on the settings of the above operation switches. User applications and registers are transferred.
Batch save	CPU Module (SDRAM) to CF card	

Writing to a CF Card

You can use a DIP switch to write the user application data that is stored in the RAM to the CF card without using the MPE720.

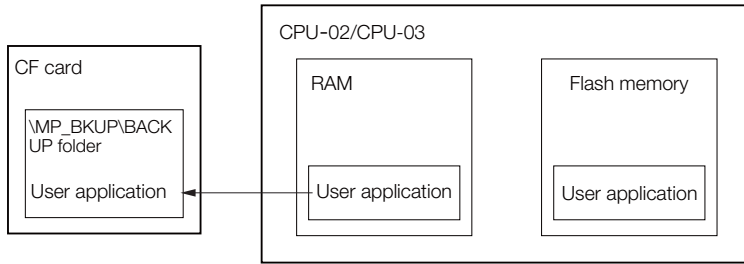

- Note:
1. If there is already data on the CF card, it will be overwritten.
 2. If motion registers are used in the trace definitions and the appropriate Motion Module is not defined or not mounted, the data will not be written.
 3. CPU versions 2.41 or lower do not have a security function for the CF program transfer.

Use the following procedure to write the data to the CF card when using the CPU-02.

1. Confirm that the **CARD**, **LOAD**, and **SAVE** pins on the SW2 switch of the CPU-02 Module are **OFF**.

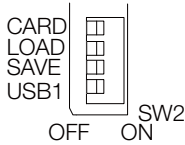

2. While the power supply is **ON**, insert a formatted CF card into the CF slot of the CPU-02 Module.
3. Turn **ON** the **CARD** pin.
The PWON indicator will light.
4. Turn **ON** the **SAVE** pin.

Writing will start, and the **CARD** indicator will light. When saving is completed, the **CARD** indicator will go out.

Note: If saving fails, the **ALM** indicator will light, and error information will be reported in the SW00658 system register.
The **ALM** indicator will go out if you redo the batch saving operation or if you restart the MP2200.

- Information**
- You can read the application data that you wrote to the CF card from the MPE720.
 - It is possible to write application data from the MPE720 to the CF card, but the data is limited to a batch dump of the application data from the Controller. A writing error may occur if the application data that you try to write into the CF card was created or edited offline. Refer to the following section for information on writing application data to the CF card from the MPE720.

[4.5 Transferring Data with the MPE720 – Using a CF Card \(MP2200 Only\) – Writing to a CF Card \(page 4-66\)](#)

Reading from a CF Card

You can use a DIP switch to read the user application data that is stored in the CF card into the RAM, and then save it to the flash memory.

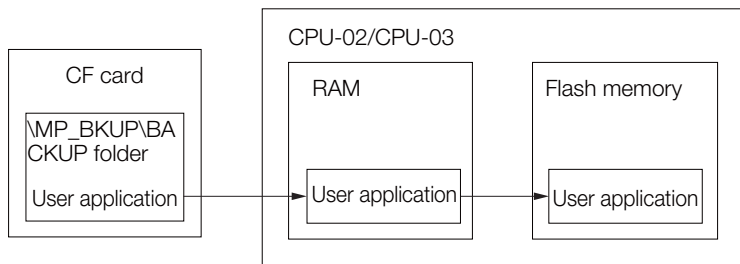

Use the following procedure to read data from the CF card when using a CPU-02.

1. While the power supply is OFF, insert the CF card that contains the application data backup into the CF slot of the CPU-02 Module.
2. Turn ON the CARD and LOAD pins of the SW2 switch on the CPU-02 Module.

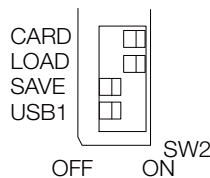

3. Turn ON the power supply to the MP2200-series Machine Controller.
The PWON indicator will light and reading will start. The CARD indicator will light, and the RUN indicator will flash.
When reading from the CF card is completed, the CARD indicator will go out.
When saving is completed, the RUN and the PWON indicators will go out.
Note: If loading fails, the ALM indicator will light, and error information will be reported in the SW00658 system register.
The ALM indicator will go out when the MP2200 is restarted.
4. Turn OFF the power supply to the MP2200-series Machine Controller.
5. Turn OFF the CARD, LOAD and INIT pins, and then turn ON the power and restart the MP2200 (a flash startup).

Refer to the following manual for details.

📖 MP2200 User's Manual (Manual No.: SIEP C880700 14)

4.6.2 Using the MPLoader

The MPLoader software was developed to provide an easy way for users to modify the internal definition files, application programs, and register data in a Machine Controller without using the MPE720. The following table lists the various models of this product.

The model depends on the number of PCs that the software can be installed on.

Name	Model	Description
MPL700 Client	CPMC-MPL700C	Single license
	CPMC-MPL700C-10	10 licenses
	CPMC-MPL700C-20	20 licenses

Function

◆ Loading Application Data

- MPLoader version 3.00 and higher can load MPE720 version 7 project files (YMW files) into the Machine Controller.
- The folder containing all of the data for one Machine Controller in the MPE720 can be loaded into the Machine Controller in a batch operation.
- You can make setting when creating the data that is loaded into the Machine Controller to also back up the application that is already loaded into the Machine Controller.

◆ Saving to Flash Memory

The MPL700 Client can save data to flash memory.

System Requirements

The following table gives the system requirements.

Item	Specification
CPU	Pentium II, 400 MHz min.
RAM	128 MB min.
HD	Space is required for software installation. MPL700C software installation: 30 MB
Display resolution	800 × 600 min.
OS	MPLoader Ver.3: Windows 2000, Windows XP, Windows Vista, Windows 7 MPLoader Ver.4: Windows 7 (32-bit or 64-bit edition), Windows 8, Windows 8.1 or Windows 10 (32-bit or 64-bit edition)
Software environment	.NET Framework 4.6.2

Applicable Models and Communications Interfaces

The following models and communications interfaces can be used with the MPL700 Client:

- Model: MP2000-series Machine Controller
- Communications: Serial (RS-232C), Ethernet (except relay and duplex), PCI bus (for MP2100, MP2100M, MP2101, MP2101M, MP2101T, or MP2101TM), or USB (for MP2200-02)

MPL700 Features

The MPL700 provides an easy way to load updated applications to the end-user systems without using the MPE720. Therefore, unlike the MPE720, it does not have functions for system configuration definitions, programming, monitoring, and other operations.

The application provider sends the compressed application file to the user. The end user can specify the received compressed file in the MPL700 to load the application into the Machine Controller.

◆ Overall Workflow

The following figure shows the dataflow until the updated application is loaded into the end-user system (CPU Module) using the MPL700 Client.

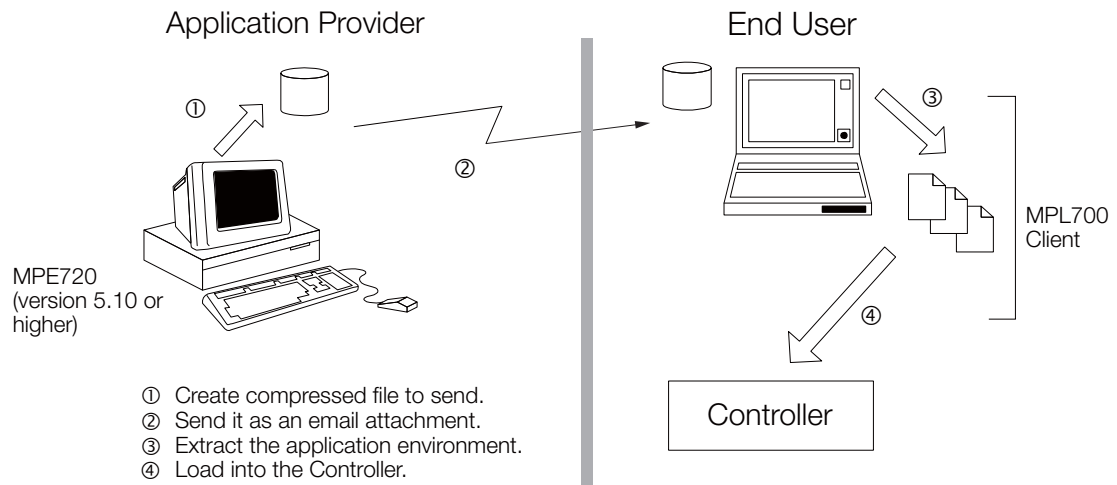

① : Create the compressed file for sending with the compressed sending function of the MPE720 (version 5.10 or higher).

This is the same function as the one supported by the MPL700 Server.

MPLoader version 3.00 or higher can also be used to send MPE720 version 7 project files (YMW files).

③④ : Load the compressed file that was provided into the Machine Controller with the MPL700 Client.

② indicates transfer via a network, removable disk, or other methods that are not automatically supported by this software.

Refer to the following manual for details on the features and operation of the MPLoader.

📖 MP2000/MP3000 Series MPLoader Ver. 4 User's Manual (Manual No.: SIEP C880761 01)

📖 MP900/MP2000-series MPLoader Client User's Manual (Manual No.: SIEZ-C887-12.2)

4.6.3 Using the MPLoad Maker

The MPLoad Maker is used to create automatically startup files (Auto_MPL) from a Machine Controller applications that were created on a development PC. The Auto_MPL file that is created with the MPLoader Maker is written onto a CD-ROM. The CD-ROM (hereafter Auto_MPLCD) is inserted into the target PC that is located in the system of the Machine Controller, and serves the purpose of transferring applications. The Auto_MPL automatically extracts the application and transfers it into the target Machine Controller.

Instead of using a CD-ROM, a .BAT file, that can start up from the HDD can also be created. The following figure outlines the transfer process.

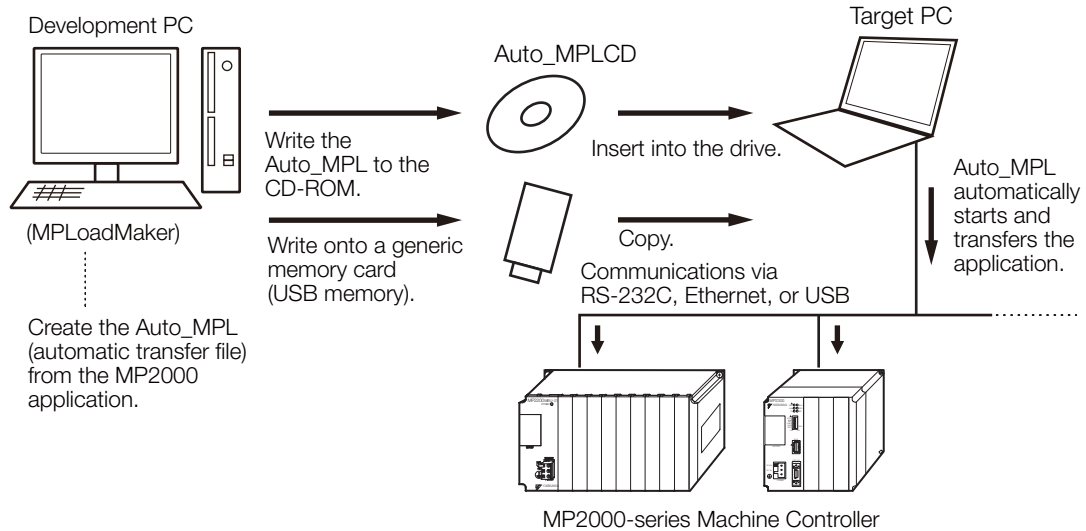

Note: The MPLoad Maker does not have the functionality to write a CD-ROM. Use a specific device and driver to write the CD-ROM.

MPLoad Maker Features

- Applications can be transferred even if there is no application transfer software (MPE720 or MPLoader) installed on the target PC.
- One Auto_MPLCD can be used to transfer the application into more than one Machine Controller.

The functionality of the Auto_MPL is limited to extracting and transferring applications. This eliminates the risk of the application being accidentally edited on the target PC.

MPLoad Maker Product Specifications

The following table lists the product specifications of the MPLoad Maker.

Item	Development PC (MPLoad Maker)	Target PC
Applicable Machine Controllers	MP2100, MP2100M, MP2101, MP2101M, MP2101T, MP2101TM, MP2200 (CPU-01/02/03/04), MP2300, MP2310, MP2300S, MP2400, MPU-01	
CPU	Pentium II, 400 MHz min.	
RAM	128 MB min.	–
Display resolution	800 × 600 min.	–
Applicable OS	Windows 7, 8, 8.1 and 10 (32-bit or 64-bit edition, English or Japanese)	
Applicable communication interfaces and corresponding Communications Modules	–	Ethernet 218IF-01* ¹ 218IFA* ¹ 218IFB* ¹ 218IFC* ¹ 218IFD* ¹ Serial (RS-232C) 217IF-01* ¹ 218IF-01* ¹ 260IF-01 261IF-01 215AIF-01 USB MP2200 (CPU-02) PCI Bus MP2100 MP2100M MP2101 MP2101M MP2101T MP2101TM
Transferable files	YMW/YMW7 file (project file that was created with MPE720 Version 6 or Version 7)	
Consecutive application transfers	–	Supported.
Installation size	30 MB	Installation is not required.
Available HDD space for execution	25 MB* ² (for one Auto_MPL)	1 MB* ² (released when the transfer is completed)

*1. Relay settings are not supported.

*2. More space may be required depending on the size of the transferred application.

Refer to the following manual for details on the features and operation of the MPLoad Maker.

 MP2000/MP3000 Series MPLoad Maker Version 4 User's Manual Auto Transfer File Creation Tool
(Manual No.: SIEP C880761 02)

Debugging Programs

5

This chapter describes how to debug programs and how to adjust the operation of the machine.

5.1 Debugging Ladder Programs 5-3

- 5.1.1 Ladder Program Runtime Monitoring 5-3
- 5.1.2 Register List Panes 5-4
- 5.1.3 Watch Panes 5-7
- 5.1.4 Searching and Replacing in Programs 5-8
- 5.1.5 Searching and Replacing in Project Files 5-10
- 5.1.6 Cross Reference Panes 5-14
- 5.1.7 Checking for Multiple Coils 5-17
- 5.1.8 Forcing Coils ON and OFF 5-17
- 5.1.9 Viewing a Called Program 5-20
- 5.1.10 Enabling and Disabling a Program 5-20

5.2 Debugging a Motion or a Sequence Program .. 5-21

- 5.2.1 Tab Page Items 5-22
- 5.2.2 Monitoring Program Execution 5-23
- 5.2.3 Register List Panes 5-24
- 5.2.4 Watch Panes 5-24
- 5.2.5 Searching and Replacing in Programs 5-24
- 5.2.6 Searching and Replacing in Project Files 5-24
- 5.2.7 Viewing a Motion Subprogram 5-25
- 5.2.8 Cross Reference Searches 5-25
- 5.2.9 Alarm Monitor 5-25
- 5.2.10 Alarm Code Details 5-27

5.3 Monitoring Machine Operation 5-30

- 5.3.1 Axis Monitor 5-30
- 5.3.2 Alarm Monitor 5-34
- 5.3.3 Introduction to Tracing 5-38

5.4	Tuning	5-63
5.4.1	Using SigmaWin+ (When Using a Servo)	5-63
5.4.2	Using DriveWizard Plus (When Using an Inverter)	5-63

5.1 Debugging Ladder Programs

This section describes debugging with MPE 720 version 7.

5.1.1 Ladder Program Runtime Monitoring

You can monitor the execution status of each instruction. Using runtime monitoring requires a connection to the Machine Controller.

Instructions where the relay output is ON are displayed in blue.

The current values of the parameter registers of the instructions that are being executed are also displayed.

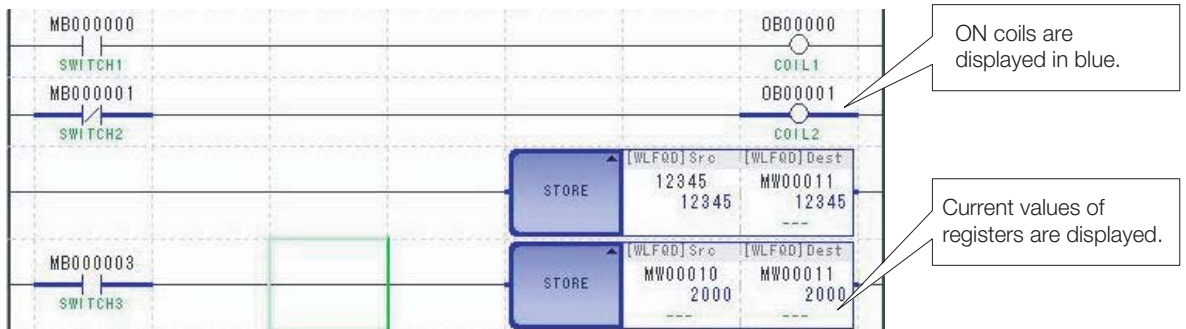

5.1.2 Register List Panes

You can monitor the current values of the registers in a continuous area (register map) on any of the Register List 1, 2, and 3 Panes. Realtime monitoring is possible if the Machine Controller is connected. You can edit the values.

- Information**
 - If you use a project link connection, the data in the Machine Controller is accessed. When the register map is displayed, the displayed results do not always match the project file of the linked project. If you display the register map when using a project link connection, first always transfer the data to the project file by reading the data from the Machine Controller.
 - The register list can display S, I, O, M, C, D, and G registers. However, C registers are read-only. They can be read but not written.

Displaying the Register Map

The following table gives the meaning of the background colors in the register map.

Green	Indicates a register that is used in a ladder program.
Red	Indicates a redundant register (i.e., a register that is used for more than one data type).

Use the following procedure to display the register map.

- Click one of the tabs for the Register List 1, 2 or 3 Panes. Select **Monitor – Register List** from the Launcher. The Register List 1 Pane will be displayed. Note: You can show or hide the Register List 1, 2, and 3 Panes by selecting **View – Register List – Register List 1**, **View – Register List 2**, or **View – Register List 3** from the menu bar.
- Enter the address of the register to display in the Register Box. When displaying a list of D registers, enter the program number as shown below.

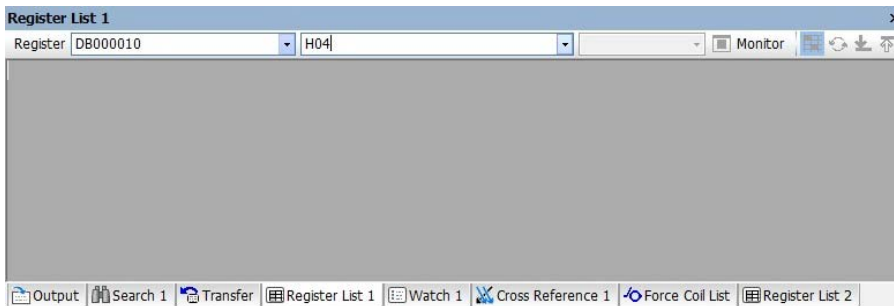

- When you press the **Enter** Key, the register map will be displayed. The specified register will be displayed in the top row.

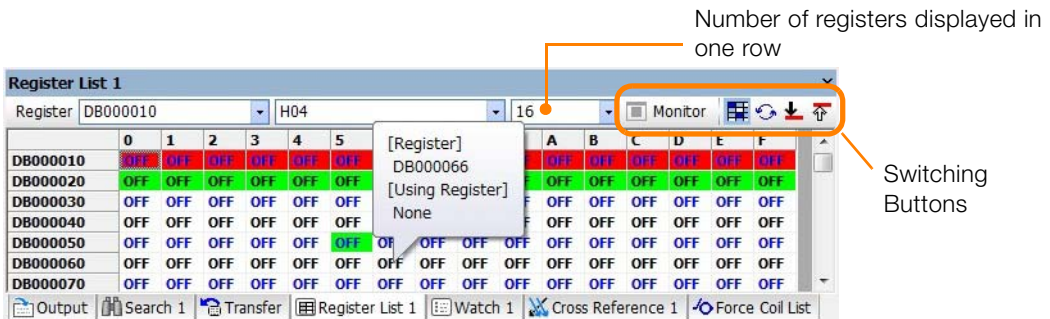

Example of Displaying the D Register Map and Balloon

Register	0	1	2	3	4	5	6	7
MW00014	0	0	0	0	0	0	0	0
MW00022	0	0	0	0	0	0	0	0
MW00030	0	0	0	0	0	0	0	0
MW00038	0	0	0	0	0	0	0	0
MW00046	0	0	0	0	0	0	0	0
MW00054	0	0	0	0	0	0	0	0
MW00062	0	0	0	0	0	0	0	0

Example of an M Register Map

- Information**
- If you move the cursor over the register map, a balloon will show the register and the status of the register at the cursor position.
 - You can change the number of registers displayed in one row. The five buttons on the top right of the pane are used to switch the displayed contents.
 - If you right-click the register list, you can select **Decimal**, **Hex**, **Binary**, or **ASCII** from the pop-up menu to change the data type of the values. However, the B and F data types cannot be changed.
 - The display color alternate between blue and black for every other row.
 - The **Monitor** icon is enabled only when the Machine Controller is online.

Switching the Register Map Display

You can change the number of registers that is displayed in one row. You can use the five buttons on the top right to switch the displayed contents of the register map.

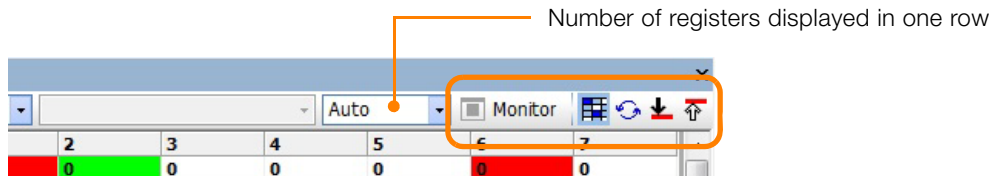

◆ Number of Registers Displayed in One Row

You can set the number of registers displayed in a row to between 1 and 16 either by direct numeric input or by selection from a list. For bit registers, the number is always 16 and cannot be changed. If you select **Automatic**, the number of displayed registers will be set automatically based on the size of the Register List Pane.

◆ Monitor ON ()/OFF () Button

This button is enabled only in Online Mode. Click this button to turn monitoring ON and OFF. When monitoring is ON, the register data will be updated and displayed continuously. When monitoring is OFF, the data will not be updated.

◆ Register Map Show ()/Hide () Button

Click this button show and hide the register map.

Show mode: Registers that are used in the ladder program are displayed with a green background, and registers that are used for more than one data type are displayed with a red background.

Hide mode: All registers are displayed with a white background.

◆ Register Map Refresh Button (↻)

Click this button to refresh the values in the register map.

Information This button is disabled when the Register Map Show/Hide Button is in Hide (☒) status.

◆ Redundant Register Search Button (↑/↓)

This button searches for and displays redundant registers. The [↑] Button searches for redundant registers upward, and the [↓] Button searches downward.

The results will be displayed on the register map. If a redundant register was found, it will be displayed with a blue background.

Information This button is disabled when the Register Map Show/Hide Button is in Hide (☒) status.

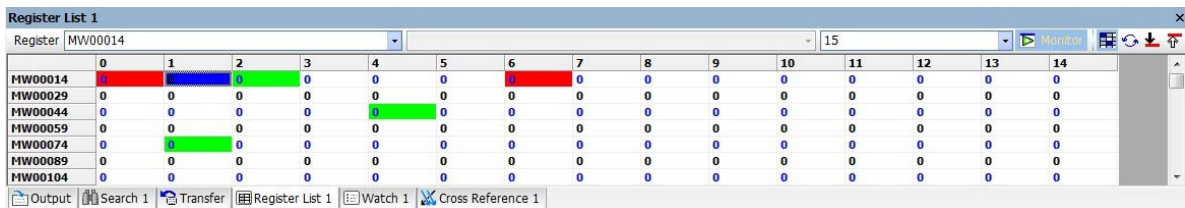

Editing Data

You can perform the following editing operations by selecting cells on the register map.

- Directly entering data
- Deleting data (setting the data to 0)
- Copying and pasting data

If the Machine Controller is online, any changes in the data immediately affect the operation of the Machine Controller.

5.1.3 Watch Panes

You can monitor the values and comments of the specified S, I, O, M, C, D, and G registers on the Watch 1, 2, and 3 Panes. Realtime monitoring is possible if the Machine Controller is connected. You can edit the values.

Information When a project link is used, the data registered in the Watch Pane is saved only to the Machine Controller. To apply the watch data to the project file, transfer all of the data from the Machine Controller.

Displaying Watch Data

1. Click one of the tabs for the Watch 1, 2 or 3 Panes.

Select **Monitor – Watch** from the Launcher. The Watch 1 Pane will be displayed.

Note: You can show or hide the Watch 1, 2, and 3 Panes by selecting **View – Watch – Watch 1**, **View – Watch – Watch 2**, or **View – Watch – Watch 3** from the menu bar.

2. Double-click the **Variable** Column or press F2 to show the text cursor, and then enter the register or variable register to monitor.

Note: 1. You can also drag or copy registers from the ladder program or from the Variables Pane.

2. When monitoring D registers, enter the program number as shown below.

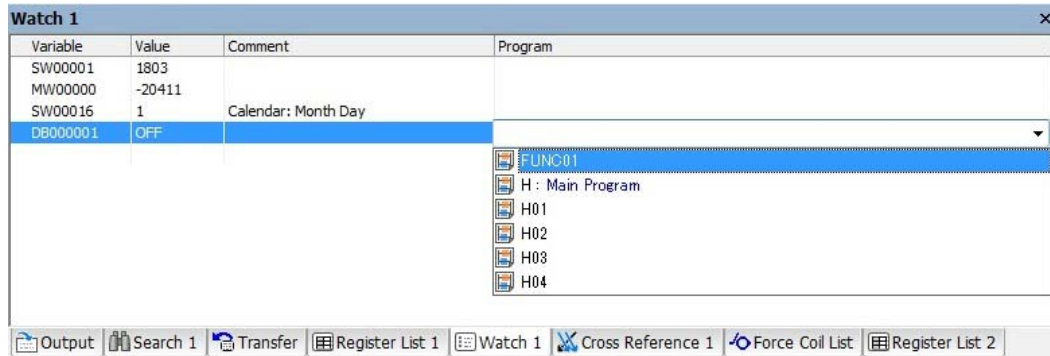

3. Press the **Enter** Key.

The contents of the specified register will be displayed.

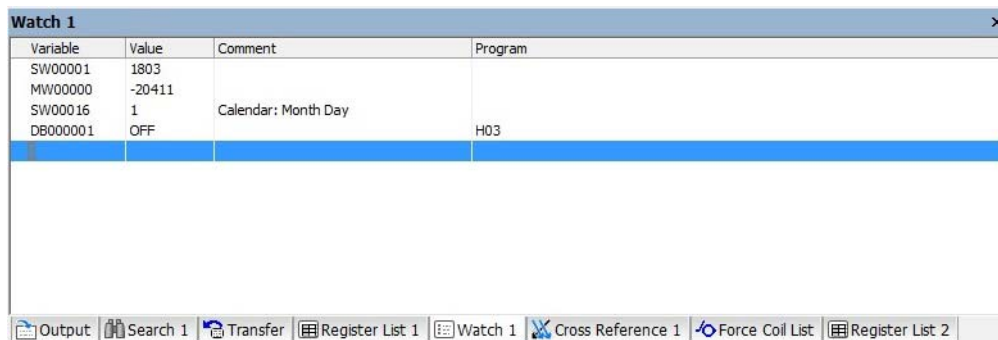

If you right-click a row, you can select **Decimal**, **Hex**, **Binary**, or **ASCII** from the pop-up menu to change the data type of the **Value** Column.

Editing the Value Column

Double-click the **Value** Column or press F2 to show the text cursor. You can enter the value directly or paste a value.

Information You cannot edit the comments of the system registers.

After entering the data, press the **Enter** Key to confirm the change.

If the Machine Controller is online, any changes in the data immediately affect the operation of the Machine Controller.

5.1.4 Searching and Replacing in Programs

You can search for variables, instructions, and comments in a specified program. You can also search for and replace registers and register comments.

The following section describes how to search for and replace text in programs.

Searching in Programs

1. Bring the program to search to the front in the Ladder Editor, and then select **Edit – Find** from the menu bar.
The Search Dialog Box will be displayed.
2. Click the Variable, Instruction or Comment/Bookmark Tab to set the search criteria.

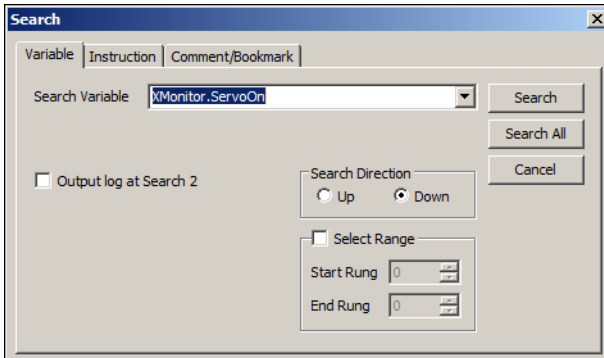

Variable Tab Page: Allows you to search for variables and registers. You can also enter the variable by copying it from the Variables Pane.

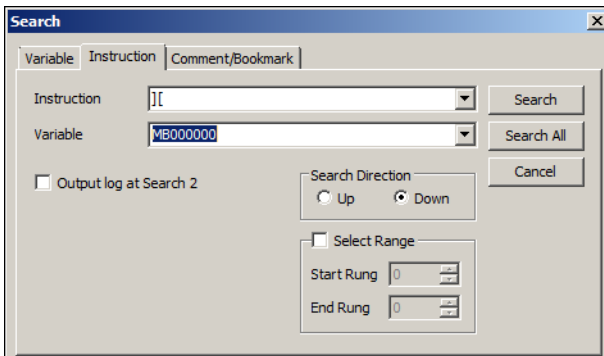

Instruction Tab Page: Enter the name of the instruction or the assigned instruction key in the **Instruction** Box.

The **Variable** Box is displayed when an instruction is entered in the **Instruction** Box. If the SEE instruction is entered in the **Instruction** Box, **Variable** changes to **Program Name**. You can also enter the variable by copying it from the Variables Pane.

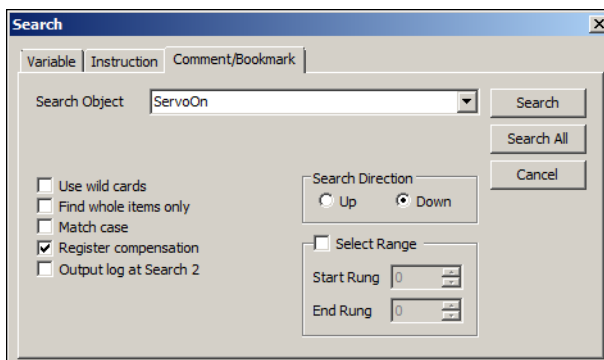

Comment/Bookmark Tab Page: Allows you to search for object comments, rung comments, program comments, expression comments, and bookmark.

- **Use wild cards** Check Box: Select this check box to use wildcard characters (* and ?) in the search string.
 - **Find whole items only** Check Box: Select this check box to search for comments where the string in the **Search Object** Box is exactly the same as the search string. However, case matching is controlled by the **Match case** Check Box.
 - **Match case** Check Box: Select this check box to differentiate between uppercase and lowercase characters.
 - **Register compensation** Check Box: Select this check box to convert search strings that are recognized as registers into register notation.
 - **Output log at Search 2** Check Box: Select this check box to display the search results in the Search 2 Pane without changing the contents of the Search 1 Pane. If you clear the selection of the check box, the search results will be displayed in the Search 1 Pane.
 - **Select Range** Check Box: If you select this check box, you can specify the search range by setting the start and end rungs.
3. Click the **Search Button** or the **Search All Button** to start searching.
If you click the **Search** Button, the instruction object that was found will be selected.
If you click the **Search All** Button, the search results will be displayed in the Search 1 or Search 2 Panes.

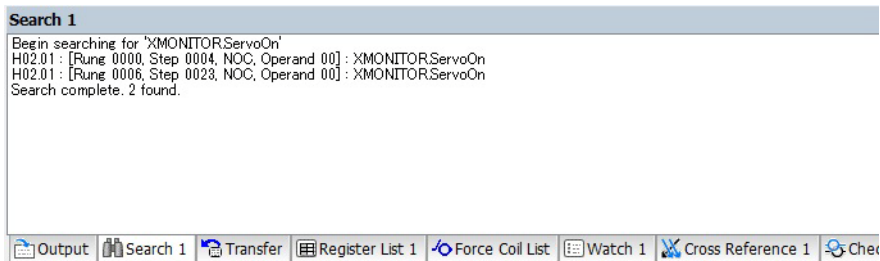

Replacing Text in Programs

1. Bring the program in which to search and replace to the front of the Ladder Editor, and then select **Edit – Replace** from the menu bar.
The Replace Dialog Box will be displayed.
2. Click the Variable or Comment/Bookmark Tab to set the search criteria and the replacement string.

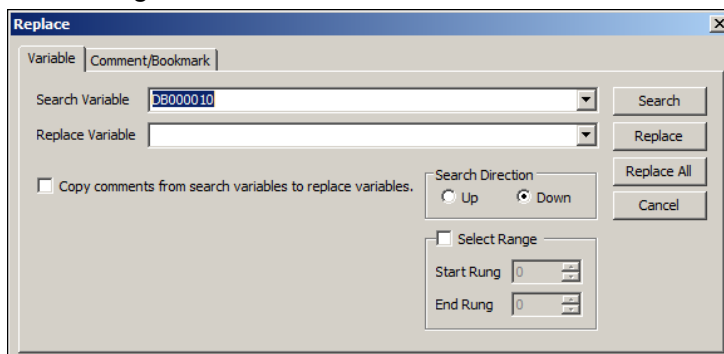

Variable Tab Page: Allows you to search for and replace variables.

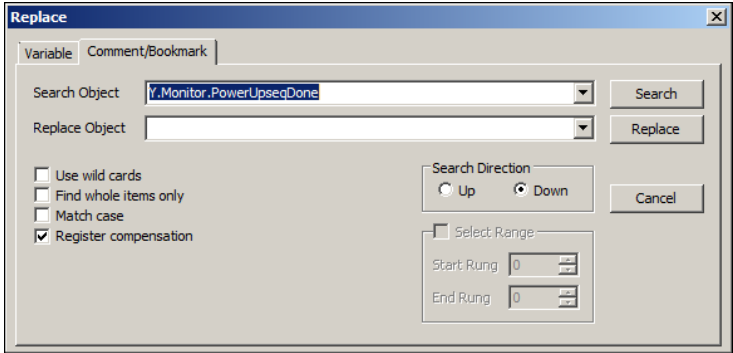

Comment/Bookmark Tab Page: Allows you to search for object comments, rung comments, program comments, expression comments, and bookmark.

- **Use wild cards** Check Box: Select this check box to use wildcard characters (* and ?) in the search string.
Note: If you enter an * or a ? character in the **Replace Object** Box, they will not be handled as wildcards, but as regular characters.
- **Select Range** Check Box: If you select this check box, you can specify the search range by setting the start and end rungs.
However, range selection is disabled on the Comment/Bookmark Tab Page.

3. Start the search/replace operation.

Click the **Search** Button. The instruction object that was found will be selected. If you click the **Replace** Button, the object will be replaced by the contents of the **Replace Register** or **Replace Object** Box.

If you click the **Replace All** Button on the Register Tab Page, the registers that are found will be replaced, and the replacement results will be displayed in the Output Pane.

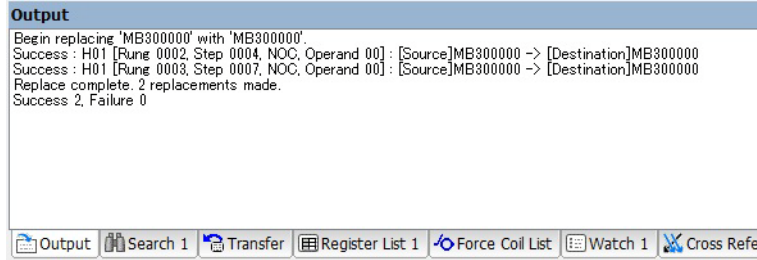

5.1.5 Searching and Replacing in Project Files

You can search for variables in all ladder programs, motion programs, and sequence programs, or in only the specified programs of a project file. You can also search for and replace registers and addresses.



Important You can search the project file only when the Machine Controller is offline.

The following section describes how to search for and replace text in a project file.

Searching in Project Files

1. Select **Edit – Search in Project** from the menu bar.
The Search in Project Dialog Box will be displayed.
2. Click the Variable, Instruction or Address Tab to set the search criteria and the replacement string.

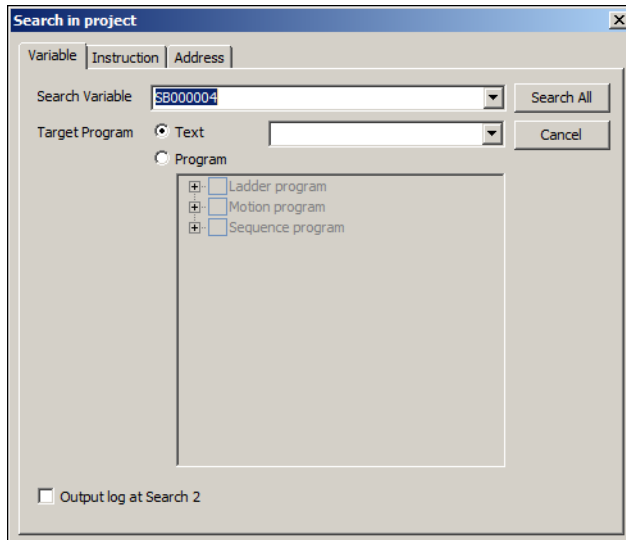

Variable Tab Page: Allows you to search for variables and registers. You can also enter the variable by copying it from the Variables Pane.

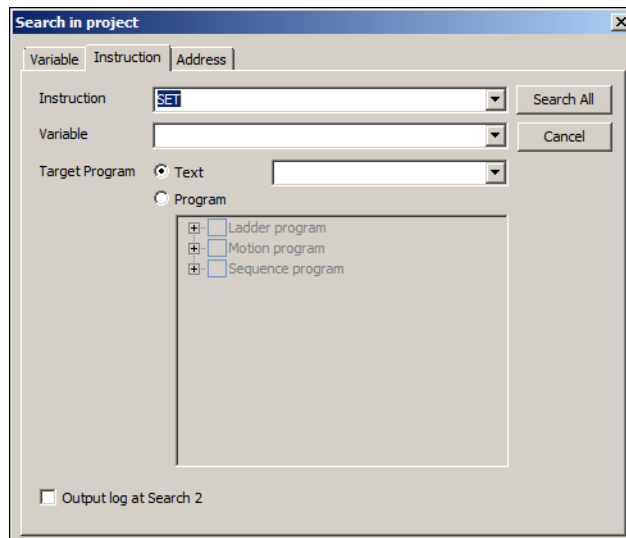

Instruction Tab Page: Enter the name of the instruction or the assigned instruction key in the **Instruction** Box.

The **Variable** Box is displayed when an instruction is entered in the **Instruction** Box. If the SEE instruction is entered in the **Instruction** Box, Variable changes to **Program Name**. You can also enter the **variable** by copying it from the Variables Pane.

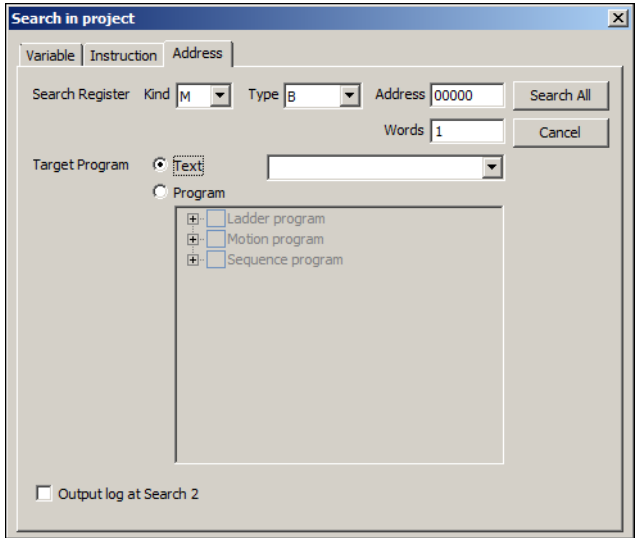

Address Tab Page: Allows you to replace registers that meet the specified criteria.

- Note:
1. Use commas and spaces to specify more than one program in the **Target Program** Box. The following wildcard (*) combinations can also be used in the **Target Program** Box: *, H*, L*, I*, A*, F* (all functions), MPM*, MPS*, SPM*, and SPS*. Other uses, such as "H01.*", are not allowed.
 2. **Output log at Search 2** Check Box: Select this check box to display the search results in the Search 2 Pane without changing the contents of the Search 1 Pane. If you clear the selection of the check box, the search results will be displayed in the Search 1 Pane.

3. Start the search operation.

Click the **Search All** Button. A progress bar will be displayed, and the search results will appear in the Search Pane.

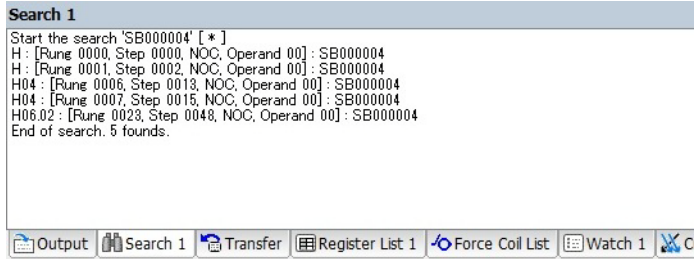

Replacing in Project Files



Important After you perform a replace operation on a project file, the project file will be compiled and saved, and there will be no way to return to the previous version. Always create a backup before performing replacements on important files.

1. Bring the program to search to the front of the Ladder Editor, and then select **Edit – Replace in the project** from the menu bar. The Replace in the Project Dialog Box will be displayed.
2. Specify the address of the variable to search for and the name of the program to search.

Note:

1. You can also enter the variable by copying it from the Variables Pane.
2. Use commas and spaces to specify more than one program in the **Target Program** Box. The following wildcard (*) combinations can also be used in the **Target Program** Box: *, H*, L*, I*, A*, F* (all functions), MPM*, MPS*, SPM*, and SPS*. Other uses, such as "H01.*", are not allowed.

3. Click the **Register** or **Address** Tab to set the search criteria and the replacement value.

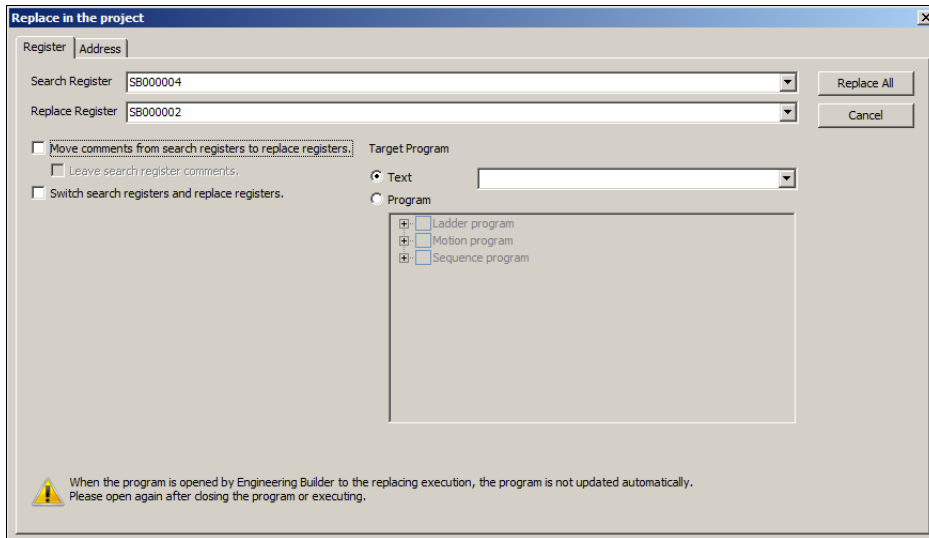

Register Tab Page: Allows you to replace registers.

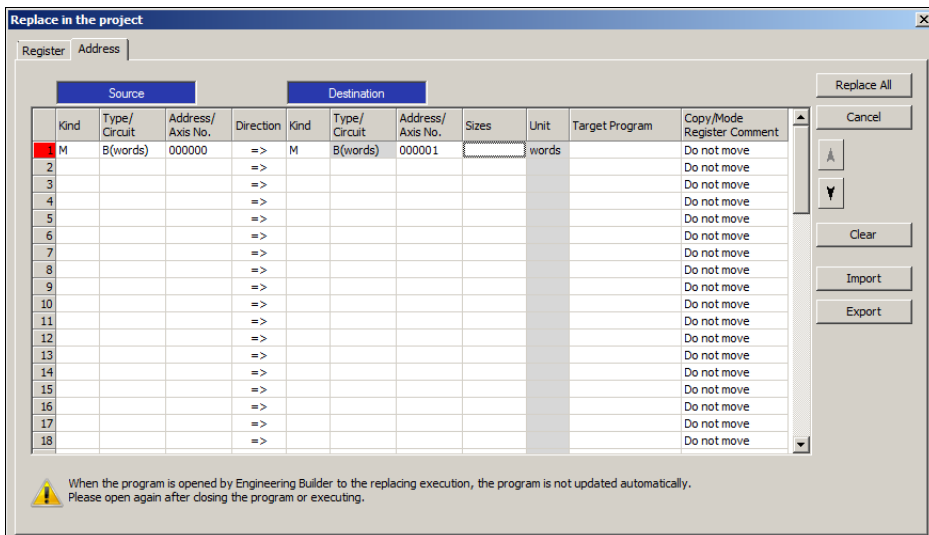

Address Tab Page: Allows you to replace registers that meet the specified criteria.

Note: The following wildcard (*) combinations can also be used in the **Target Program** Box:
, H, L*, I*, A*, F*, MPM*, and MPS*.

4. Start the search/replace operation.

Click the **Replace All** Button. The replacement results will be displayed in the Output Pane.

```

Output
Start the replace 'SB000004' is replace with 'SB000002'. [* ]
Success : H [Rung 0000, Step 0000, NOC, Operand 00] : [Source]SB000004 -> [Destination]SB000002
Success : H [Rung 0001, Step 0002, NOC, Operand 00] : [Source]SB000004 -> [Destination]SB000002
-----
Start compiling : H : Main Program
-----
warning C5001 : [Rung 0000, Step 00001, Operand 00] : DB0000000 is used with multiple coil.
warning C5001 : [Rung 0001, Step 00003, Operand 00] : DB0000000 is used with multiple coil.
Error 0 : Warning 2
End of replace. 2 founds.
Success 2, Failure 0
    
```

Note: If an error occurs during compilation of a program, the replacements will not be completed. After the replacement operation, the variables and addresses of the registers that were replaced will be displayed.

5.1.6 Cross Reference Panes

Cross referencing allows you to check whether a register is used in a program, and where it is used.

The search results indicate output registers in red, input registers in blue.

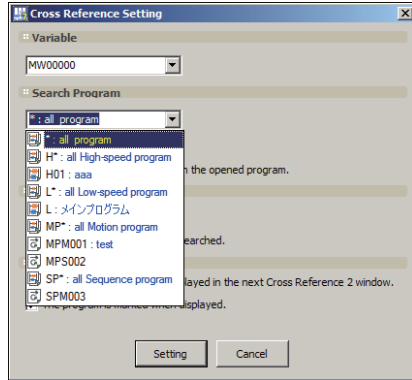

Cross referencing executed.

Search Results Display
Red: Output registers
Blue: Input registers

Cross Reference 1 [MW00000-* : All program / Search Result 6]						
Variable: MW00000		Search		Setting...		
Register	Program	Execution Instr...	Execution Step	Write/Read	Comm	
Same Register						
MW00000	H02: axis1	LOAD : Integer ...	0	Read		
MW00000	H02: axis1	STORE : Store	1	Write		
Same Memory Address						
MB000004	H02: axis1	NOC : NO Contact	2	Read		
MB000005	H02: axis1	COIL : Coil	3	Write		
ML00000	H03: axis2	LOAD : Integer ...	0	Read		
ML00000	H03: axis2	STORE : Store	1	Write		

If the value of a register is different from its set value, it means that the value of the register may have been overwritten somewhere in the program. In this case, you can search for the registers using cross references. Check the registers displayed in red, and locate the program that is overwriting them.

Example The following section describes the search operation on arrays.

1. Register[Register] Arrays

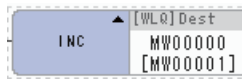

→ MW00000 and MW00001 are subject to searching.

2. Register[Constant] Arrays



→ MW00000 and MW00005 are subject to searching.

3. Register[Constant], LONG Arrays



→ ML00000 and ML00010 are subject to searching.

Refer to the following manual for details on the cross-reference operation procedure.

MP2000/MP3000 Series Engineering Tool MPE720 Version 7 User's Manual (Manual No.: SIEP C880761 03)

The following cross-reference criteria can be set. The following tables describe the check boxes.

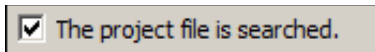



Check box	Search Method
Selected.	A search is made within the project file.
Not selected.	A search is made within the controller.



The local register is searched in the opened program.

Check box	Search Method
Selected.	A search is made for local registers (D registers) in the active drawing in the MPE720 Window within the project file.
Not selected.	A search is made for local registers (D registers) in the specified drawing within the controller.

The same register is searched.

Check box	Search Method
Selected.	A search is made for registers that are the same as the register that was found. Select this check box to display the results in a list when you search the following instructions for a variable of MW00000. 
Not selected.	A search is not made for the same register and data type as the register that was found. Clear the selection of this check box to not display the results in a list when you search the following instructions for a variable of MW00000. 

The same memory address is searched.

Check box	Search Method
Selected.	Searches for redundant addresses. Select this check box to display the results in a list when you search the following instructions with a variable with a different data type, such as ML00000. 
Not selected.	A search is not performed for redundant addresses. Clear the selection of this check box to not display the results in a list when you search the following instructions for a variable with a different data type, such as ML00000. 

5.1 Debugging Ladder Programs

5.1.6 Cross Reference Panes

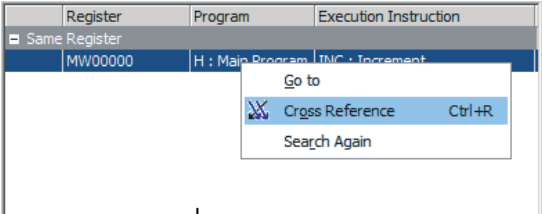
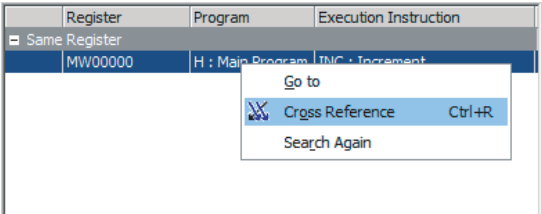
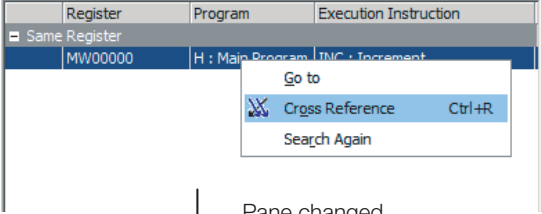
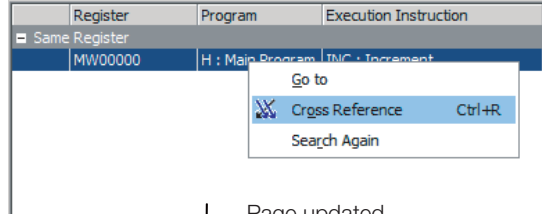
<input checked="" type="checkbox"/> The result of the search is displayed in the next Cross Reference 2 window.	
Check box	Search Method
Selected.	<p>When you perform cross referencing from the Cross Reference Pane, the results will be displayed in a separate pane. Cross reference results can be displayed in up to 3 panes.</p> <p>Cross Reference 1 Pane</p>  <p>↓ Pane changed.</p> <p>Cross Reference 2 Pane</p>  <p>↓ Pane changed.</p> <p>Cross Reference 3 Pane</p>  <p>Pane changed.</p>
Not selected.	<p>When you perform cross referencing from a Cross Reference Pane, the results will be displayed by updating the data in the same pane.</p> <p>Cross Reference 1 Pane</p>  <p>Page updated.</p>

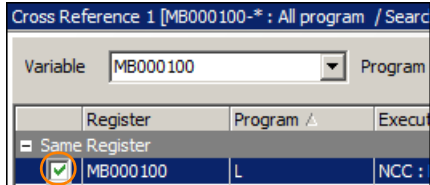
<input checked="" type="checkbox"/> The program is marked when displayed.	
Check box	Search Method
Selected.	<p>If you open a program by double-clicking after the search result is displayed, this check box will be automatically selected. This is a useful marker for making it easier to see which program was checked when there are multiple search results.</p> 
Not selected.	<p>Even if you open a program by double-clicking after the search results are displayed, this check box will not be automatically selected.</p>

5.1.7 Checking for Multiple Coils

You can check for multiple coils (different coils that use the same register) in the entire ladder program, and display the search results.

Information When you use a project link connection, the data in the project file is used. Sometimes the displayed results do not match the data in the linked Machine Controller. When you check for multiple coils and use a project link connection, first always read the data to the project file from the Controller.

Select **Debug – Check for Multiple Coils** from the menu bar.

Searching for multiple coils will start, and the results will be displayed in the Check for Multiple Coils Pane.

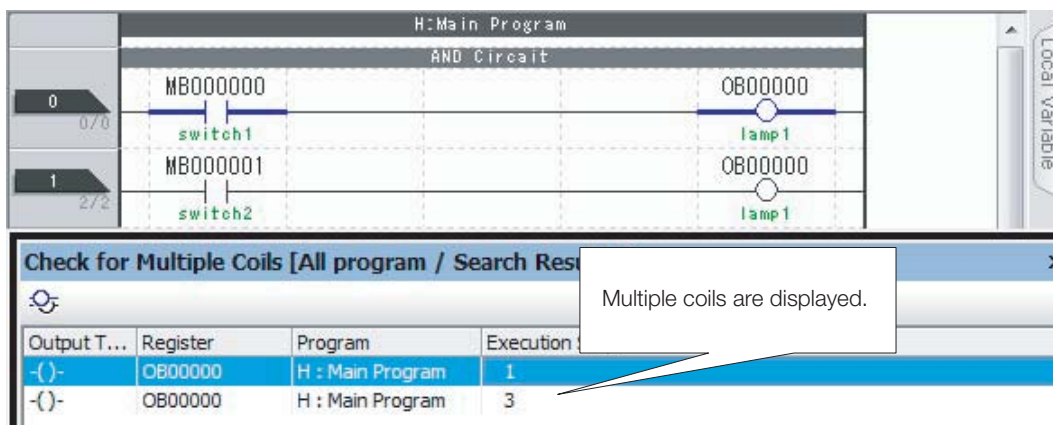

Information If the **Enable to Multiple Coil Check** Check Box is selected in the compile options, a search for multiple coils will be performed during compilation and the results will be displayed as warnings in the Output Pane.

5.1.8 Forcing Coils ON and OFF

This section describes how to force coils ON and OFF, and how to change the forced status.

Forcing Coils ON or OFF from a Ladder Program

You can monitor a program by forcing specified coil objects ON or OFF in the Ladder Editor.

1. Select the coil to force ON or OFF.
2. Select **Debug – Force OFF** from the menu bar.
The selected coil will be forced ON or OFF.

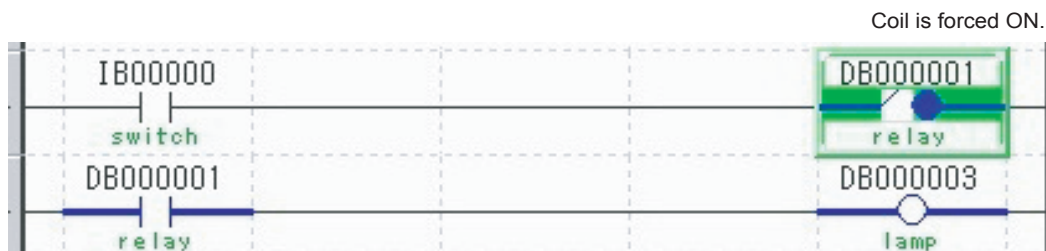

Information Select **Debug – Disable Force** from the menu bar to cancel forced ON or forced OFF status.

Changing the Forced ON/OFF Status from the Force Coil List Pane

The Force Coil List Pane lists the ON/OFF status of the forced coils in the ladder program. You can also change and cancel the ON, OFF, or canceled status of the forced coils in the entire ladder program.

◆ Searching for Forced Coils in the Force Coil List Pane

1. Display the Force Coil List Pane.

Note: You can show and hide the Force Coil List Pane by selecting **View – Other Windows – Force Coil List** from the menu bar.

2. Select **Debug – Force Coil List** from the menu bar.

Note: In the above case, all programs will be searched for forced coils. To specify a program for the search, press the **Force Coil Condition Setting** Button  to display the Force Coil Condition Setting Dialog Box.

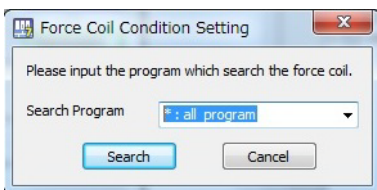

The search results will be displayed in the Force Coil List Pane.

Forcing ...	Coil	Prog...	Variable	Comment	Execution Step
<input type="checkbox"/> ON	/ (ON)-	H : ...	MB000100	Runswitch	1
<input checked="" type="checkbox"/> OFF	/ (OFF)-	H : ...	MB000100	Runswitch	3
<input checked="" type="checkbox"/> ON	/ (ON)-	H : ...	MB000100	Runswitch	5
<input checked="" type="checkbox"/> OFF	/ (OFF)-	H : ...	MB000100	Runswitch	7
<input type="checkbox"/> ON	/ (S ON)-	H01 ...	MB000200	Axial alarm...	1
<input type="checkbox"/> OFF	/ (R OFF)-	H01 ...	MB000200	Axial alarm...	3

3. Select the check boxes for the coils to force ON or OFF.

Forcing ...	Coil	Prog...	Variable	Comment	Execution Step
<input type="checkbox"/> ON	/ (ON)-	H : ...	MB000100	Runswitch	1
<input checked="" type="checkbox"/> OFF	/ (OFF)-	H : ...	MB000100	Runswitch	3
<input checked="" type="checkbox"/> ON	/ (ON)-	H : ...	MB000100	Runswitch	5
<input checked="" type="checkbox"/> OFF	/ (OFF)-	H : ...	MB000100	Runswitch	7
<input type="checkbox"/> ON	/ (S ON)-	H01 ...	MB000200	Axial alarm...	1
<input type="checkbox"/> OFF	/ (R OFF)-	H01 ...	MB000200	Axial alarm...	3

Information

1. If you right-click in the Force Coil List Pane, you can use the pop-up menu to select **Check All** or **Uncheck All** to select or clear the selections of the all of the **Forcing** Check Boxes.
2. If you select or double-click a search result row in the Force Coil List Pane, you can jump to the corresponding coil in the ladder program. Alternatively, you can right-click in the list in the Force Coil List Pane, and select **Jump** from the pop-up menu. If the program is not open, it will be opened automatically and the display will jump to the corresponding coil in the program.
3. If you right-click in the Force Coil List Pane and select **Cross Reference** from the pop-up menu, or select **Debug – Cross Reference** from the menu bar, the register that is set for the coil will be checked for cross references and the results will be displayed in the Cross Reference Pane.
4. If you edit the ladder program while the search results are displayed, the coils in the edited program will be displayed in gray.

◆ Names and Descriptions of the Force Coil List Pane Items

The Force Coil List Pane consists of a list where the forced coils are displayed, and a toolbar that is used to search and repeat searches for forced coils, and to change the forced status of coils.

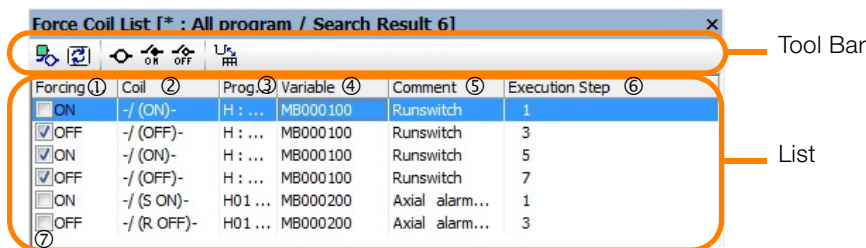

■ Tool Bar

• Force Coil Condition Setting Button (🔍)

Click this button to display the Force Coil Condition Setting Dialog Box. Specify the program to search for forced coils.

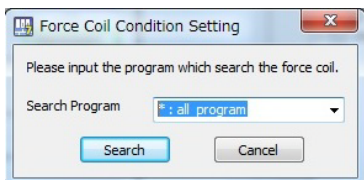

• Repeat Search Button (🔄)

Click this button to repeat the forced coil search in the program that was specified in the Force Coil Condition Setting Dialog Box.

• Cancel Forcing Button (🚫)

Click this button to cancel the forced status of the selected coils.

• Force ON Button (👆)

Click this button to force ON the selected coils.

• Force OFF Button (👇)

Click this button to force OFF the selected coils.

• Variable Display Switch Button (📄)

Click this button to switch the display of the register that is used by the coil between a register or a variable.

■ List

① Forcing Status

This column displays the forced ON or OFF status of the coils that were found.

② Coil

This column displays the coils that were found.

There are six types of coils.

Coil Type	Coil Symbol	
	ON	OFF
Coil	-/ (ON)-	-/ (OFF)-
Set Coil	-/ (S ON)-	-/ (S OFF)-
Reset Coil	-/ (R ON)-	-/ (R OFF)-

③ Programs

This column displays the names of the programs where the coils were found.

④ Variable

This column displays the variables or registers that are set for the coils that were found.

⑤ Comment

This column displays the comments of the variables.

⑥ Execution Step

This column displays the execution step numbers of the coils that were found.

⑦ Check Boxes

The coils with selected check boxes will be subject to forcing operations (ON, OFF, or Cancel). You can use the toolbar buttons and also the pop-up menu to force the status of all selected coils to ON, OFF, or canceled.

5.1.9 Viewing a Called Program

You can open a drawing that is called with a Call Program (SEE) instruction or a User Function (FUNC) instruction.

Select the SEE instruction object or FUNC instruction object for the program to view, and select **Debug – Open Program** from the menu bar.

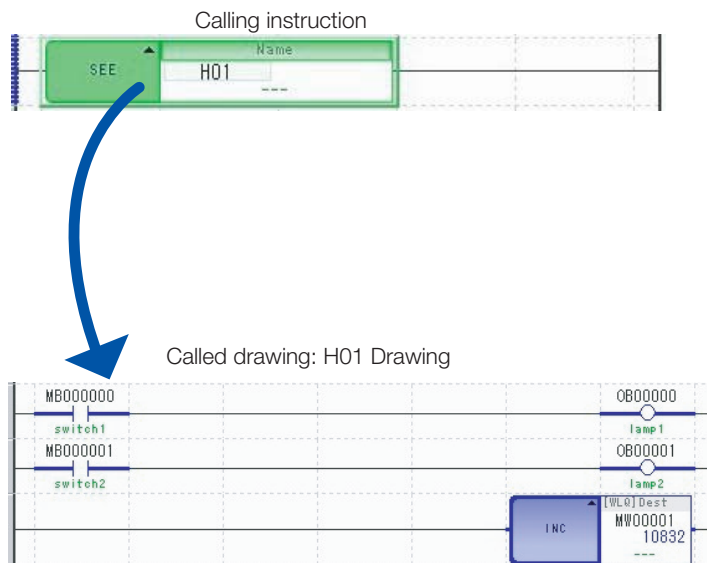

5.1.10 Enabling and Disabling a Program

A program drawing can be disabled to temporarily prevent the program from being executed. Right-click the **Program** Icon in the Ladder Pane, and select **Enable** or **Disable**.

5.2 Debugging a Motion or a Sequence Program

This section describes how to execute programs in Debug Operation Mode.

The Debug Operation Mode allows you to monitor the line of the motion or sequence program that is current being executed. This makes it easier to find bugs in the program.

You can pause the execution of a program, set breakpoints, perform single-step execution (single-block execution), and perform other operations to ensure proper operation of the program that you developed.

In Debug Operation Mode, the program line that is being executed is displayed at the top of the tab page as shown below.

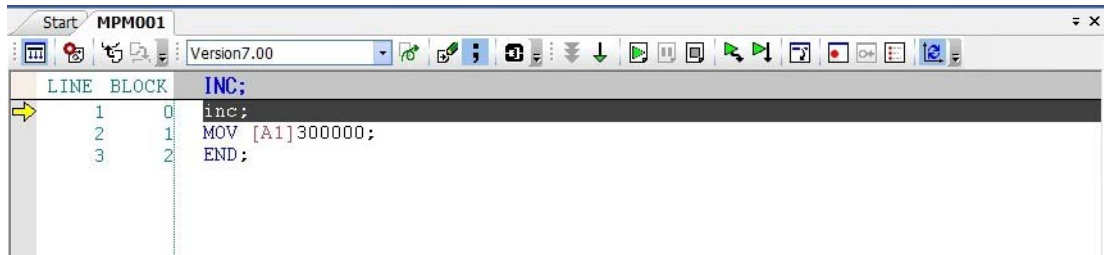

To start Debug Operation Mode, first connect to the Controller, then click the  icon on the Motion Editor Tab Page.

In Debug Operation Mode, the program line that is being executed is highlighted at the top of the tab page.

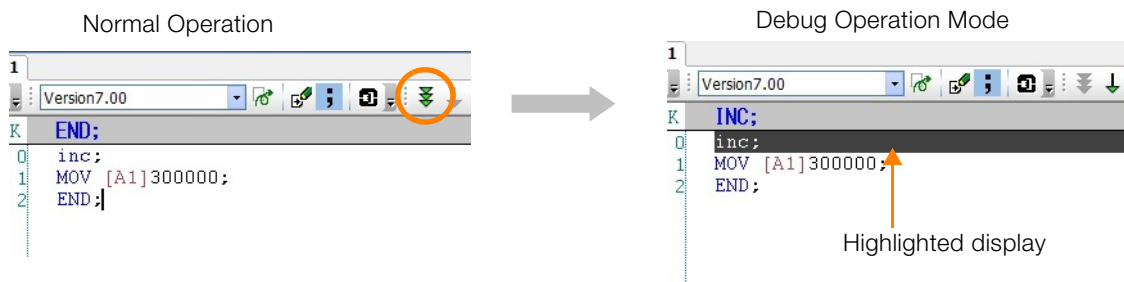

Information You must register the program for execution before you can start Debug Operation Mode.

5.2.1 Tab Page Items

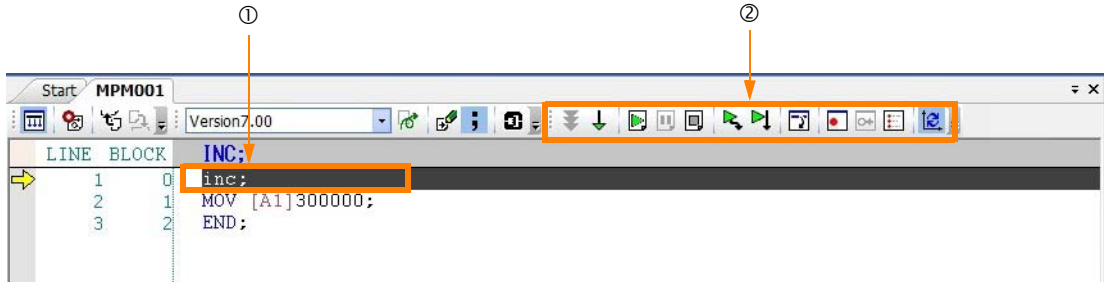

① Current Program Line

The program line that is currently being executed is displayed in blue.

If an alarm has occurred in the motion program, the line will be displayed in red. Refer to the following manuals for details on motion program alarms.

MP2000 Series User's Manual for Motion Programming (Manual No.: SIEP C880700 38)

MP2000 Series Troubleshooting Manual (Manual No.: SIEP C880700 40)

② Toolbar Icons and Function Keys

The following table describes the icons and function keys that are used in Debug Operation Mode.

Function	Icon	Key Operation	Description	Motion Programs	Sequence Programs
Debug Operation Mode		F1	Starts Debug Operation Mode.	○	○
Normal Operation Mode		F11	Ends Debug Operation Mode and starts the continuous execution of the program in Normal Operation Mode.	○	○
Move Start Point		F6	Moves the start point for execution.	○	○
Breakpoint Set/Remove		F7	Sets or removes a breakpoint. Displays the breakpoints in the program.	○	○
Step In		F4	Executes one block. For an MSEE or SSEE instruction, debugging will move to the first line of the subprogram.	○	○
Step Over		F5	Executes one block. For an MSEE or SSEE instruction, the subprogram will be executed and debugging will continue at the next block after the MSEE or SSEE instruction.	○	○
Execute		F8	Continuously executes a motion program in Debug Operation Mode.	○	○
Break		F10	Pauses the execution of a motion program in Debug Operation Mode.	○	○
End		F2	Ends execution of the motion program.	○	×
Update Current Position		-	Updates the current position coordinates.	○	×
Set Motion Task		-	Sets the fork number, level number, and task of the selected program.	○	○
Breakpoint Enable/Disable	-	-	Enables or disables breakpoints. Use the Debug Menu or the pop-up menu for this setting.	○	○

Note: O: Possible, x: Not possible.

5.2.2 Monitoring Program Execution

You can monitor the lines of the program that are currently being executed to debug the program more easily.

You can use the Drive Control Panel to monitor the execution and debug the program.

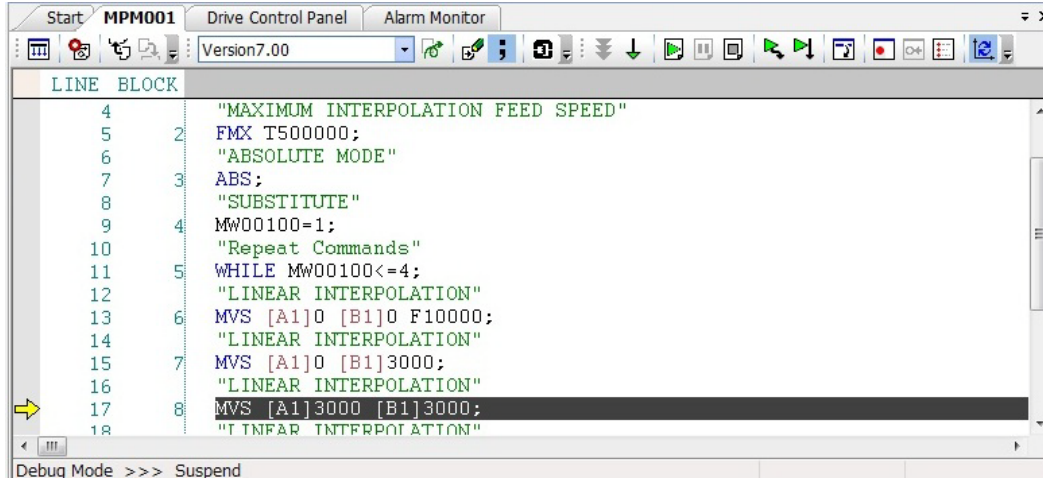

There are two modes for debugging and monitoring: Debug Operation Mode and Normal Operation Mode.

Debug Operation Mode

This mode executes the program one line at a time. While in Debug Operation Mode, you can check the operation status of the program in the Drive Control Panel.

Normal Operation Mode

This mode executes the program continuously from the beginning to the end. You can monitor the block lines one by one.

◆ Block Monitor Tab Page

The line that is currently being executed is highlighted.



■ Monitoring Subprograms

You must set a motion task for the subprogram in advance.

You cannot monitor a subprogram without a motion task setting.

■ Monitoring Sequence Programs

The Block Monitor Tab Page is displayed for sequence programs only if they are executed in Debug Operation Mode.

■ Monitoring Programs That Are Being Edited

If you edit the program while it is executed in monitoring mode, the Block Monitor Tab Page will change in the following way:

- If you edit the program, the Block Monitor Tab Page will disappear.
- After you edit and compile the program, the Block Monitor Tab Page will be displayed.

Alarm Indications

If an alarm occurs in the motion program during execution, the line that is being executed will be displayed in red.

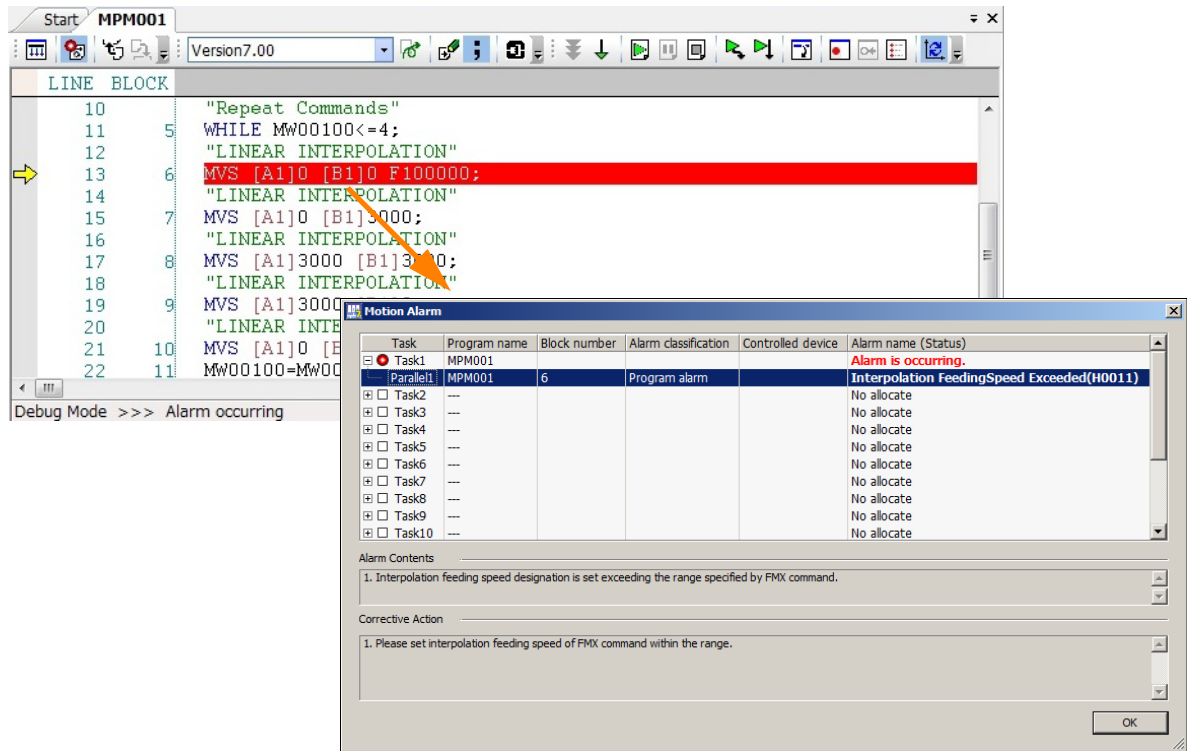

5.2.3 Register List Panes

You can display a register list in the same way as you can when you debug a ladder program. Refer to the following section for details.

5.1 Debugging Ladder Programs – Register List Panes (page 5-4)

5.2.4 Watch Panes

You can monitor the values and comments of the specified S, I, O, M, C, D, and G registers in the Watch 1, 2, and 3 Panes. Refer to the following section for details.

5.1 Debugging Ladder Programs – Watch Panes (page 5-7)

5.2.5 Searching and Replacing in Programs

You can search and replace text in the same way as you can for ladder programs.

Refer to the following section for details.

5.1 Debugging Ladder Programs – Searching and Replacing in Programs (page 5-8)

5.2.6 Searching and Replacing in Project Files

You can search and replace text in the same way as you can for ladder programs. Refer to the following section for details.

5.1 Debugging Ladder Programs – Searching and Replacing in Project Files (page 5-10)

5.2.7 Viewing a Motion Subprogram

You can open and view a program that is called with an MSEE instruction.

1. Select the MSEE instruction for the drawing with the program to view, then select **Debug – Refer** from the menu bar.
2. The called program will be displayed in the Edit Tab Page.

5.2.8 Cross Reference Searches

You can search and replace text in the same way as you can for ladder programs. Refer to the following section for details.

 5.1 Debugging Ladder Programs – Cross Reference Panes (page 5-14)

5.2.9 Alarm Monitor

Use this dialog box to check any alarms that occur during motion program execution.

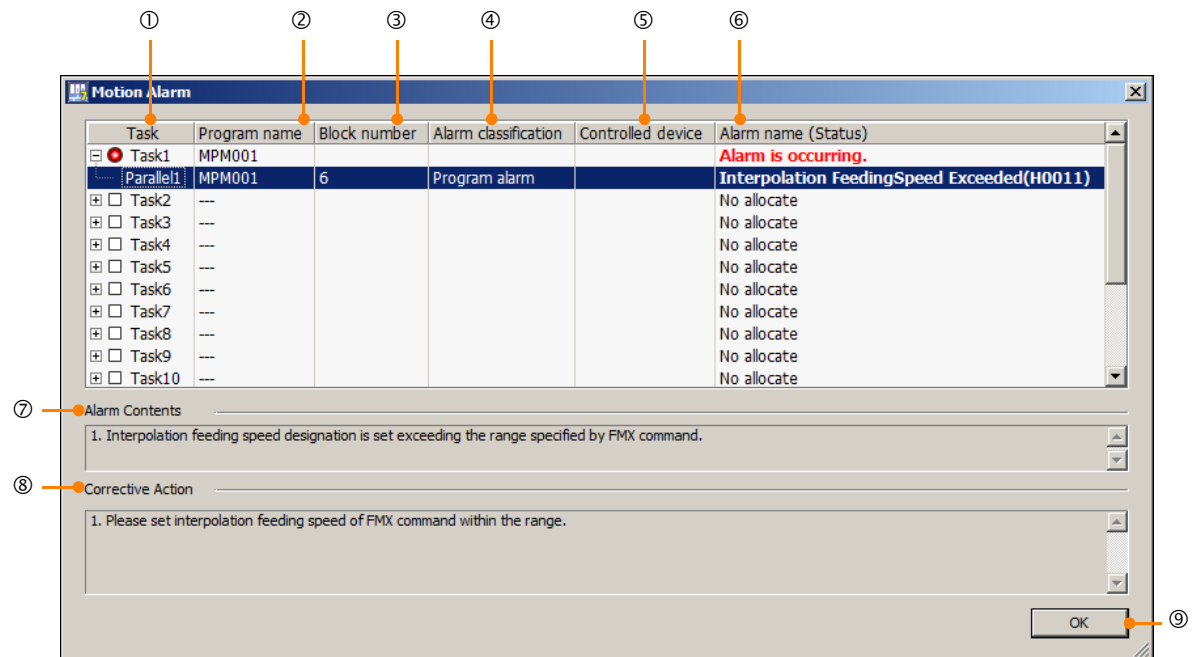

No.	Name	Description
①	Task	Displays the task numbers.
②	Program name	Displays the program numbers.
③	Block number	Displays the block numbers where the alarms occurred.
④	Alarm classification	“Program alarm” or “Axis alarm” is displayed.
⑤	Controlled device	The name of the logical axis (circuit, axis number) determined in the group definition of the motion program is displayed.
⑥	Alarm name (Status)	Displays the names of the alarms.
⑦	Alarm Contents	This box displays a description of the alarm.
⑧	Corrective Action	This box displays information on correcting the condition that caused the alarm.
⑨	OK	The OK Button closes the Motion Alarm Dialog Box and returns to the Motion Editor Tab Page.

Checking Alarm Codes

When a motion program alarm occurs (i.e., when status bit 8 (Active Program Alarm) turns ON), the cause of the alarm is reported in the alarm code.

The motion program alarm codes can be checked using the Motion Alarm Dialog Box or the S registers.

◆ Motion Alarm Dialog Box

To display the Motion Alarm Dialog Box, monitor the motion program online, and double-click the program line displayed in red.

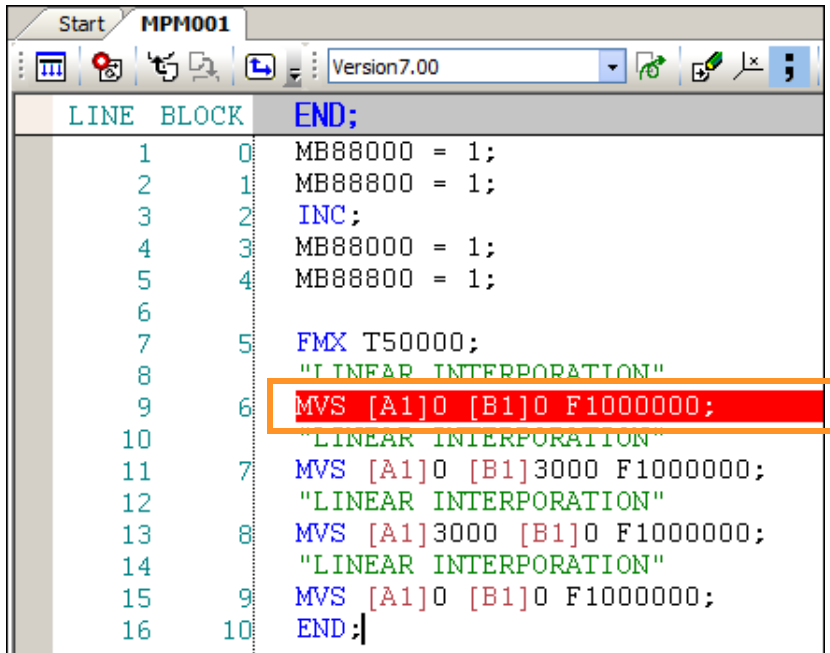

The following Dialog Box is displayed.

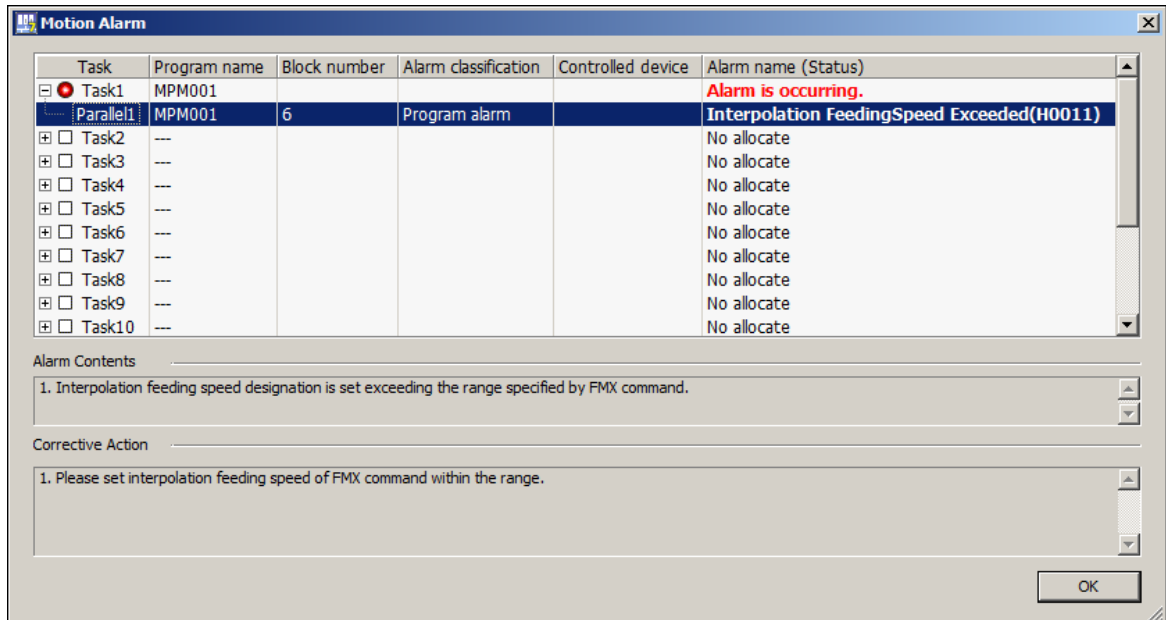

◆ S Registers

Refer to the following manuals for information on checking the alarm codes in the S registers.

MP2000 Series User's Manual for Motion Programming (Manual No.: SIEP C880700 38)

MP2000 Series Troubleshooting Manual (Manual No.: SIEP C880700 40)

5.2.10 Alarm Code Details

This section describes the alarm codes that are used in motion programs.

Structure of Motion Program Alarms

The following figure shows the structure of the alarm codes.

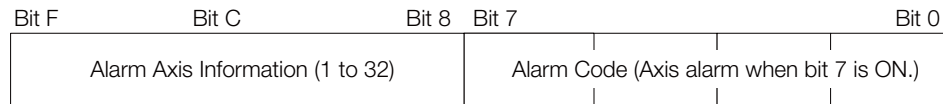

Motion Program Alarm Codes

The following table lists the alarm codes for motion programs.

Alarm Code	Alarm Name	Alarm Description	Corrective Action
02 hex	Division error	The data was divided by 0.	Correct the motion program.
10 hex	Turn specified instead of radius	A number of turns (T) was specified instead of a radius for a circular or helical interpolation instruction.	<ul style="list-style-type: none"> Convert the radius setting to a center point coordinate setting to execute the circular or helical interpolation instruction. Do not specify a number of turns.
11 hex	Interpolation feed speed over limit	The interpolation feed speed setting exceeded the setting range of the FMX instruction.	Correct the feed speed setting of the interpolation instruction.
12 hex	No interpolation feed speed setting	The interpolation feed speed has never been set. (If you set it once, further settings can be omitted within the same program.)	Set the feed speed using the interpolation instruction.
13 hex	Range exceeded after acceleration parameter conversion	The indirectly designated acceleration parameter exceeded the setting range.	Change the value of the register that is used for the indirect designation.
14 hex	Circular arc length exceeded LONG_MAX	The circular arc length that was specified for a circular or helical interpolation instruction exceeded the setting range.	Correct the circular arc length setting for the circular or helical interpolation instruction.
15 hex	No vertical axis set for the circular arc plane	The vertical axis was not set for a circular or helical interpolation instruction.	Set the axis with the PLN instruction.
16 hex	No horizontal axis set for the circular arc plane	The horizontal axis was not set for a circular or helical interpolation instruction.	Set the axis with the PLN instruction.
17 hex	Number of axes over limit	The number of specified axes exceeds the limit of a circular interpolation instruction (2 axes max.) or a helical interpolation instruction (3 axes max.).	Correct the axis setting of the circular or helical interpolation instruction.
18 hex	Number of turns over limit	The number of turns that was specified for a circular or helical interpolation instruction exceeded the setting range.	Correct the number of turns setting of the circular or helical interpolation instruction.
19 hex	Radius exceeded LONG_MAX	The radius that was specified for a circular or helical interpolation instruction exceeded the setting range.	Correct the radius setting for the circular or helical interpolation instruction.
1A hex	Center point setting error	The correct point was not set for a circular or helical interpolation instruction.	Specify a correct center point for the circular or helical interpolation instruction.

Continued on next page.

Continued from previous page.

Alarm Code	Alarm Name	Alarm Description	Corrective Action
1B hex	Emergency stop	The axis movement instruction was stopped due to a Request for Stop of Program.	Turn OFF the Request for Stop of Program motion program control signal, and turn ON the Alarm Reset Request.
1C hex	Linear interpolation travel distance exceeded LONG_MAX	The travel distance that was specified for a linear interpolation instruction exceeded the setting range.	Correct the travel distance for the linear interpolation instruction.
1D hex	FMX is not defined	There was no FMX instruction executed in a motion program that includes an interpolation instruction.	Execute an FMX instruction. An FMX instruction is required for each program that contains an interpolation instruction.
1E hex	T address out of range	The address setting in an IAC/IDC/FMX instruction exceeds the setting range.	Correct the setting in the IAC/IDC/FMX instruction.
1F hex	P address out of range	The address setting in an IFP instruction exceeds the setting range.	Correct the setting in the IFP instruction.
21 hex	PFORK execution error	Motion instructions were executed at the same time in the second fork of the PFORK instruction in the calling motion program and the second fork of the PFORK instruction in the subprogram.	Correct the motion program or the subprogram.
22 hex	Indirect designation register range error	The specified register address exceeds the range of the register size.	Correct the motion program.
23 hex	Travel distance out of range	The decimal-format axis travel distance specified in an axis movement instruction exceeds the allowed range.	Correct the axis travel distance.
24 hex	Interpolation override out of range	The interpolation override setting exceeded the setting range.	Correct the Interpolation Override Setting.
26 hex	PFORK number of parallel forks error	The number of parallel forks exceeded the number set for the parallel mode.	<ul style="list-style-type: none"> • Correct the motion program. • Correct the parallel mode setting.
80 hex	Logical axis use prohibited	More than one motion instruction was executed for the same axis.	Correct the motion program.
81 hex	The infinite length axis setting exceeded POSMAX	The travel distance setting for infinite length axis exceeded the POSMAX setting.	<ul style="list-style-type: none"> • Set the Infinite Length Axis Reset Position fixed parameter. • Correct the motion program.
82 hex	The axis travel distance exceeded LONG_MAX	The axis travel distance setting exceeded the allowed range.	Correct the motion program.
84 hex	Duplicated motion command	More than one instruction was executed for the same axis.	Check to see if a reference for the same axis is being issued from any other program. If it is, correct the program.
85 hex	Motion command response error	A response for a different motion command was reported by the Motion Module when a motion instruction was executed.	<ul style="list-style-type: none"> • Remove the cause of the alarm at the target axis. • If the Servo is not ON, turn ON the Servo. • Check to see if a reference for the same axis is being issued from any other program. If it is, correct the program.
87 hex	VEL setting out of range	The setting in the VEL instruction exceeds the allowed range.	Correct the VEL instruction.
88 hex	INP setting out of range	The setting in the INP instruction exceeds the allowed range.	Correct the INP instruction.

Continued on next page.

Continued from previous page.

Alarm Code	Alarm Name	Alarm Description	Corrective Action
89 hex	ACC/SCC/DCC setting out of range	The setting in the ACC/SCC/DCC instruction exceeds the allowed range.	Correct the ACC/SCC/DCC instruction.
8A hex	No time setting in MVT instruction	The T setting in the MVT instruction is zero.	Correct the MVT instruction.
8B hex	Command cannot be executed	The specified motion instruction cannot be executed on the target Motion Module.	Correct the motion program.
8C hex	Distribution incomplete	A motion instruction was executed when the Motion Module has not completed distribution for a previous instruction.	Correct the motion program so that the motion instruction is executed when the Distribution Completed Bit is ON.
8D hex	Motion command error termination	The Motion Module is in Command Error status.	<ul style="list-style-type: none"> • Clear the error at the target axis. • Correct the motion program.

5.3 Monitoring Machine Operation

This section describes how to monitor a machine that is connected to the Machine Controller.

5.3.1 Axis Monitor

You can monitor the operating status for each axis that is connected to the Machine Controller. You can display the operating status of the axes and the data of other monitor parameters.

Information You can use the Axis Monitor Tab Page to check the Ready/Servo ON status (“Ready/Servo Enable”), the Alarm/Warning status, the Distribution/Positioning Completed (“Prof. Comp/In Position”) status, and the motion command.

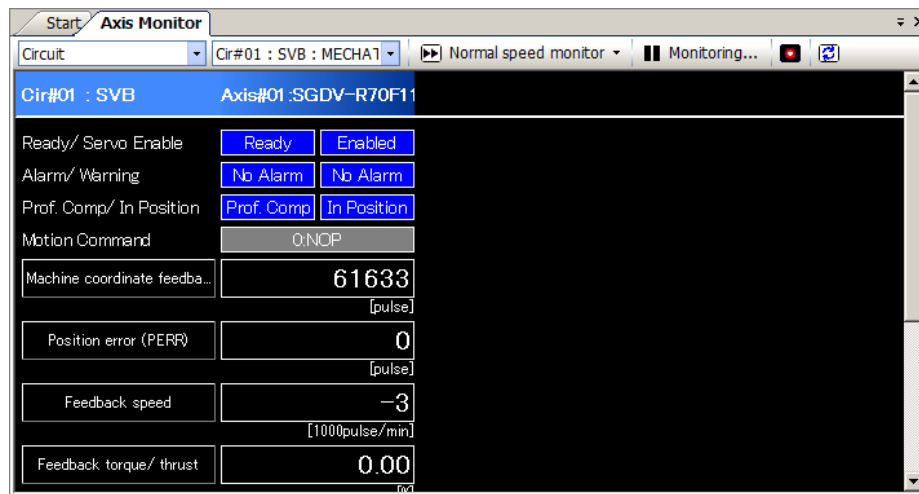

Starting the Axis Monitor

Double-click **Axis configuration – Axis Monitor** in the System Pane of MPE720 version 7. Alternatively, click the **Axis Monitor** Button in the My Tool Tab Page.

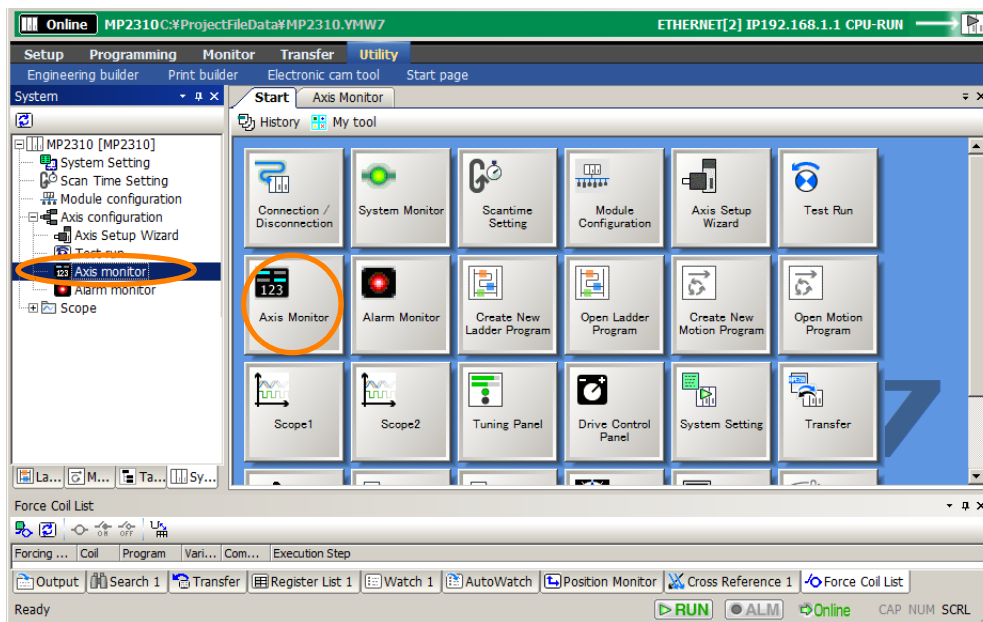

Names and Functions of the Axis Monitor Tab Page Items

The following figure shows the items that are displayed on the Axis Monitor Tab Page.

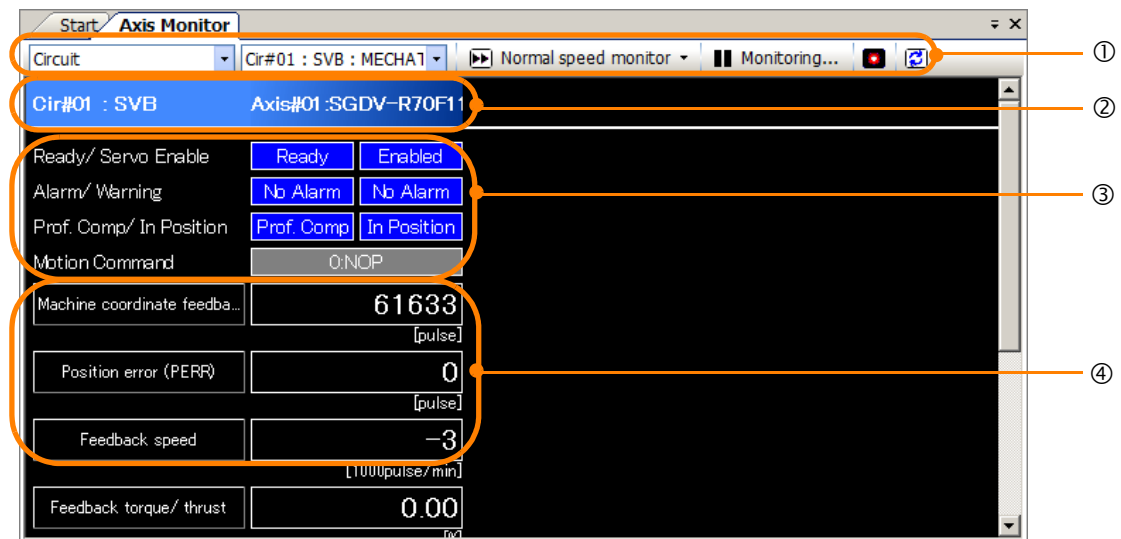

No.	Item	Function
①	Tool Bar	Use the toolbar to update the display or stop the monitor.
②	Circuit and axis display	Displays the circuit number and the axis name.
③	Axis operating status display	Displays the operating status of the axis.
④	Monitor parameter display	Displays the names and current values of the monitor parameters.

Information

The following axes can be displayed for the given Modules.

- SVC or SVC32: The axes connected to the MECHATROLINK
- SVC-01: The axes connected to the MECHATROLINK
- SVB Module: The axes connected to the MECHATROLINK
- SVA-01: 2 axes
- SVR: 16 axes
- PO-01: 4 axes

The following section gives detailed information on each item.

■ Tool Bar

The toolbar contains icons for selecting the circuit, changing the monitoring speed, and controlling the display.

Icon	Name	Function
	Circuit selection	Selects the circuit to monitor.
	Monitor type	Selects the monitoring frequency from the following three options: • High-speed monitor • Normal-speed monitor • Low-speed monitor
	Stop monitor	Stop monitor: Stops the monitor.
	Start monitor	Monitoring: The monitor is operating.
	Alarm Monitor	Display the Alarm Monitor.
	Refresh	Updates the information on the Axis Monitor Tab Page.

■ Circuit and Axis Display

This area displays the circuit number of the Module that is connected to the Machine Controller, the name of the Motion Module (SVA-01, SVB/SVB-01, or SVC-01), and the name of the axis connected to the Motion Module.

You can select a Module from the list to display the Axis Monitor for another Module.

■ **Axis Display**

This area displays the axis number, the axis type, and the comment (if there is one) for the axis.

■ **Displaying the Operating Status of the Axis**

This area displays the operating status of the axis. You can use this area to check the Ready/Servo ON status (“Ready/Servo Enable”), the Alarm/Warning status, the Distribution/Positioning Completed (“Prof. Comp/In Position”) status, and the motion command.

• **Ready/Servo ON (“Ready/Servo Enable”)**

This row displays whether the axis is in ready status and whether it is in Servo ON (“Enabled”) status.

Icon	Name	Function
<div style="background-color: blue; color: white; padding: 2px; text-align: center;">Ready</div> <div style="background-color: gray; color: white; padding: 2px; text-align: center;">Not Ready</div>	Ready	Ready: Preparations for axis operation have been completed. Not Ready: Preparations for axis operation have not been completed.
<div style="background-color: blue; color: white; padding: 2px; text-align: center;">Enabled</div> <div style="background-color: gray; color: white; padding: 2px; text-align: center;">Disabled</div>	Enabled	Enabled: The Servo is ON. Disabled: The Servo is OFF.

• **Alarms/Warnings**

This row is displayed if an alarm or warning has occurred.

Icon	Name	Function
<div style="background-color: red; color: white; padding: 2px; text-align: center;">Alarm</div>	Alarm	An alarm has occurred.
<div style="background-color: yellow; color: black; padding: 2px; text-align: center;">Warning</div>	Warning	A warning has occurred.

To see details on the alarm or warning, click the status indicator to display the Alarm/Warning Dialog Box.

When the alarm/warning condition has been corrected, the status will change in the following way:

Icon	Name	Function
<div style="background-color: blue; color: white; padding: 2px; text-align: center;">No Alarm</div>	No Alarm	There is no alarm or warning.

• **Distribution/Positioning Completed (“Prof. Comp/In Position”)**

This row displays the status of the Distribution Completed and Positioning Completed bits in the Position Management Status parameter. A blue background indicates that the status bit is ON.

Icon	Name	Function
<div style="background-color: blue; color: white; padding: 2px; text-align: center;">Prof. Comp</div> <div style="background-color: gray; color: white; padding: 2px; text-align: center;">Prof. Comp</div>	Pulse Distribution Completed (“Prof. Comp”)	This box displays the status of the Distribution Completed bit.
<div style="background-color: blue; color: white; padding: 2px; text-align: center;">In Position</div> <div style="background-color: gray; color: white; padding: 2px; text-align: center;">In Position</div>	Positioning	This box displays the status of the Positioning Completed bit.

• **Motion Command**

This row displays the status of the motion command response code. The background is blue whenever there is a command of any type.

Setting and Displaying Monitor Parameters

You can check the contents of the monitor parameters that are displayed in the Module Configuration Definition.

You can monitor up to eight monitor parameters at the same time.

You can set the parameters to monitor by selecting them from the list, or by entering I/O motion registers directly.

You can also change the previously set monitor parameters.

Information The monitor parameters that you set are saved as setting information, so when you reopen the Axis Monitor Tab Page the next time, the previously set monitor parameters will be displayed.

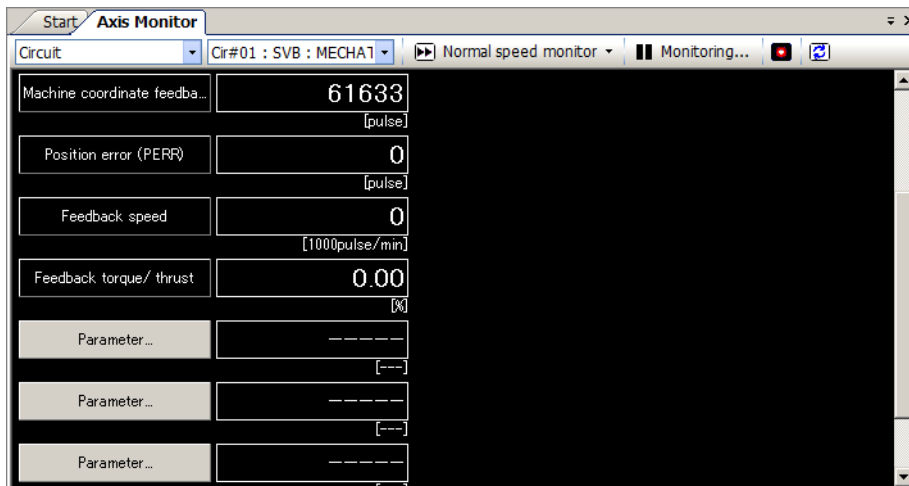

Use the following procedure to select the monitor parameters.

1. Click a monitor parameter that is already displayed, or click the Parameter Selection () Button.
The Motion Parameter Dialog Box will be displayed.
2. Select the parameters to monitor from the list, or enter I/O motion registers directly.

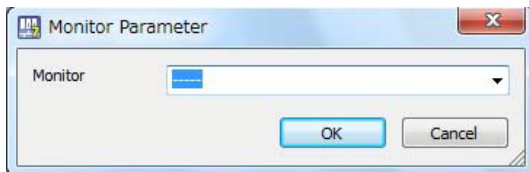

The following monitor parameters are displayed in the box list:

Monitor Parameter	Register	Unit
Machine Coordinate System Target Position (TPOS)	IL□□□0E	Reference units
Machine Coordinate System Calculated Position (CPOS)	IL□□□10	Reference units
Machine Coordinate System Reference Position (MPOS)	IL□□□12	Reference units
Machine Coordinate System Feedback Position (APOS)	IL□□□16	Reference units
Machine Coordinate System Latch Position (LPOS)	IL□□□18	Reference units
Position Deviation (PERR)	IL□□□1A	Reference units
Number of POSMAX Turns	IL□□□1E	rev
Speed Reference Output Monitor	IL□□□20	pulses/s ("pulse/sec")
Feedback Speed	IL□□□40	Speed Unit Selection
Torque/Force Reference Monitor	IL□□□42	Torque Unit Selection

5.3.2 Alarm Monitor

The Alarm Monitor monitors all axes that are connected to the Machine Controller. This tab page displays the alarm and warning status of each axis.

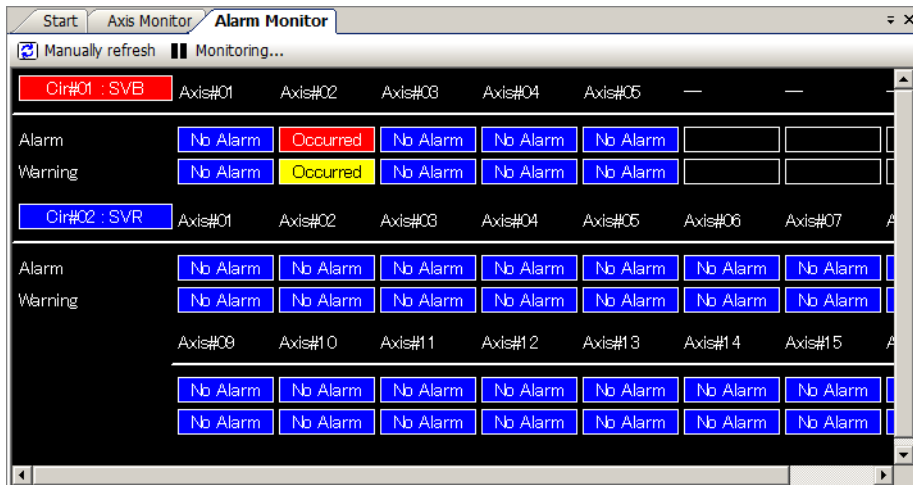

Starting the Alarm Monitor

Double-click **Axis configuration – Alarm Monitor** in the System Pane of MPE720 version 7. Alternatively, click the **Axis Monitor** Button on the My Tool Tab Page, or click the **Alarm Monitor** Button in the Axis Monitor Tab Page.

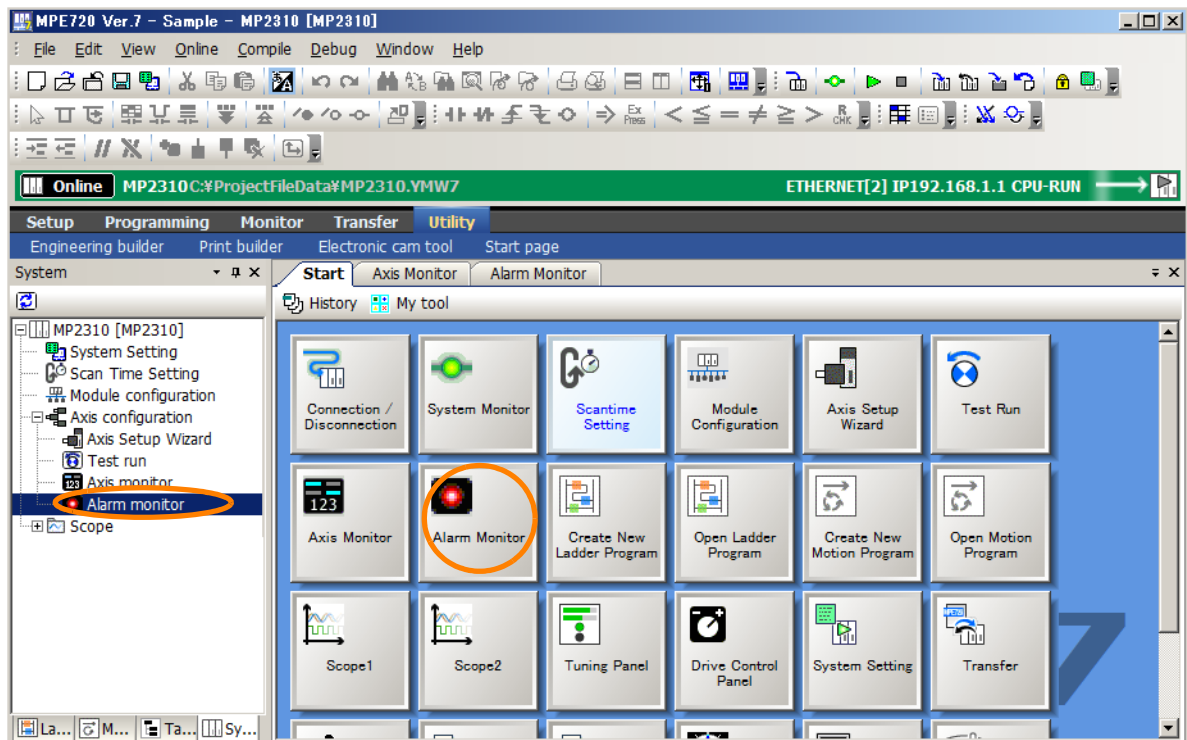

Names and Functions of the Alarm Monitor Tab Page Items

This tab page displays the warning and alarm status by circuit. The Alarm Monitor Tab Page can display up to eight axes in one horizontal row.

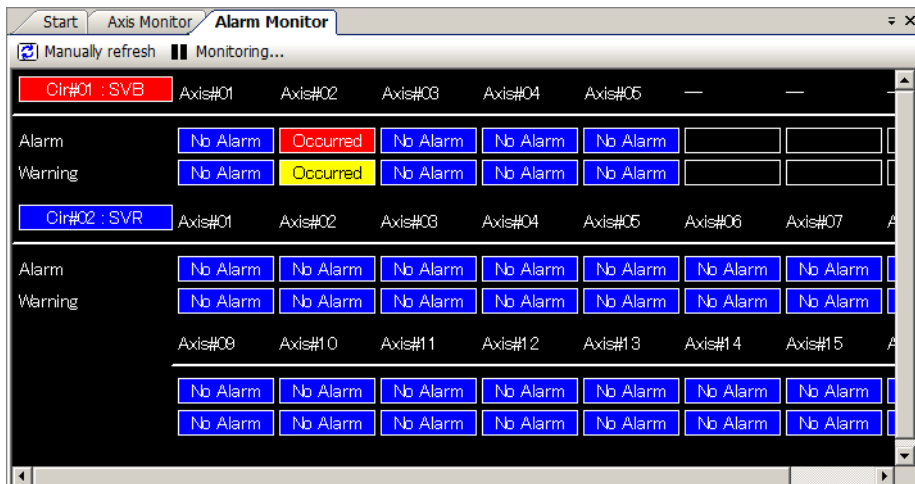

Note: In offline mode, all monitor data are displayed as -----.

■ Tool Bar

The toolbar contains icons to manually change the display contents, and to stop and start monitoring.

Icon	Name	Function
Manually refresh	Manually refresh	Use this button to update the alarm and warning information of the Alarm Monitor Tab Page. The Alarm Monitor Tab Page is not updated automatically.
Stop monitor Monitoring...	Stop monitor Start monitor	Stop monitor: Stops the monitor. Monitoring: The monitor is operating.

■ Circuit Number and Module Name

This box displays the circuit number and the name of the Motion Module.

Click the Circuit Number Box to display or hide the monitor data for that circuits. This allows you to display only the required axis data.

• When a Circuit Is Displayed

The alarm and warning data for that circuit will be displayed.

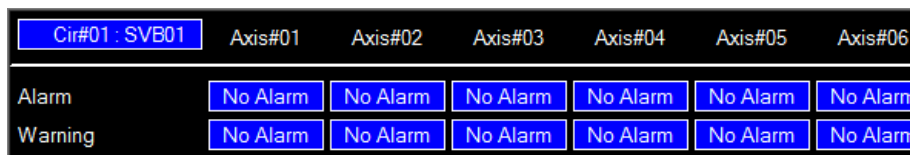

• When a Circuit Is Hidden

The alarm and warning data for that circuit will be hidden.



■ Status

If an alarm or a warning occurs, the alarm or warning status will be shown on the Alarm Monitor Tab Page in the following way:

Icon	Name	Function
No Alarm	No Alarm	No alarm or warning has occurred.
Occurred	Occurred	An alarm has occurred.
Occurred	Occurred	A warning has occurred.

Displaying Alarms and Warnings

If an alarm or a warning occurs, double-click the axis where the alarm or warning occurred to display the Alarm/Warning Dialog Box.

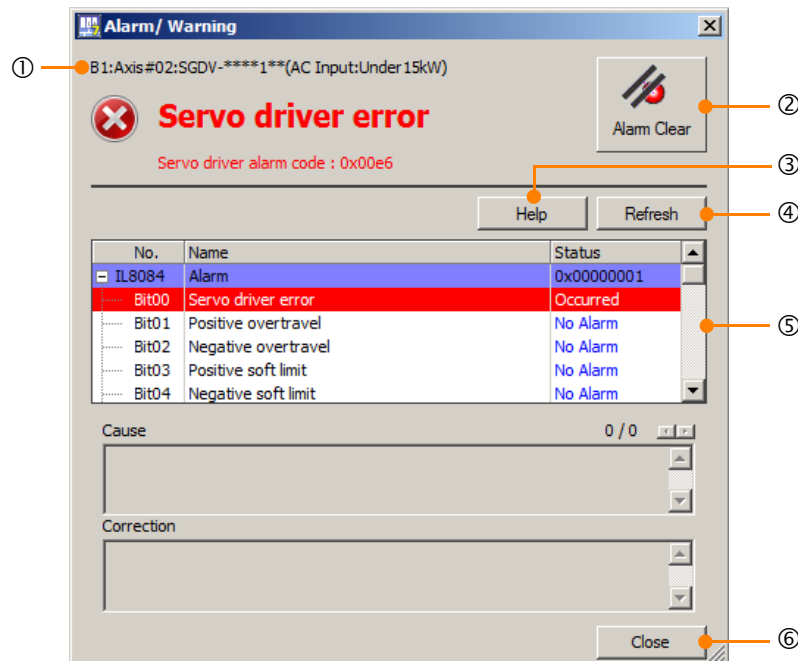

No.	Item	Function
①	Axis name	This row displays the name of the axis. The display takes the following format: Assigned axis number : Comment : Type.
②	Alarm Clear	This button clears the alarm.
③	Help	This button displays the manual related to the alarm that occurred: <i>MP2000 Series Troubleshooting Manual</i> (Manual No.: SIEP C880700 40).
④	Refresh	This button updates the contents of the Alarm/Warning Dialog Box.
⑤	Alarms/warnings display	Displays the parameter name, the bit number, and the status. This area shows the alarm and warning information bit by bit for each Motion Module.
⑥	Close	This button closes the Alarm/Warning Dialog Box.

Troubleshooting Alarms and Warnings

When an alarm occurs, the status will change to **Occurred**. When a warning occurs, the status will change to **Occurred**.

Click the status indicator to display the Alarm/Warning Dialog Box to see details on the alarm or warning.

This section uses a SERVOPACK Communications Error as an example to describe what to do when an alarm or warning occurs.

1. Click the status indicator in the Alarm Monitor.
The Alarm/Warning Dialog Box will be displayed.
2. Select the name of the alarm or warning where the status indicator shows **Occurred**.
The cause and corrective action will be displayed.

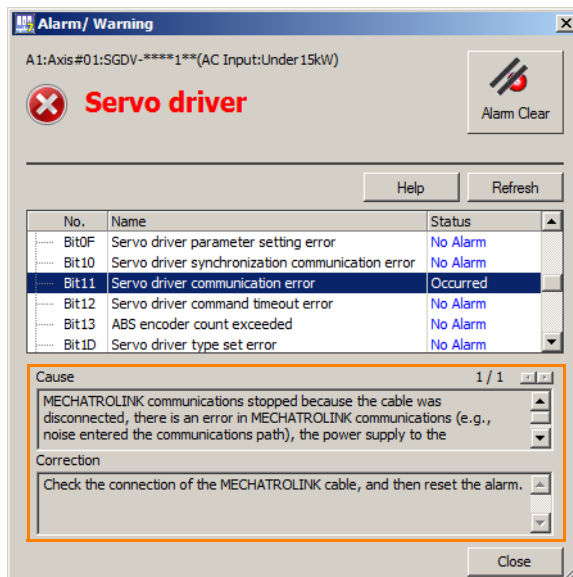

The *MP2000 Series Troubleshooting Manual* (Manual No.: SIEP C880700 40) will be opened and the information on the selected alarm or warning will be displayed.

Information If both an alarm and a warning occurred, the manual related to the alarm will be displayed.

3. Take corrective action by referring to the instructions listed in the Correction box.
4. Click the **Alarm Clear** Button.

If there are no other alarms or warnings, the status indicator will change to **No Alarm**.
If there are other alarms or warnings, repeat the procedure from step 1.

5.3.3 Introduction to Tracing

The MPE720 has the following three trace functions.

Function Name	Description
Real-Time Trace	You can monitor specified registers on a graph in real time.
Trace Manager*	You can have the Machine Controller collect data for specified registers during a specified time period, and perform operations on that data and plot it on a graph. This allows you to analyze register data that is acquired during specific time periods to debug ladder programs.
XY Trace	This tracing function acquires the position data of the X axis and Y axis every scan, and displays the data in a 2-dimensional graph.

With any of these three functions, you can export the trace data to CSV files. Use tracing to check operation and to debug the ladder programs and motion programs.

* The Trace Manager cannot be used for some register types, data types, and trace buffer types for tracing. Refer to the following table for details. Use a Real-Time Trace when the Trace Manager cannot be used.

- Register Types

Type	Name	Applicable Range	Support	
			Trace Manager	Real-Time Trace
S	System registers (S registers)	SW00000 to SW08191	Applicable	Applicable
		SW08192 to SW65534	Not applicable	Applicable
M	Data registers (M registers)	MW00000 to MW65534	Applicable	Applicable
		MW65535 to MW1048575	Not applicable	Applicable
G	G registers	GW0000000 to GW2097151	Not applicable	Applicable
I	Input registers (I registers)	IW00000 to IW0FFFF	Applicable	Applicable
		IW10000 to IW27FFF	Not applicable	Applicable
O	Output registers (O registers)	OW00000 to OW0FFFF	Applicable	Applicable
		OW10000 to OW27FFF	Not applicable	Applicable
D	D registers	DW00000 to DW16383	Applicable	Applicable

- Data Types

Symbol	Data Type	Support	
		Trace Manager	Real-Time Trace
B	Bit	Applicable	Applicable
W	Integer	Applicable	Applicable
L	Double-length integer	Applicable	Applicable
Q	Quadruple-length integer	Not applicable	Applicable
F	Real number	Applicable	Applicable
D	Double-length real number	Not applicable	Applicable
A	Address	Not applicable	Not applicable

- Trace Buffer Size

Maximum Applicable Trace Buffer Size		
Trace Manager	Real-Time Trace	
32 kwords	CPU-201, CPU-201 (SUB), CPU-202, CPU-202 (SUB), CPU-301 (32 axes)	1024 kwords
	CPU-301 (16 axes)	256 kwords

Selecting the Trace Type

The following describes how to select the trace type.

1. Display the Trace Type Dialog Box by one of the following methods.
 - Double-click **Scope 1**, **Scope 2**, **Scope 3**, or **Scope 4** in the System Pane of MPE720 version 7.
 - Click **Monitor – Scope** in the Launcher.
 - Click the **Scope 1**, **Scope 2**, **Scope 3**, or **Scope 4** Button that was registered in the My Tool Tab Page.

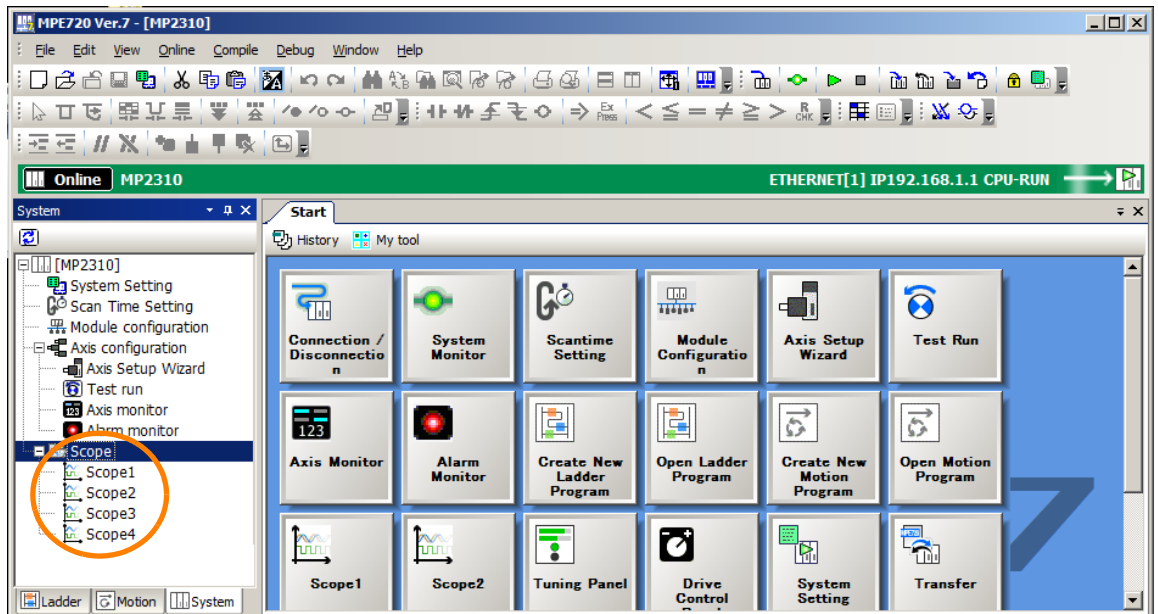

2. Select the desired trace type, and click the **Open** button.

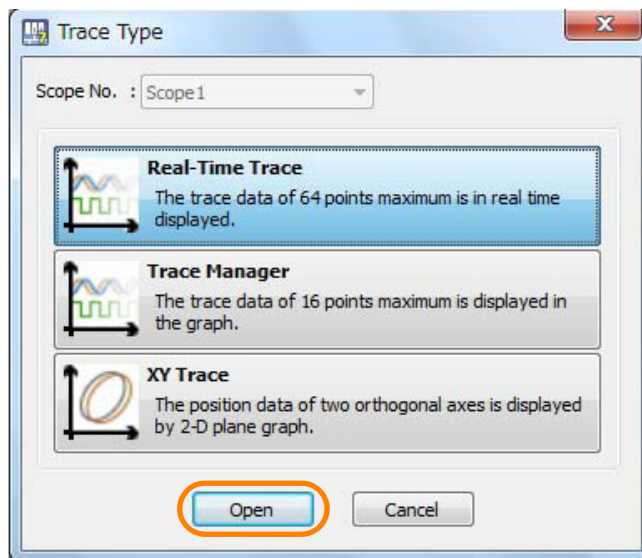

Realtime Tracing

Realtime tracing gets the register data from the Machine Controller and displays it in a graph. The results can be used to analyze the data movements and the timing scan by scan. There are various register data that you can get from the Machine Controller, including speed and torque data, and bit information.

Information MPE720 version 7 supports data tracing as a monitoring function. Data tracing get the I/O data of the Machine Controller when it is online, and calculates and draws a graph. You can use data tracing to monitor the operating status of the program and for debugging.

◆ Names and Functions of the Real-time Trace Tab Page Items



Graph Toolbar

page 5-40

The Graph Toolbar contains buttons to analyze the trace data.

Trace Execution Toolbar

page 5-41

This toolbar contains the **Trace Data Setting**, the **Sampling & Trigger Setting**, and the **Start Trace** Buttons to perform these operations in this order.

Trend Graph

page 5-46

This graph displays the trace data. You can use the Graph Toolbar, the sliders, and the cursors to analyze the trace data in realtime.

Trace List

page 5-50

The **Trace List** Area displays the trace data, and the file and history data.

■ Graph Toolbar

The following table gives details on the icons.

Icon	Function
	Click the Select Icon, and then double-click the target area to enlarge the display.
	Click the Scroll Icon to move the target area. Double-click the target area to enlarge the display.
	Click the Zoom In Icon, and then drag or double-click the target area to enlarge the display.
	Click the Reset Icon to return to the original display of the graph.
	Click the Split Graph Display Icon to display the graphs separately.
	Click the Cursor A Icon to display cursor A, and then move it on the graph to display the values.
	Click the Cursor B Icon to display cursor B, and then move it on the graph to display the values.
	Click the Cursor C Icon to display cursor C, and then move it on the graph to display the values.
	Click the Cursor D Icon to display cursor D, and then move it on the graph to display the values.
	Click the Cursor AB Link Icon to lock the horizontal distance between cursors A and B.
	Click the Cursor CD Link Icon to lock the vertical distance between cursors C and D.
	Click the List Icon to display the Trace List.
	Click the Copy Graph Icon to place a screen capture of the graph on the clipboard.

■ Trace Execution Toolbar

• Trace Data Settings

Setting the Registers to Trace



Click the **Trace Data Setting** Button to display the following dialog box:

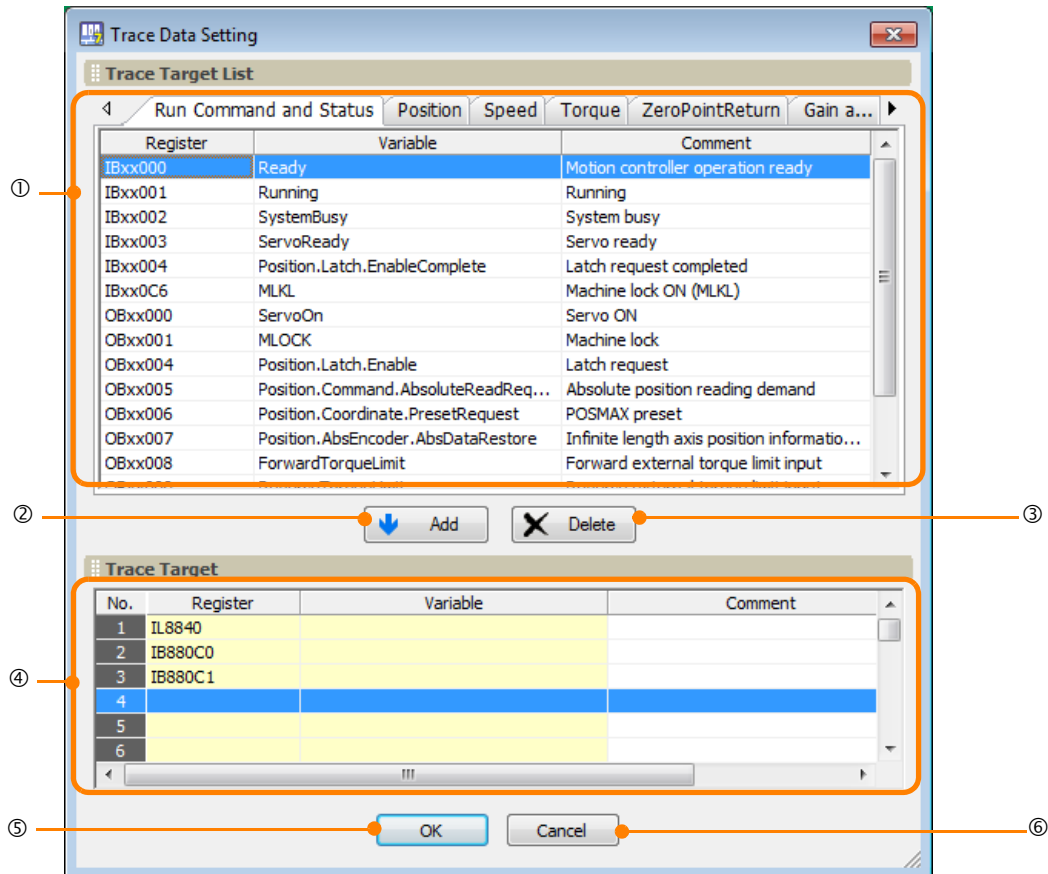

No.	Item	Description
①	Trace Target List	Displays a list of the registers that will be traced. Right-click in the Trace Target List to display the pop-up menu to select or deselect registers. Add to Trace adds the selected register to the Trace Target List. Clear deselects multiple registers that were selected by using the Shift or the Ctrl Keys. Select All selects all registers shown on the tab page.
②	Add	Use this button to add registers to the Trace Target List.
③	Delete	Use this button to delete the selected registers from the Trace Target List.
④	Trace Target	Displays the trace target registers. You can select the registers from the Trace Target List, or you can also enter the registers directly. Right-click in the Trace Target List to display the pop-up menu to edit the Trace Target List. Insert the Line inserts a blank row. Delete the Line deletes a row. If a trace target setting was added, then it will be deleted.
⑤	OK	The OK Button sets the Trace Target, and enables the Sampling & Trigger Setting Button.
⑥	Cancel	The Cancel Button returns you to the Real-Time Trace Dialog Box without setting the trace target.

• Sampling and Trigger Settings



This dialog box is used to set the trace name, the sampling settings, and the trigger setting parameters.

Click the **Sampling & Trigger Setting** Button to display the following dialog box:

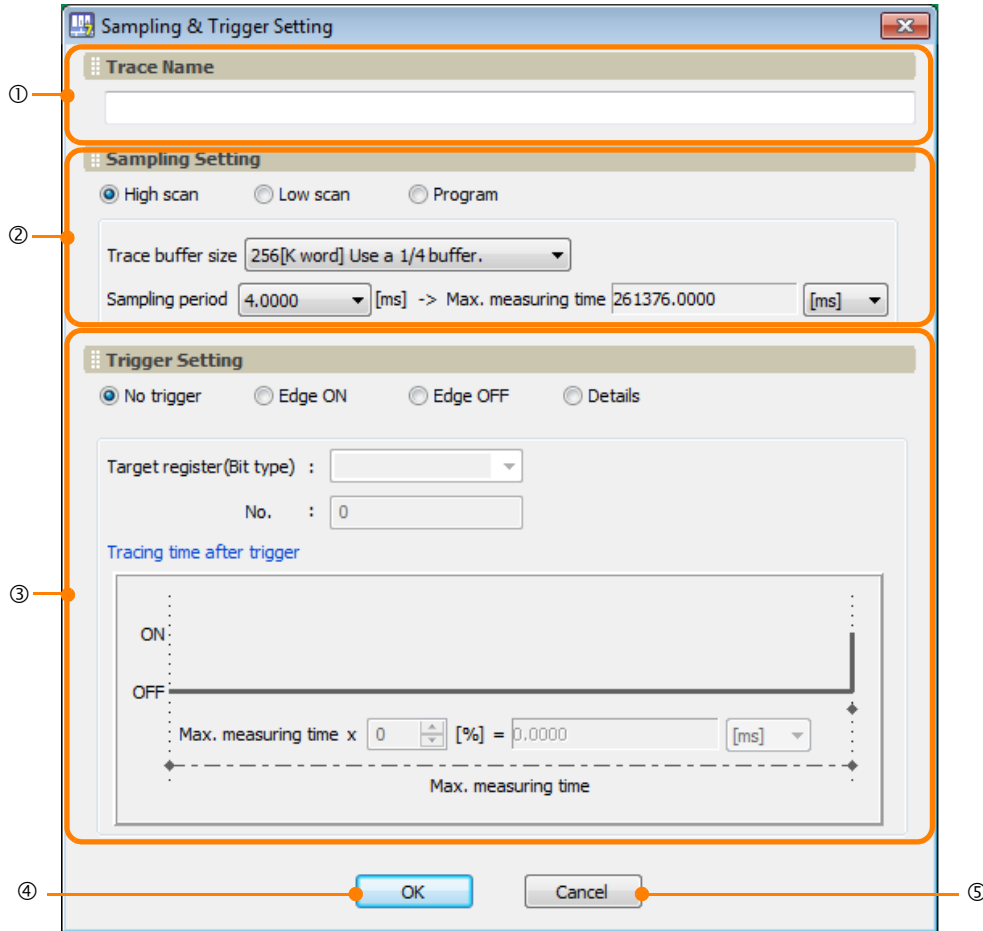

No.	Item	Description
①	Trace Name	Use this box to specify a name or comment for the trace. You can use up to 32 characters.
②	Sampling Setting	Use these options to set the data sampling conditions. The recommended maximum measurement time will be displayed.
③	Trigger Setting	These settings specify the method for starting the trace data sampling. Refer to the following section for details.  <i>Trigger Setting Details (page 5-42)</i>
④	OK	Click the OK Button to set the sampling and trigger settings, and to enable the Start Trace Button.
⑤	Cancel	Click the Cancel Button to return to the Real-Time Trace Dialog Box without setting the sampling and trigger settings.

• Trigger Setting Details

These settings specify the conditions for starting the trace. There are four methods to start the data sampling.

- No Trigger
Use this option to start and stop the sampling manually.

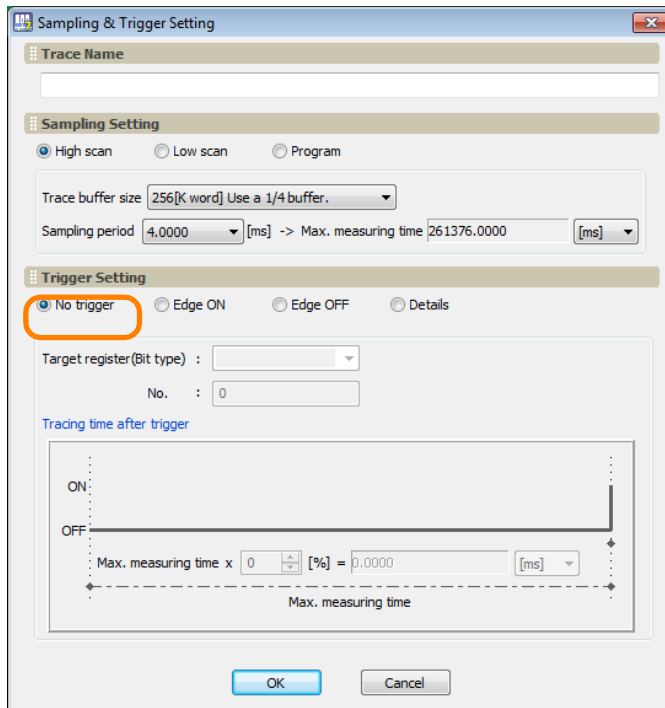

- Edge ON or Edge OFF
Use these options to sample the data before and after a specified bit changes from OFF to ON or from ON to OFF.

Edge ON:

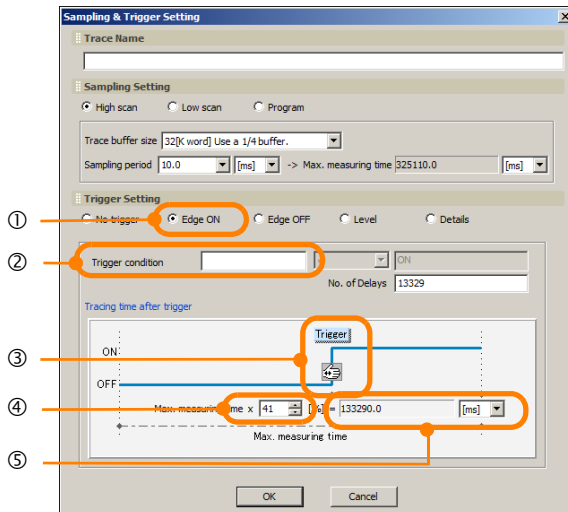

Edge OFF:

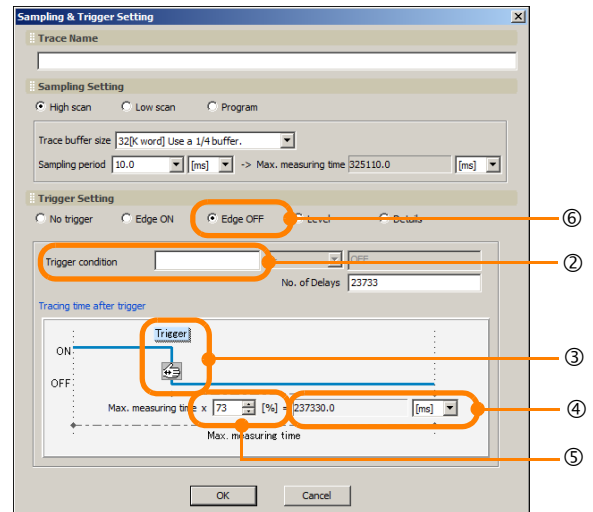

No.	Item	Description
①	Edge ON	Use these options to sample the data before and after a specified bit changes from OFF to ON.
②	Edge OFF	Use these options to sample the data before and after a specified bit changes from ON to OFF.
③	Trigger condition: Target register	Enter the target register to be used as a trigger condition. Only registers whose data type is bit (B) are targeted. Integer (W), double-length integer (L), quadruple-length integer (Q), real number (F), double-precision real number (D), and address (A) are not targeted.
④	No. of Delays	Set the number of samplings to execute after the terminate trigger condition has been met and before the trace is stopped.
⑤		Drag this icon to set the trigger position.
⑥	%	Select the numeric value to set for the trigger position.
⑦	ms	The maximum measurement time after the trigger is displayed in this box.

- [Level]
 Preceding and subsequent data when any register matches the trigger condition is acquired.

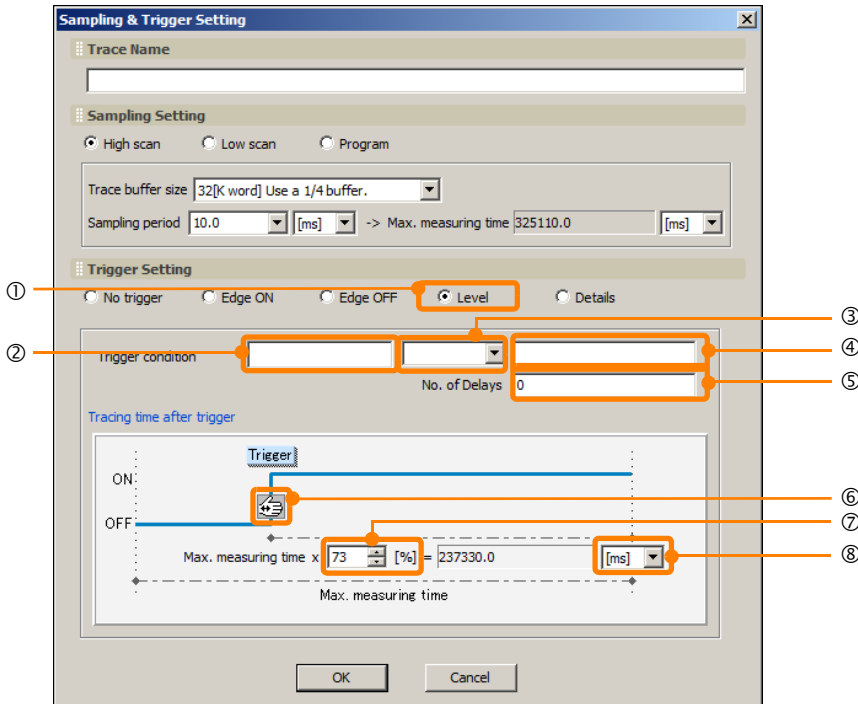

No.	Item	Description																										
①	Level	Preceding and subsequent data when any register matches the trigger condition is acquired.																										
②	Trigger condition: Target register	Enter the target register to be used as a trigger condition. Only registers whose data type is integer (W), double-length integer (L), quadruple-length integer (Q), real number (F), and double-precision real number (D) are targeted. Registers whose data type is bit (B) and address (A) are not targeted.																										
③	Trigger condition: Establishment of conditions	Select from the following operators.																										
		<table border="1"> <thead> <tr> <th>Operator</th> <th>Trigger</th> </tr> </thead> <tbody> <tr> <td>></td> <td>A trigger occurs when the register value is greater than the comparison value.</td> </tr> <tr> <td><</td> <td>A trigger occurs when the register value is less than the comparison value.</td> </tr> <tr> <td>=</td> <td>A trigger occurs when the register value is equal to the comparison value.</td> </tr> <tr> <td><></td> <td>A trigger occurs when the register value is not equal to the comparison value.</td> </tr> <tr> <td>>=</td> <td>A trigger occurs when the register value is greater than or equal to the comparison value.</td> </tr> <tr> <td><=</td> <td>A trigger occurs when the register value is less than or equal to the comparison value.</td> </tr> <tr> <td>> (differential)</td> <td>A trigger occurs when the register value changes from a value less than the comparison value to a value greater than the comparison value.</td> </tr> <tr> <td>< (differential)</td> <td>A trigger occurs when the register value changes from a value greater than the comparison value to a value less than the comparison value.</td> </tr> <tr> <td>= (differential)</td> <td>A trigger occurs when the register value changes from a value not equal to the comparison value to a value equal to the comparison value.</td> </tr> <tr> <td><> (differential)</td> <td>A trigger occurs when the register value changes from a value equal to the comparison value to a value not equal to the comparison value.</td> </tr> <tr> <td>>= (differential)</td> <td>A trigger occurs when the register value changes from a value less than the comparison value to a value the same as or greater than the comparison value.</td> </tr> <tr> <td><= (differential)</td> <td>A trigger occurs when the register value changes from a value greater than the comparison value to a value less than or equal to the comparison value.</td> </tr> </tbody> </table>	Operator	Trigger	>	A trigger occurs when the register value is greater than the comparison value.	<	A trigger occurs when the register value is less than the comparison value.	=	A trigger occurs when the register value is equal to the comparison value.	<>	A trigger occurs when the register value is not equal to the comparison value.	>=	A trigger occurs when the register value is greater than or equal to the comparison value.	<=	A trigger occurs when the register value is less than or equal to the comparison value.	> (differential)	A trigger occurs when the register value changes from a value less than the comparison value to a value greater than the comparison value.	< (differential)	A trigger occurs when the register value changes from a value greater than the comparison value to a value less than the comparison value.	= (differential)	A trigger occurs when the register value changes from a value not equal to the comparison value to a value equal to the comparison value.	<> (differential)	A trigger occurs when the register value changes from a value equal to the comparison value to a value not equal to the comparison value.	>= (differential)	A trigger occurs when the register value changes from a value less than the comparison value to a value the same as or greater than the comparison value.	<= (differential)	A trigger occurs when the register value changes from a value greater than the comparison value to a value less than or equal to the comparison value.
		Operator	Trigger																									
		>	A trigger occurs when the register value is greater than the comparison value.																									
		<	A trigger occurs when the register value is less than the comparison value.																									
		=	A trigger occurs when the register value is equal to the comparison value.																									
		<>	A trigger occurs when the register value is not equal to the comparison value.																									
		>=	A trigger occurs when the register value is greater than or equal to the comparison value.																									
		<=	A trigger occurs when the register value is less than or equal to the comparison value.																									
		> (differential)	A trigger occurs when the register value changes from a value less than the comparison value to a value greater than the comparison value.																									
< (differential)	A trigger occurs when the register value changes from a value greater than the comparison value to a value less than the comparison value.																											
= (differential)	A trigger occurs when the register value changes from a value not equal to the comparison value to a value equal to the comparison value.																											
<> (differential)	A trigger occurs when the register value changes from a value equal to the comparison value to a value not equal to the comparison value.																											
>= (differential)	A trigger occurs when the register value changes from a value less than the comparison value to a value the same as or greater than the comparison value.																											
<= (differential)	A trigger occurs when the register value changes from a value greater than the comparison value to a value less than or equal to the comparison value.																											
④	Trigger condition: Value	Enter the comparison value.																										

Continued on next page.

Continued from previous page.

No.	Item	Description
⑤	No. of Delays	Set the number of samplings to execute after the terminate trigger condition has been met and before the trace is stopped.
⑥		Select the value, and set the trigger position.
⑦	[%]	Move by dragging to set the trigger position.
⑧	Max. measuring time	Select the display unit for the measuring time. The maximum measuring time of the trace after the trigger is displayed by the display unit set here.

- Details
Use this Option to specify a register for triggering the trace.

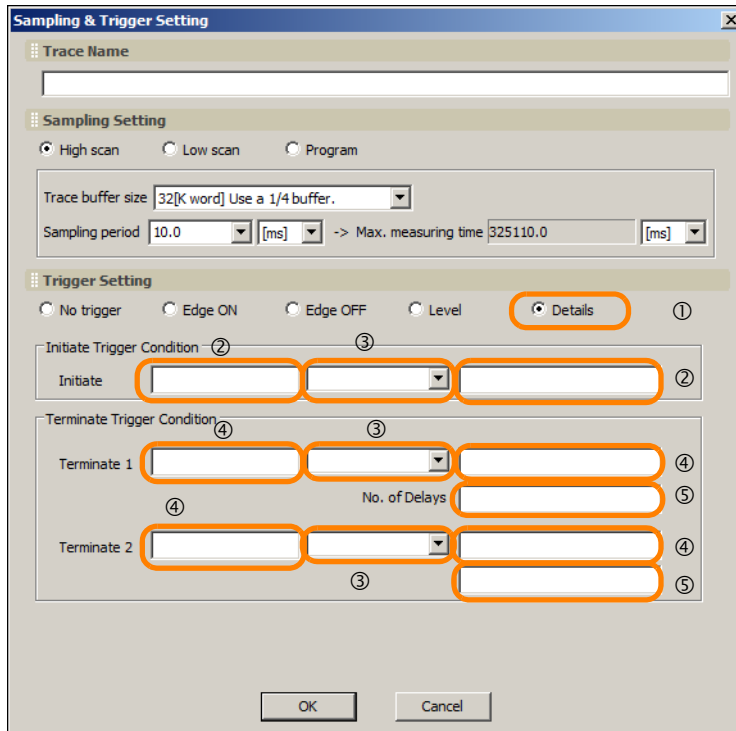

No.	Item	Description												
①	Details	Use this option to specify the register (Bit, Word, Float, or Long) to use to trigger the trace. You can freely create the desired combination of conditions to start and stop the trace.												
②	Initiate	Enter any register and value to start the trace. If the initiate trigger is not specified, tracing will start at the same time as the sampling.												
③	Condition	Select from the following operators:												
		<table border="1"> <thead> <tr> <th>Operator</th> <th>Trigger</th> </tr> </thead> <tbody> <tr> <td>></td> <td>A trigger occurs when the register value is greater than the comparison value.</td> </tr> <tr> <td><</td> <td>A trigger occurs when the register value is less than the comparison value.</td> </tr> <tr> <td>=</td> <td>A trigger occurs when the register value is equal to the comparison value.</td> </tr> <tr> <td><></td> <td>A trigger occurs when the register value is not equal to the comparison value.</td> </tr> <tr> <td>>=</td> <td>A trigger occurs when the register value is greater than or equal to the comparison value.</td> </tr> <tr> <td><=</td> <td>A trigger occurs when the register value is less than or equal to the comparison value.</td> </tr> </tbody> </table>	Operator	Trigger	>	A trigger occurs when the register value is greater than the comparison value.	<	A trigger occurs when the register value is less than the comparison value.	=	A trigger occurs when the register value is equal to the comparison value.	<>	A trigger occurs when the register value is not equal to the comparison value.	>=	A trigger occurs when the register value is greater than or equal to the comparison value.
Operator	Trigger													
>	A trigger occurs when the register value is greater than the comparison value.													
<	A trigger occurs when the register value is less than the comparison value.													
=	A trigger occurs when the register value is equal to the comparison value.													
<>	A trigger occurs when the register value is not equal to the comparison value.													
>=	A trigger occurs when the register value is greater than or equal to the comparison value.													
<=	A trigger occurs when the register value is less than or equal to the comparison value.													
④	Terminate	Enter any register and value to start the trace. If a terminate trigger is not specified, tracing will continue until the sampling stops.												
⑤	No. of Delays	Set the number of samplings to execute after the terminate trigger condition has been met and before the trace is stopped.												

• Starting and Stopping Traces



Function	Description
Start Trace	Use this button to start the trace. The data that is sampled will be displayed in realtime. If the Program Option was selected in the Sampling & Trigger Setting Dialog Box, the trace cannot be started manually. You can use only the Read Again Button.
Real Time Display	Select the Real Time Display Check Box to display the trace data moving in realtime. If more than one Trace Tab Page is open, you can use a realtime display for only one of them.
Stop Trace	Use this button to stop the trace. When you press the Stop Button, all trace buffer data will be collected and displayed.

• Read Again

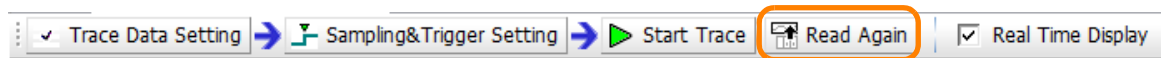

The **Read Again** Button re-reads the trace data from the Machine Controller.

■ Trend Graph

• Graph Unit

The unit of the parameter that was selected for the trace target will be displayed on the graph.

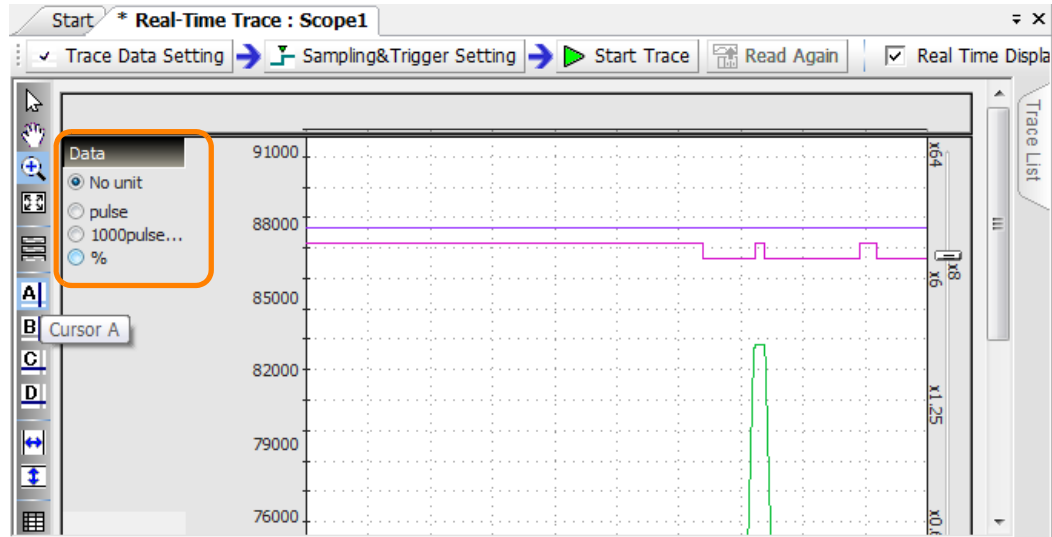

• Cursors

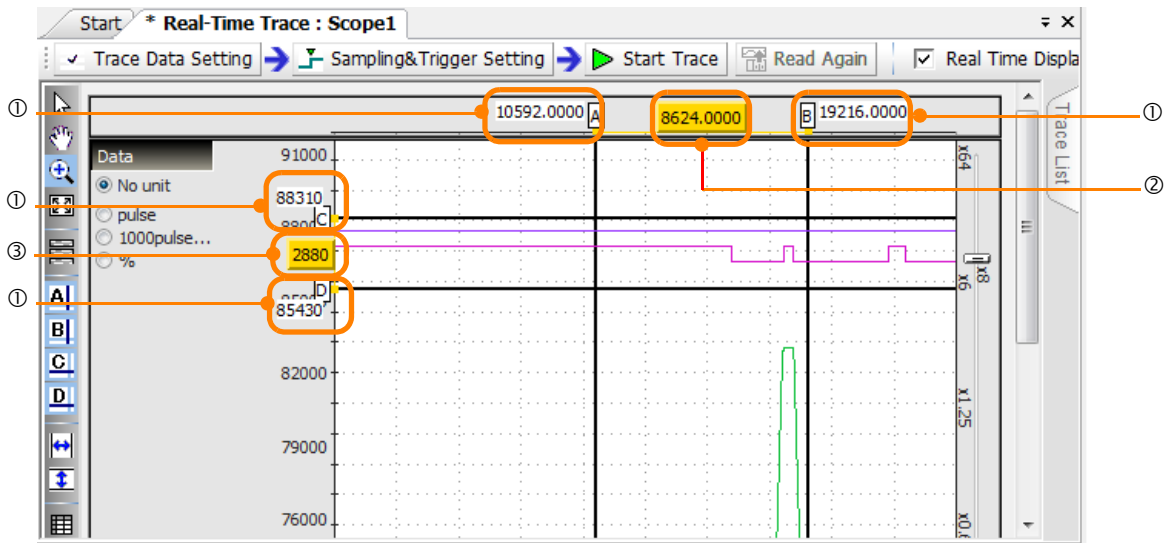

No.	Display	Function
①		These boxes display the values of the cursor positions.
②	-	This box displays the horizontal distance between the positions of cursor A and cursor B.
③	-	This box displays the vertical distance between the positions of cursor C and cursor D.

• Sliders

Drag a scale sliders up and down or to the left and right to zoom in and out of the graph.

The scales have the following ranges:

Vertical scale: $\times 0.085$ to $\times 64$

Horizontal scale: $\times 1$ to $\times 48.5$

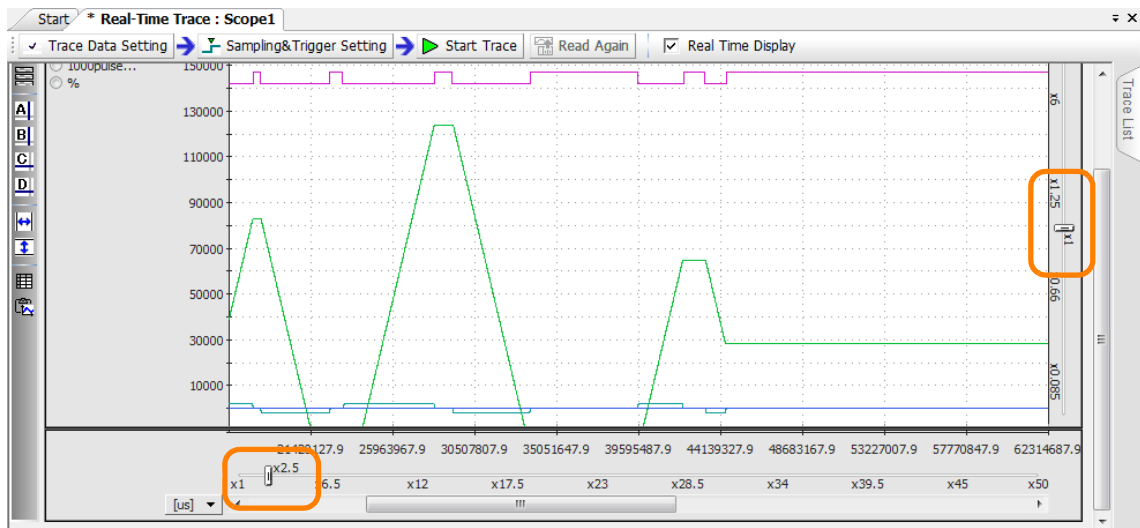

- Scrollbar

Slide the scrollbar to the left and right to display the graph.

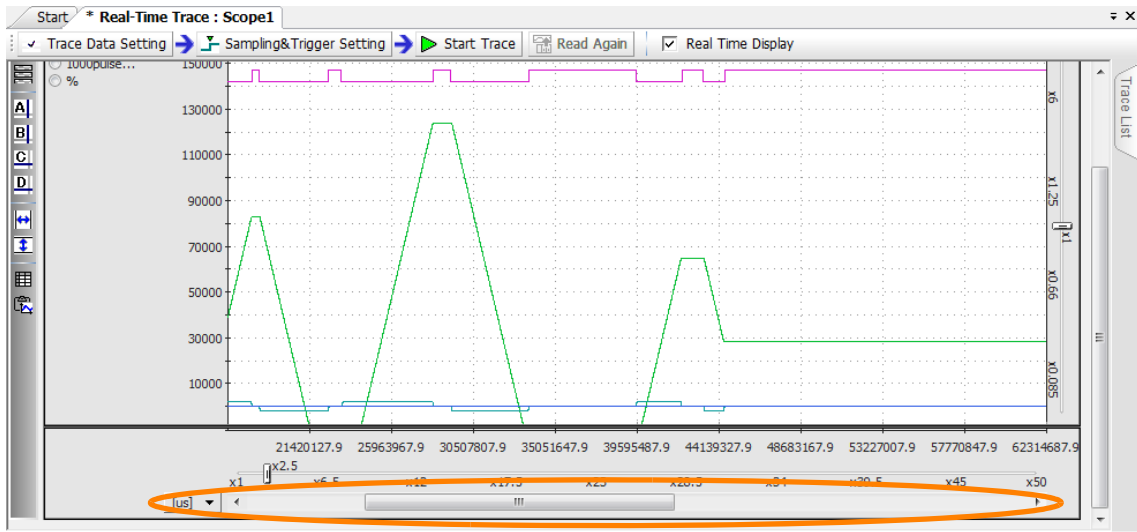

- Split Graph Displays

You can group the trace data by data type and assign a separate graph for each group, creating a split display.

The trace data consist of the group that is on the Trace Target List Tab Page, and the group of other registers.

You can switch between the split display and the combined display.

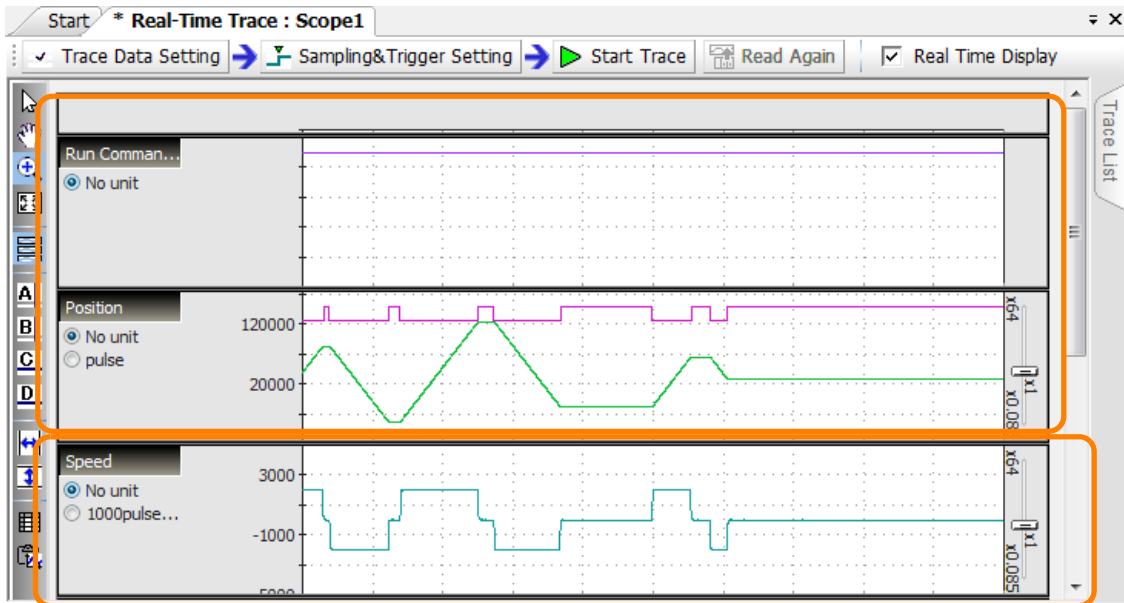

• Changing the Graph Unit

If the trace data has more than one unit, you can change the unit for the vertical axis of the graph.

When you do that, the scale of the vertical axis will change according to the axis information (unit and decimal digits), and the waveforms will be displayed accordingly.

Information

1. The available units depend on the axis information.
2. The axis unit can be changed regardless of the graph display method. It works for the split display as well as for the combined display. When you change the unit, the color of the trace lines that have a different unit will be dimmed.

No Unit:

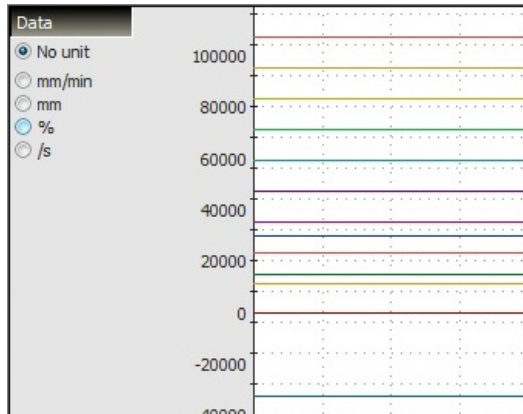

Millimeters (mm):

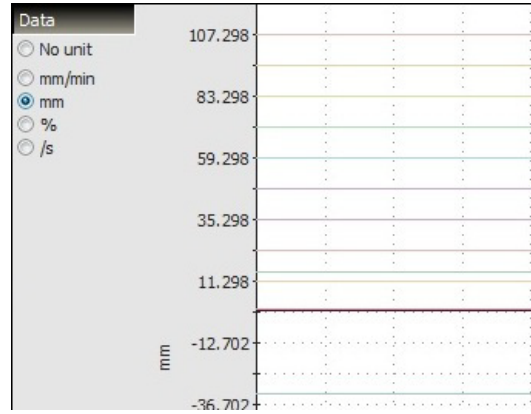

■ Trace List

The Trace List displays the traced data, the trace data that was read from external files, and a history of the trace data.

You can use this information to check the waveforms, the displayed graphs, and details on the traced data.

Use the check boxes to show or hide the waveforms on the graph display.

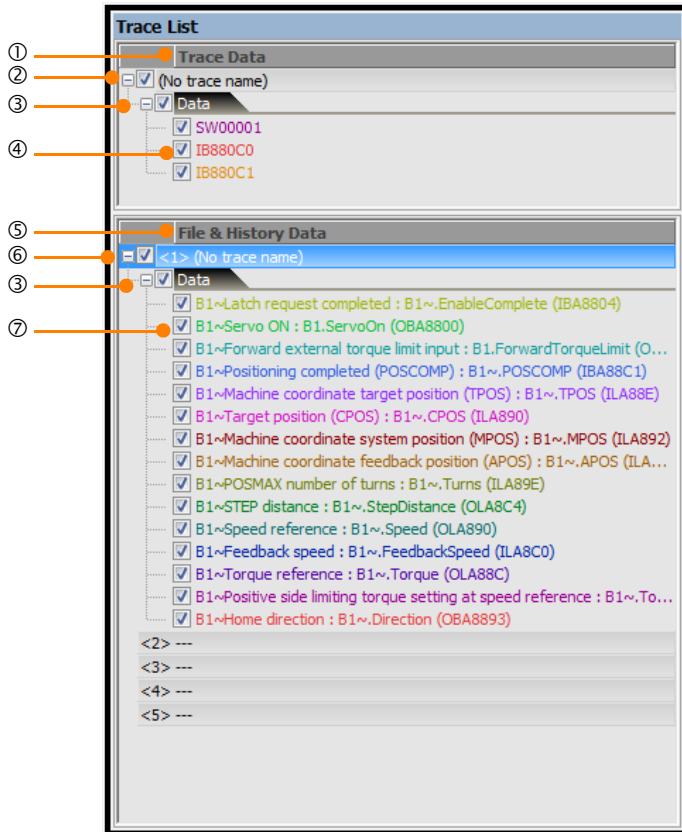

No.	Display	Function
①	Trace Data	Displays the trace data of the traced targets.
②	Trace name	Displays the name of the trace.
③	Trace group name	The trace data is displayed in groups, where one group consists of the data that was included in the Trace Target List Tab Page of the Trace Data Setting Dialog Box, and the other group consists of other data.
④	Registers	Displays the registers that were traced. The register names are displayed in the same color as their trace lines.
⑤	File & History Data	Displays a list of trace targets that were registered for tracing, and trace data that was read from external files.
⑥	Trace name	Displays the name of trace data that was registered for tracing, and trace data that was read from external files. You can save up to five backups of the file and history data.
⑦	Registers	Displays the names of trace data that was registered for tracing, and traced registers that were read from external files. The register names are displayed in the same color as their trace lines.

◆ Displaying Measurement Information

You can view the trace definition information of monitor data and history data that you set as sampling and trigger setting information.

This allows you to view and reuse the trace definitions from past measurements.

Select **Trace Data – Sampling & Trigger Setting Information** from the MPE720 version 7 menu bar to display the Sampling & Trigger Setting Information Dialog Box.

Alternatively, right-click **Trace Data** or **File & History Data** in the Trace List Pane, and select **Sampling & Trigger Setting Information** from the pop-up menu.

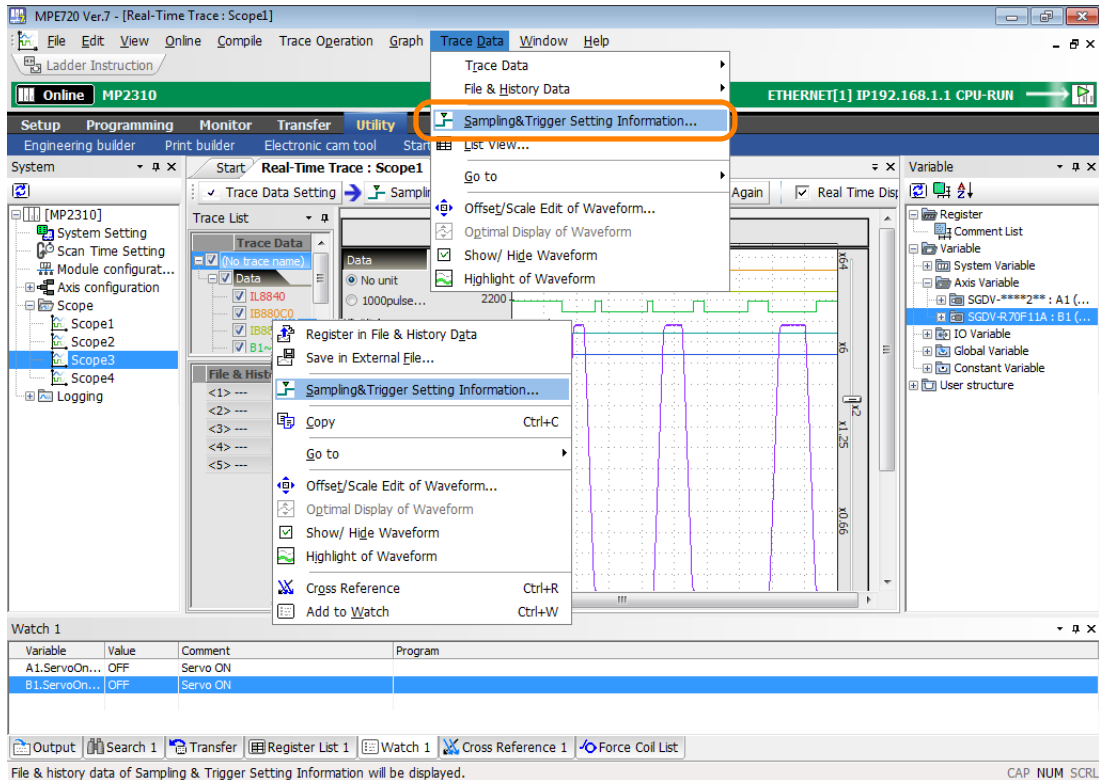

◆ Editing the Trace Data

You can enlarge or reduce the waveform of the trace data, or move its position. Changing the size or position helps you compare the waveform to other lines for analysis.

Information When the trace data is refreshed, the size and position will be reset.

Select **Trace Data – Offset/Scale Edit of Waveform** from MPE720 version 7 menu bar to display the Offset/Scale Edit of Waveform Dialog Box.

Alternatively, right-click **Trace Data** or **File & History Data** in the Trace List Pane, and select **Offset/Scale Edit of Waveform** from the pop-up menu.

Information If you display the pop-up menu by right-clicking on a group name, you can edit the waveforms of the entire group.

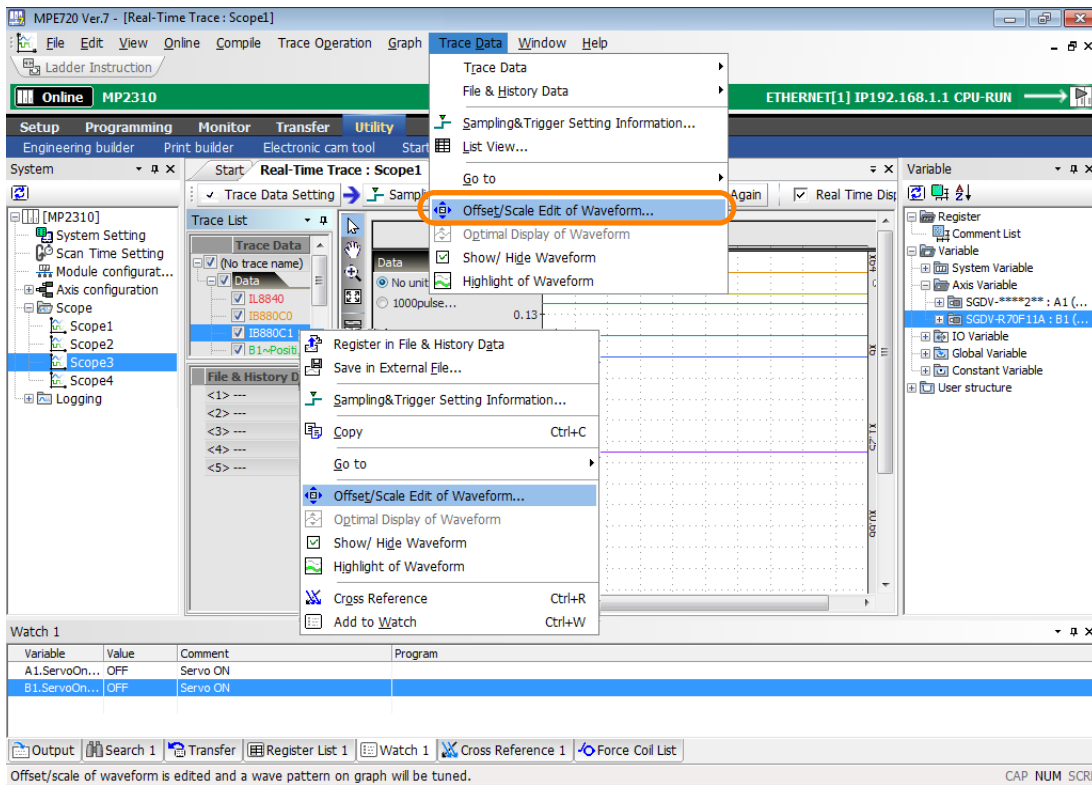

The Offset/Scale Edit of Waveform Dialog Box contains the following items:

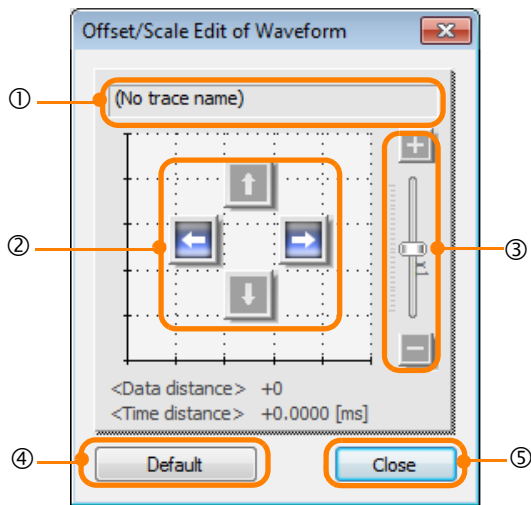

No.	Display	Function
①	Trace name	This box displays the name of the trace and the file.
②	Offset move buttons	Use these buttons to move the waveforms of the specified trace data.
③	Scale adjustment slider	Use this slider to increase/decrease the amplitude of waveforms of the specified trace data.
④	Default	Click this button to return the trace data to the default settings.
⑤	Close	Click this button to close the Offset/Scale Edit of Waveform Dialog Box.

◆ Analyzing the Trace Data

You can use the trace data editing and zooming features to analyze the trace data.

■ Analyzing the I/O Registers and the M Registers

This section describes how to analyze the differences between set values and actual values.

1. Display the trace data to analyze on the graph.
2. Select **Trace Data – File & History Data** from the menu bar. Alternatively, right-click **Trace Data** or **File & History Data** in the Trace List Pane, and select **Edit Trace Data** from the pop-up menu.
3. Use the arrow buttons to move to the location to use for comparison.
4. Click the Cursor A and Cursor B Icons or the Cursor C and Cursor D Icons on the Graph Toolbar to display the cursors, and align them on the registers to analyze.



5. The difference between the waveform of the set register values and the waveform of the actual output values of the register is analyzed.

■ Comparison to Data Sampled in the Past

This section describes how to compare trace data that was read from the Machine Controller to trace data that was sampled in the past.

1. If you read trace data from an external file into the **File & History Data** in the Trace List Pane, the trace data waveform will be displayed as shown in the following figure.

Note: If the trace data has already been loaded, then select the check box at the trace definition.

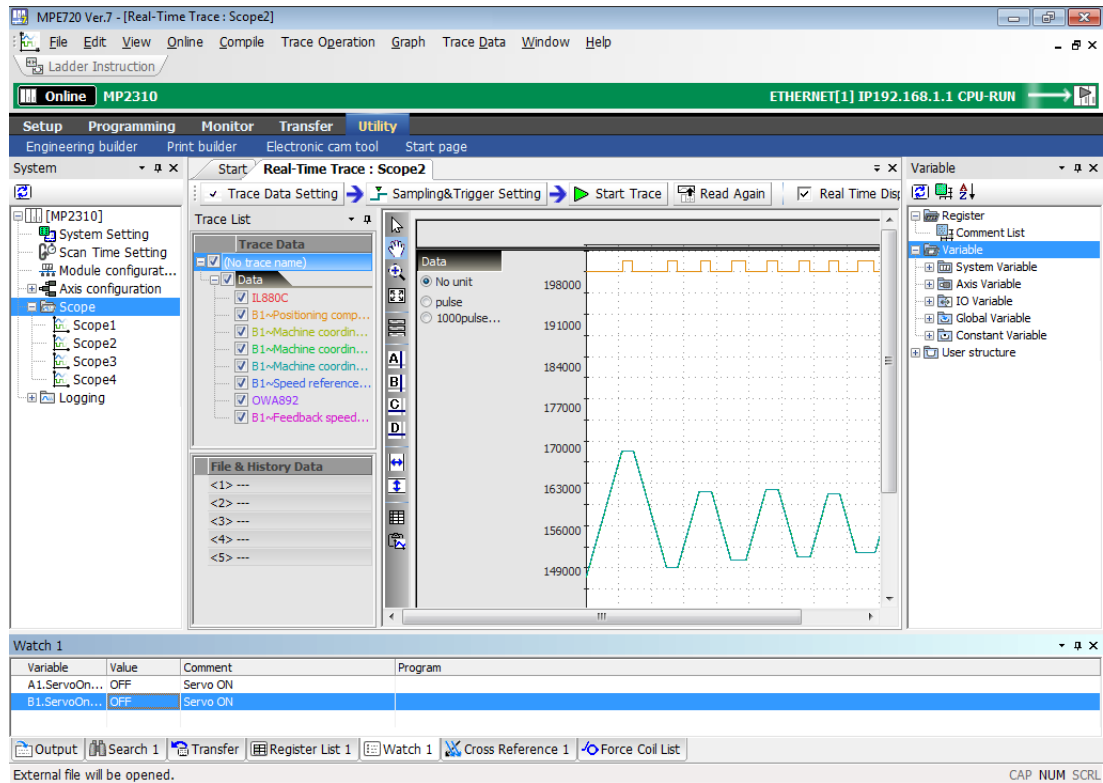

2. Select **Trace Data – Offset/Scale Edit of Waveform** from the menu bar. Alternatively, right-click **Trace Data** or **File & History Data** in the Trace List Pane, and select **Offset/Scale Edit of Waveform** from the pop-up menu.

The Offset/Scale Edit of Waveform Dialog Box will be displayed.

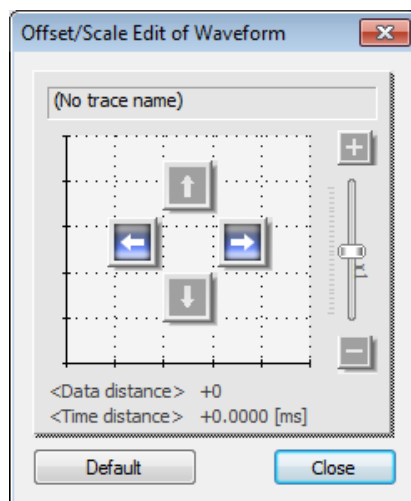

3. Use the arrow buttons to move the start position of the data to the desired location.
4. Use the editing functions, such as zoom in, zoom out, or the slider, to compare the data to the past trace data.

◆ Reading Trace Data

This section describes how to read saved trace data. Trace definition files (.dat) and CSV files (.csv) can be read.

Select **File – Open External File** from the menu bar. The Open Dialog Box will be displayed. Select the saved CSV file or trace definition file to open.

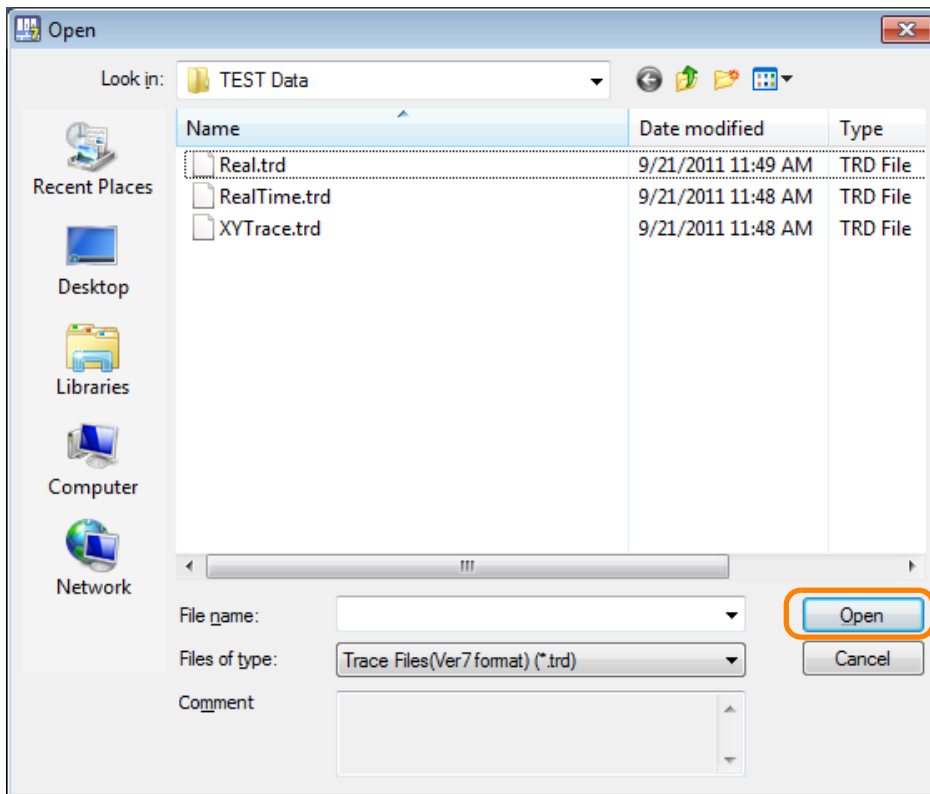
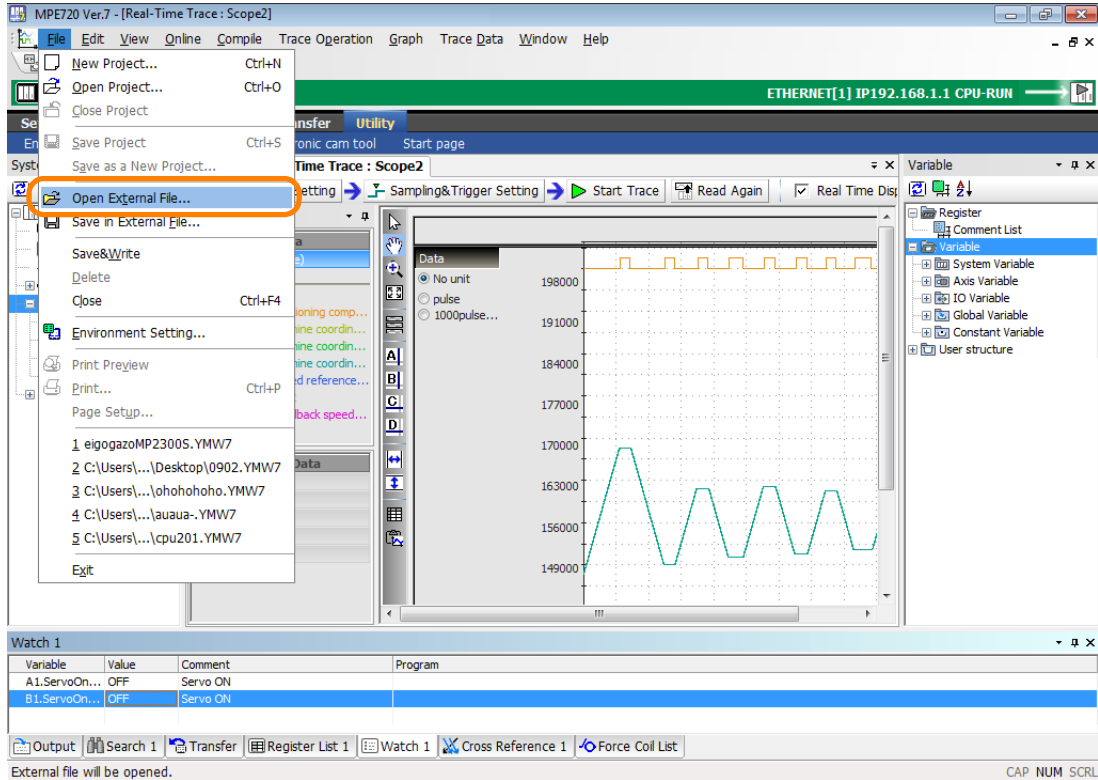

◆ Saving the Trace Data

This section describes how to save the trace data into a CSV file or a trace definition file.

Data can be analyzed if it is saved into a CSV or a trace definition file.

Select **File – Save in External File** from the menu bar. Select a CSV or a trace definition file, specify a name, and save it.

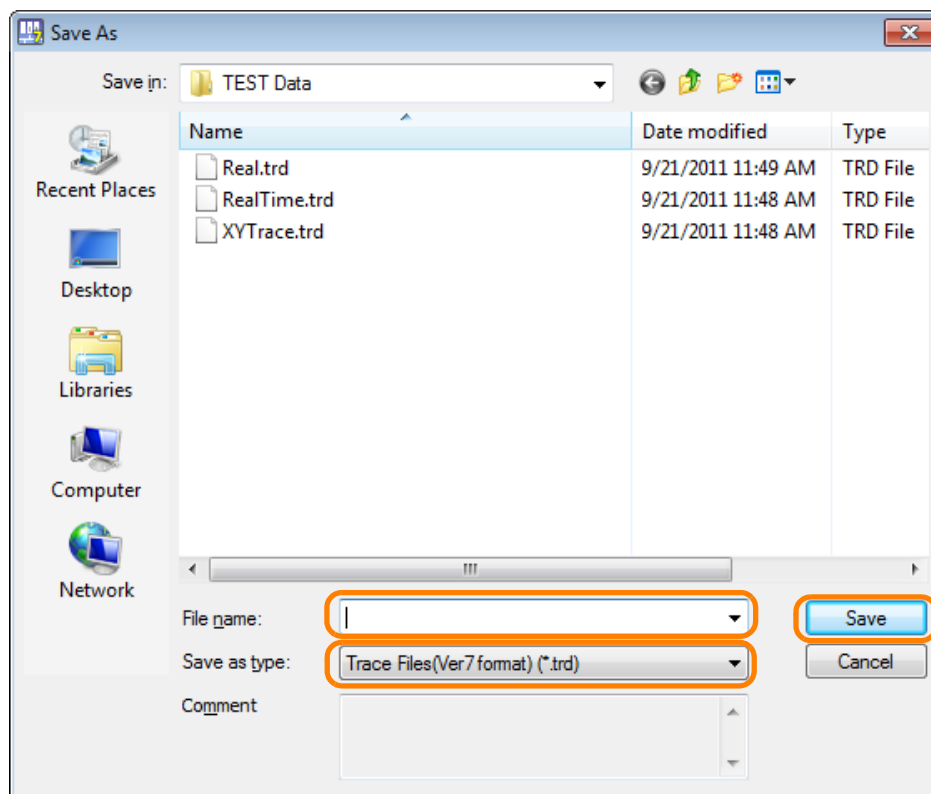
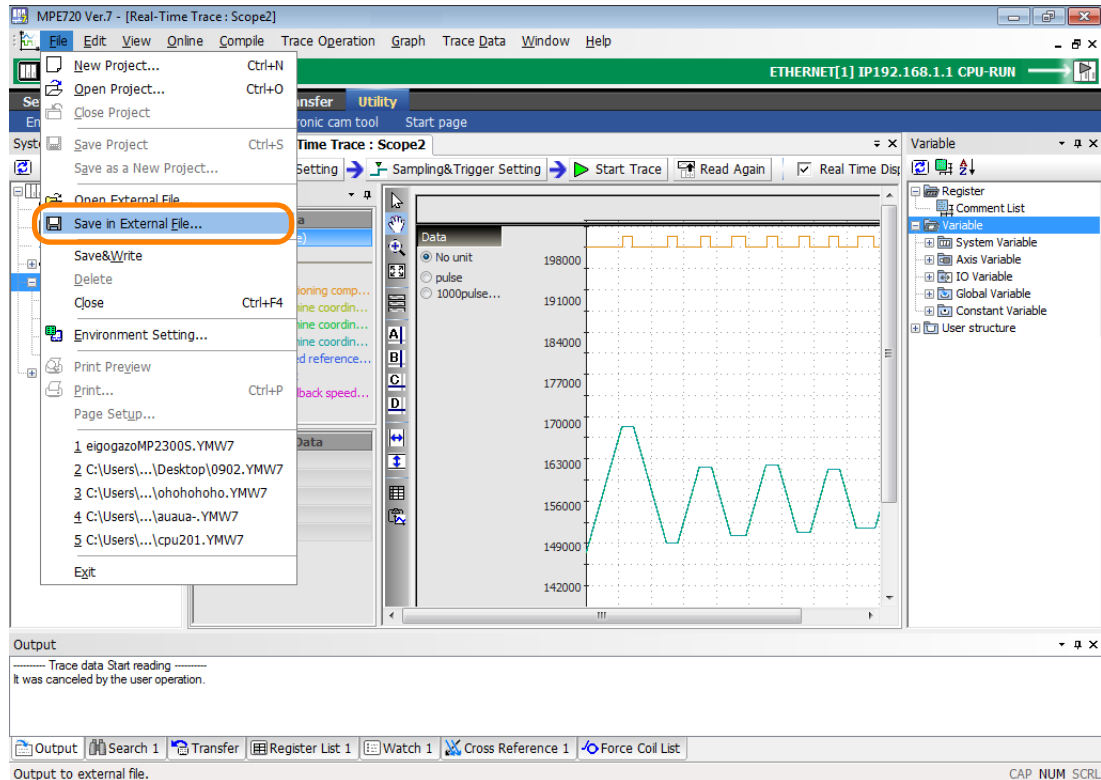

Information You can also display a list and copy from the trace list to an Excel file.

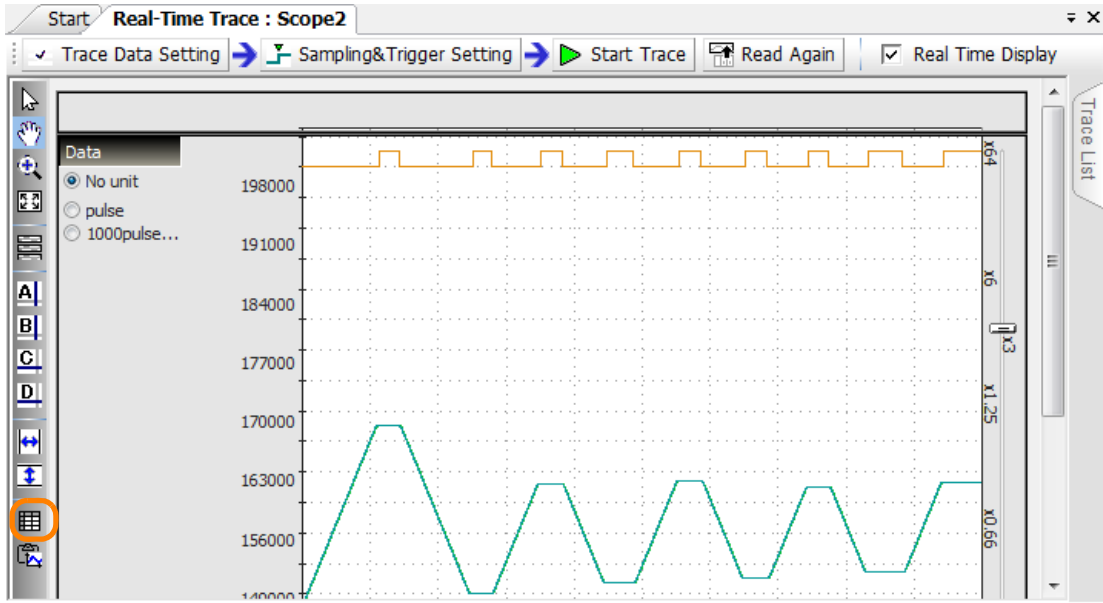

◆ List View

You can display the graph data in a list.

You can display the trace data and the history data in a list.

Select **Trace Data – List View** from the menu bar. When you select **List View**, the trace data that is displayed in the graph will be displayed as a list.

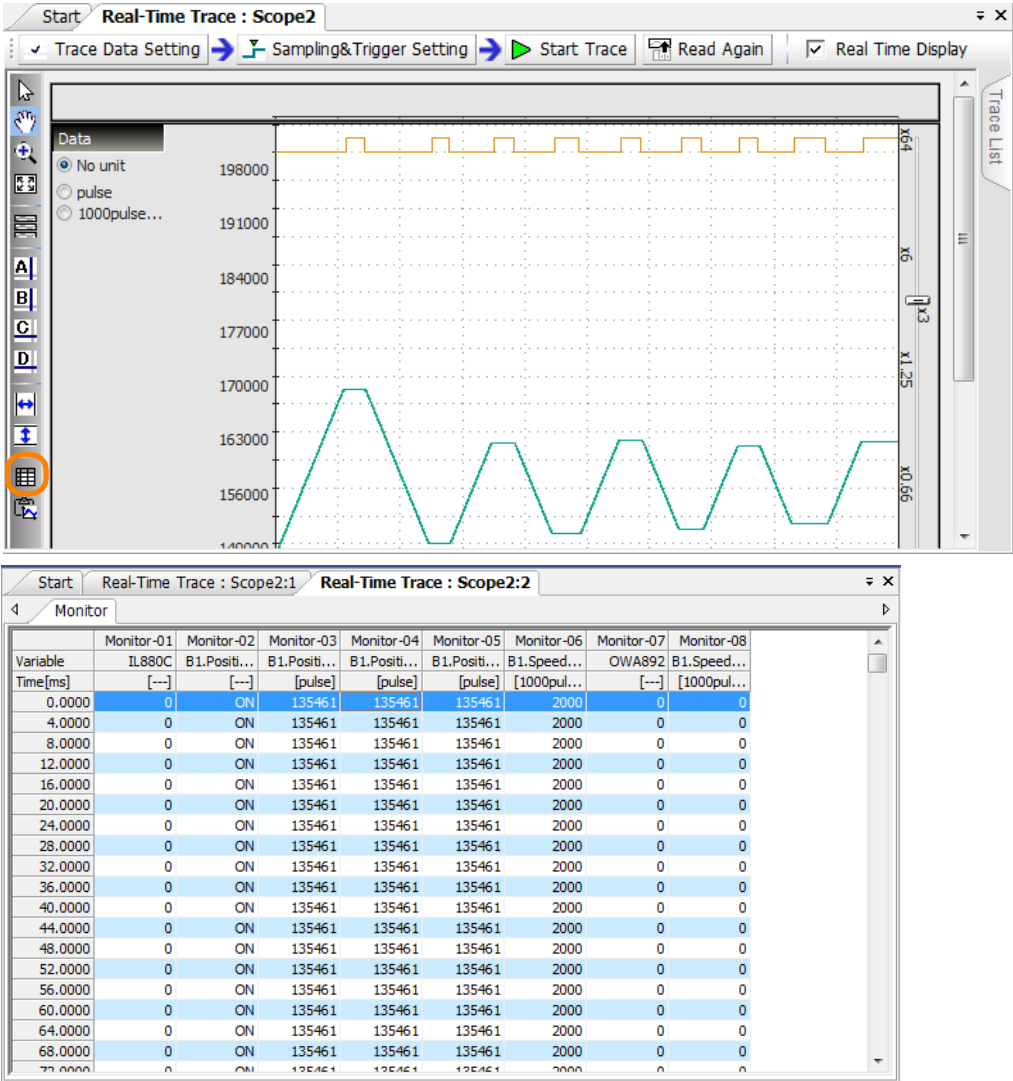

◆ Copying a Graph

You can place a screen capture of the graph on the clipboard.

Select **Graph – Copy Graph** from the menu bar. Alternatively, click the **Copy Graph** Icon on the Graph Toolbar. The screen capture of the graph will be placed on the clipboard.

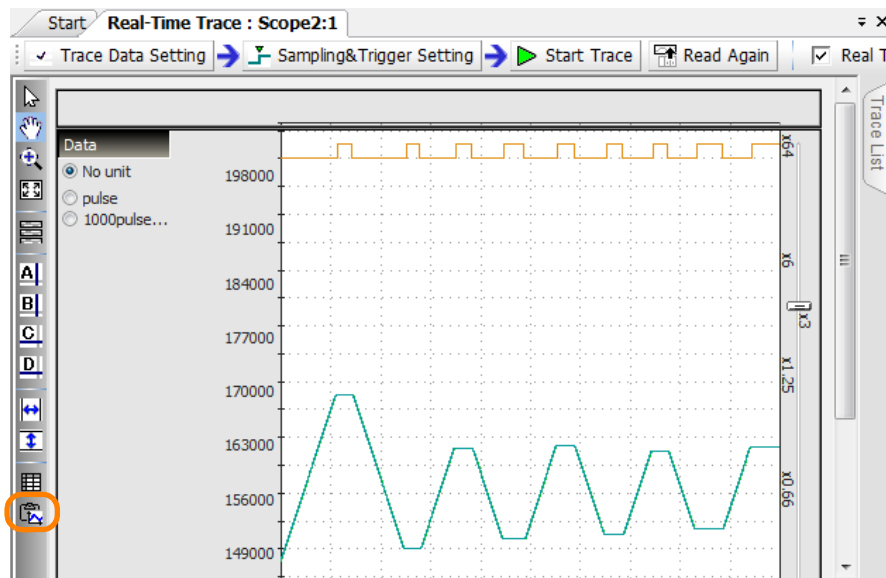
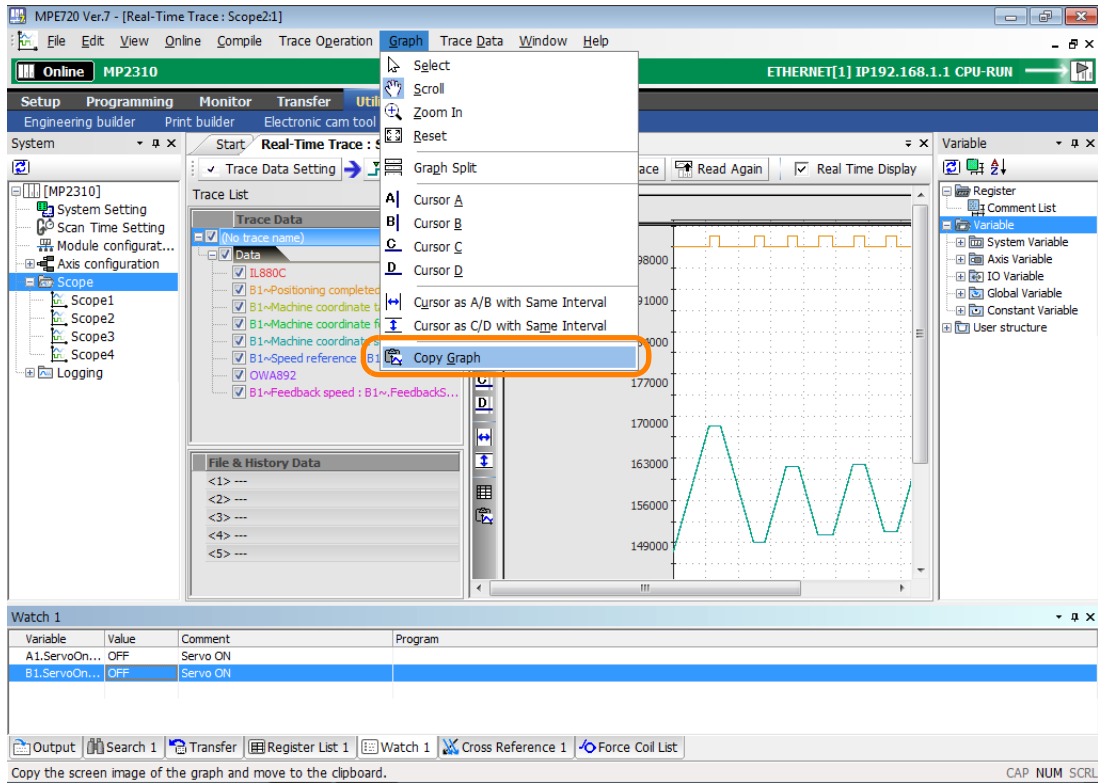

XY Trace

An XY trace gets the position data (target position and feedback position) of the X and Y axes in every scan and displays them on a 2-dimensional plane graph, allowing for visual analysis of the paths that the two axes take.

◆ Names and Functions of the XY Trace Tab Page Items

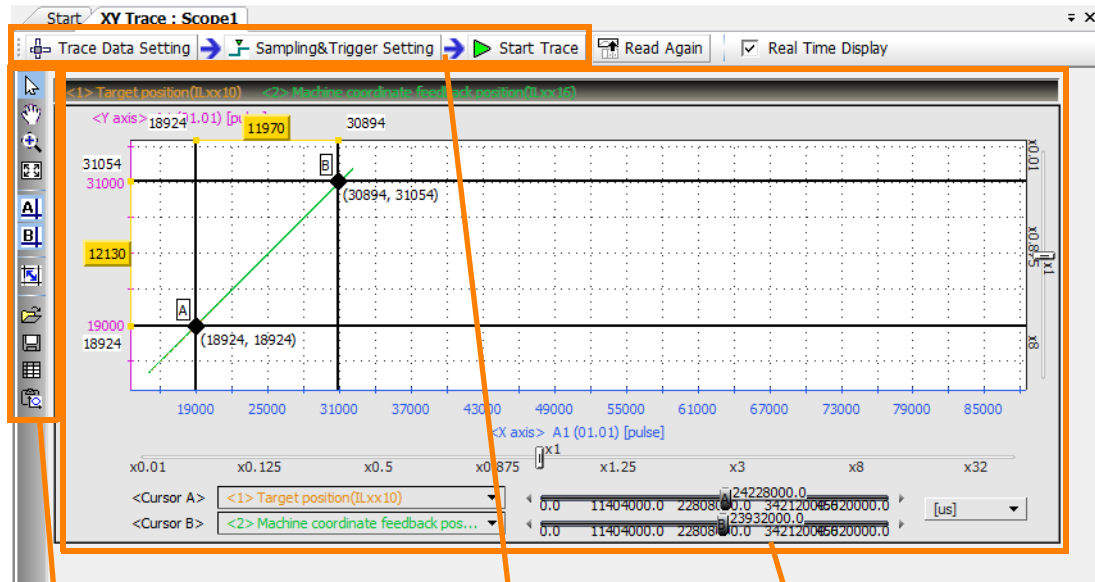

Graph Toolbar

The Graph Toolbar contains buttons to analyze the trace data.

Trace Execution Toolbar

This toolbar contains the **Trace Data Setting**, the **Sampling & Trigger Setting**, and the **Start Trace** Buttons to perform these operations in this order.

XY Graph

This graph displays the trace data. You can use the Graph Toolbar, the sliders, and the cursors to analyze the XY trace data.

■ Graph Toolbar

The following table gives details on the icons.

Icon	Function
	Click the Select Icon, and then double-click the target area to enlarge the display.
	Click the Scroll Icon to move the target area. Double-click the target area to enlarge the display.
	Click the Zoom In Icon, and then drag or double-click the target area to enlarge the display.
	Click the Reset Icon to return to the original display of the graph.
	Click the Cursor A Icon to display cursor A, and then move it on the graph to display the X and Y values.
	Click the Cursor B Icon to display cursor B, and then move it on the graph to display the X and Y values.
	Click the Cursor AB Link Icon to lock the horizontal distance between cursors A and B, and to move them together at a fixed width.
	Click the Open External File Icon to display the Open Dialog Box and read the trace data from a file.
	Click the Save Icon to display the Save Dialog Box so that you can save the file with a specified name.
	Click the List Icon to display the Trace List.
	Click the Copy Graph Icon to place a screen capture of the graph on the clipboard.

■ Trace Execution Toolbar

• Trace Data Settings

Use this button to select the axes and the trace targets.

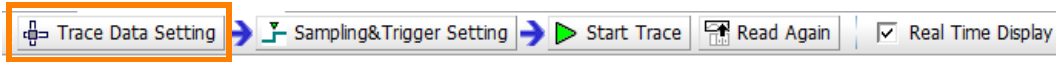

Click the **Trace Data Setting** Button to display the following dialog box:

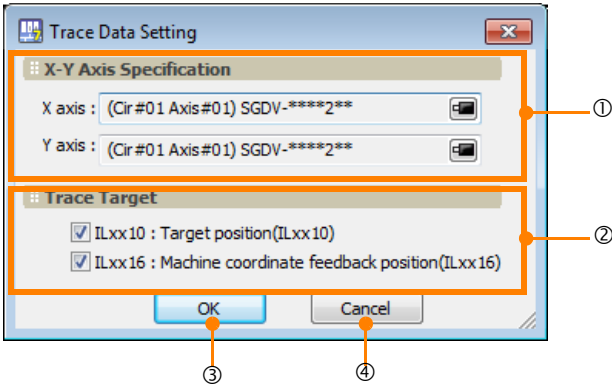

No.	Item	Description
①	X-Y Axis Specification	Use these boxes to specify the X and Y axes.
②	Trace Target	Use these check boxes to specify the trace targets. You can select the following two motion parameters: ILxx10: Machine Coordinate System Calculated Position (ILxx10) ILxx16: Machine Coordinate System Feedback Position (ILxx16)
③	OK	The OK Button sets the X-Y axes and the trace targets, and enables the Sampling & Trigger Setting Button.
④	Cancel	The Cancel Button returns you to the XY Trace Dialog Box without setting the X-Y axes and the trace targets.

• Sampling and Trigger Settings

This dialog box is used to set the trace name, the sampling settings, and the trigger setting parameters.

Refer to the following section for details on sampling and trigger settings.

📖 *Realtime Tracing – Sampling and Trigger Settings* on page 5-42

• Starting and Stopping Traces

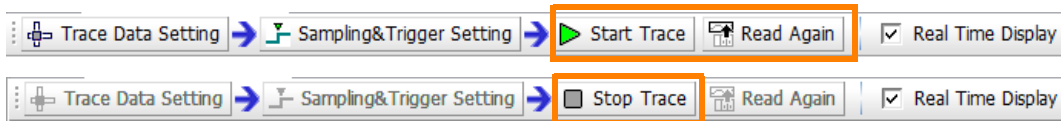

Function	Description
Start Trace	Use this button to start the trace. The data that is sampled will be displayed in realtime.
Real Time Display	Select the Real Time Display Check Box to display the axes moving in realtime. If more than one Trace Tab Page is open, you can use a realtime display for only one of them.
Stop Trace	Use this button to stop the trace. When the trace stops, all trace buffer data will be collected and displayed.

5.4 Tuning

This section describes how to perform tuning for the machine that is connected to the Machine Controller.

5.4.1 Using SigmaWin+ (When Using a Servo)

The Servo can be tuned by connecting it to the SigmaWin+ via the Controller.

Refer to the following manual for details.

 SigmaWin+ Online Manual (Manual No.: SIEP S800000 67)

5.4.2 Using DriveWizard Plus (When Using an Inverter)

The Inverter can be tuned by connecting it to the DriveWizard Plus via the Controller.

Refer to the following manual for details.

 DriveWizard Plus Online Manual (Manual No.: TOEP C730600 20)

Security

6

This chapter describes the security features.

6.1	Project File Security	6-2
6.1.1	Setting a Project Password	6-2
6.1.2	Creating or Changing a Password	6-2
6.1.3	Deleting a Password	6-3
6.1.4	Setting the Default User	6-4
6.1.5	User Management	6-4
6.2	Program Security	6-7
6.2.1	Setting the Password	6-7
6.2.2	Changing a Password	6-8
6.2.3	Deleting a Password	6-8
6.2.4	Opening a Password-Protected Ladder Program	6-9
6.3	Online Security	6-10
6.3.1	Setting Online Security	6-11
6.3.2	Changing Online Security	6-12
6.3.3	Deleting Online Security	6-13
6.3.4	Changing the Security Key	6-14
6.3.5	Unlocking Online Security Temporarily	6-15

6.1 Project File Security

This section describes the security features for project files.

6.1.1 Setting a Project Password

You can set a password for the project file that is currently open.



If you forget the password that you set, there is no way to recover it and it will be impossible to open the password-protected project file.

6.1.2 Creating or Changing a Password

1. Select **Security** and then **Project Password** from the tree structure in the Environment Setting Dialog Box. The following view will be displayed.

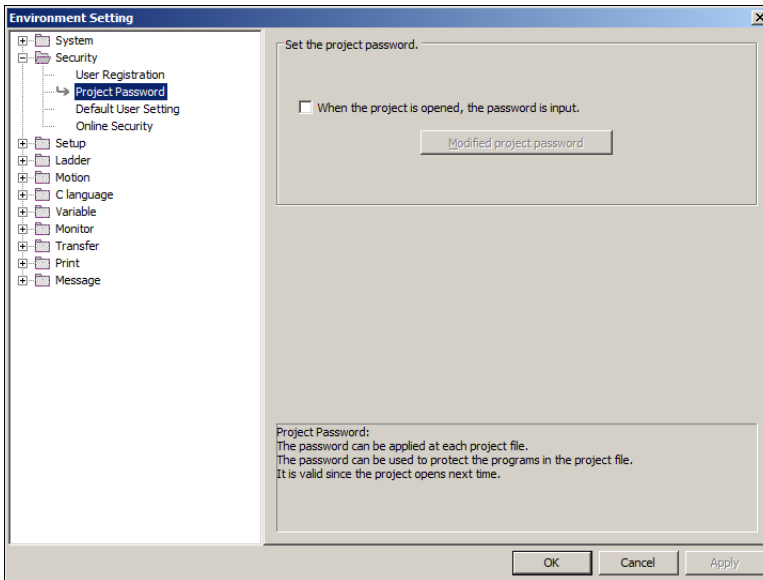

2. Select the **When the project is opened, the password is input** Check Box on the Project Password View. The following dialog box will be displayed. Enter each item, and then click the **OK** Button.

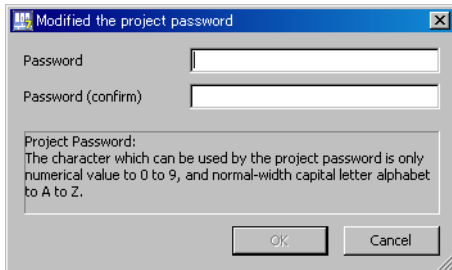

Item	Description
Password	Enter from 1 to 16 alphanumeric characters. The password is not case sensitive.
Password (confirm)	Enter the same password one more time, and then click the OK Button. Note: The OK Button will be enabled when one or more characters are entered in the Password (confirm) Box.

6.1.3 Deleting a Password

Clear the selection of the **When the project is opened, the password is input** Check Box on the Project Password View of the Environment Setting Dialog Box to delete the password that you set previously.

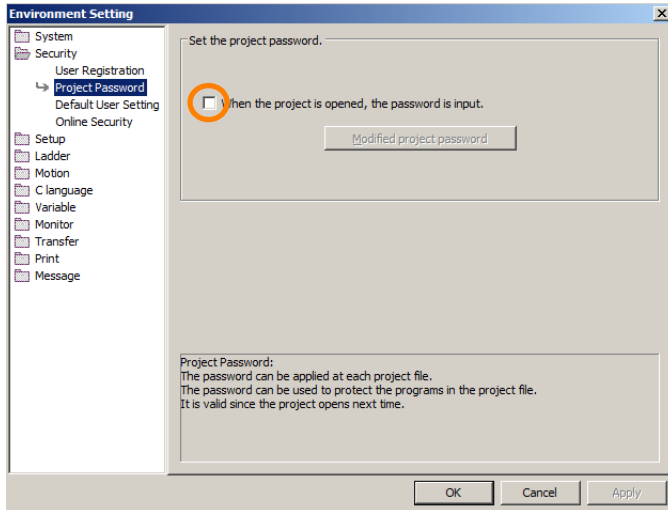

Information When you try to open a password-protected project file, the Security Dialog Box will be displayed.

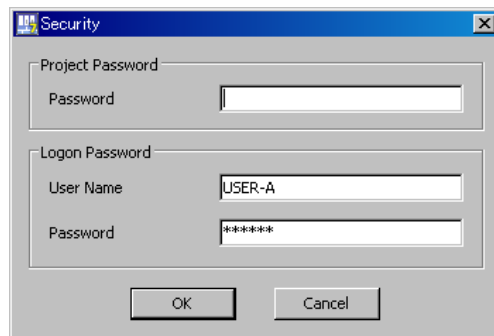

Enter the project password, and then click the **OK** Button to open the project file.

6.1.4 Setting the Default User

Select **Security** and then **Default User Setting** from the tree structure in the Environment Setting Dialog Box. The Default User Setting View will be displayed.

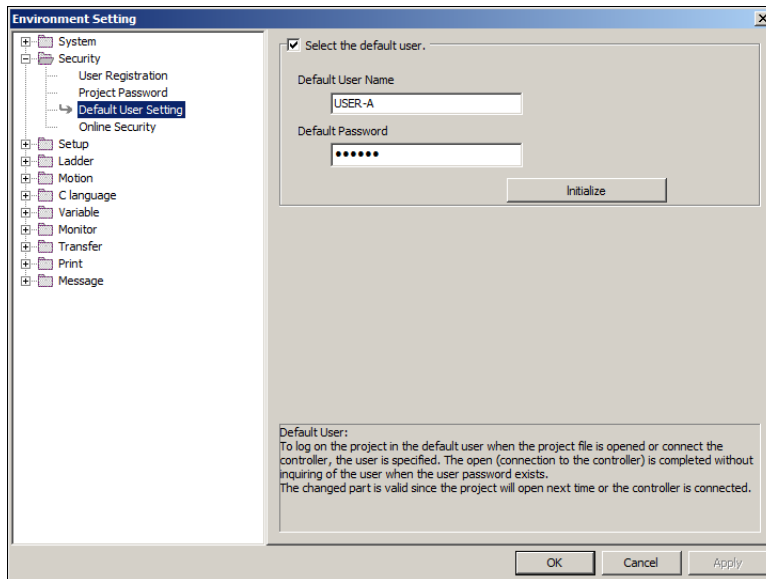

Select the **Select the default user** Check Box to enable accessing the project file (or the Machine Controller) with the default user account. If the specified user name is not among the registered users, the Logon Dialog Box will be displayed.

Enter from 1 to 16 alphanumeric characters into the **Default User Name** and **Default Password** Boxes.

6.1.5 User Management

You can register and change the name of users who can open a project file.

You can make this setting when the project file is open, or when the Machine Controller is online. If the setting is performed while the Machine Controller is online, the setting will provide access and writing privileges to the Machine Controller.



Important If you forget the password that you set, there is no way to recover it and it will be impossible for the user to open the password-protected project file.

Select **Security** and then **User Registration** from the tree structure in the Environment Setting Dialog Box. The User Registration View will be displayed.

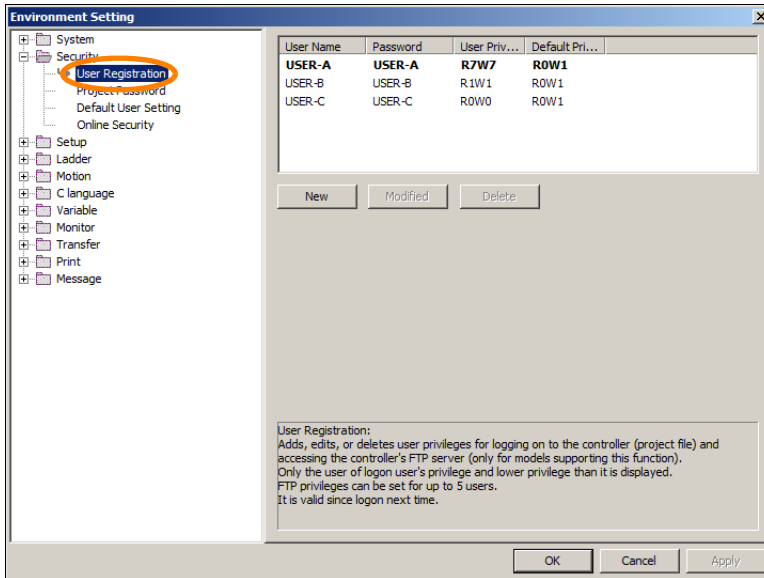

Registering a New User

Click the **New** Button on the User Registration View. The User Registration Dialog Box will be displayed. Enter each item, and then click the **OK** Button.

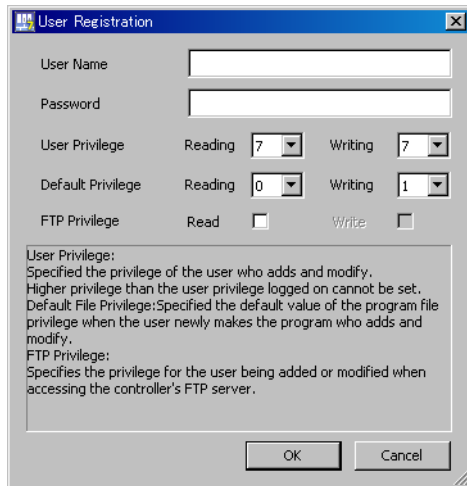

User Name	Enter from 1 to 16 alphanumeric characters.
Password	Enter from 1 to 16 alphanumeric characters.
User Privilege	Select the reading and writing privilege levels for the user from 0 to 7. Higher numbers represent higher levels of privileges.
Default Privilege	In these boxes, set the default levels of privileges when a user creates a program.



Important

Reading and Writing Privileges

Reading and writing privilege levels are set to maintain the security of the programs. To open a program, the user must have at least the same reading level privilege as was set for that program. Similarly, to edit and save a program, the user must have at least the same writing level privilege as was set for that program.

Changing Registration Information

Select the user whose information you want to change in the User Registration Pane of the Environment Setting Dialog Box. The User Registration Dialog Box will be displayed. Set the items as needed, and then click the **OK** Button to change the user information.

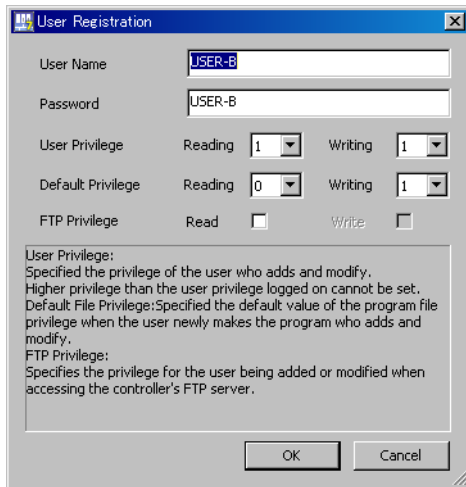

Information If the selected user is the default user, only the default privileges can be changed. Refer to the following section for information on specifying the default user.

 [Setting the Default User \(page 6-4\)](#)

Deleting a Registered User

Select the user whose information you want to delete in the User Registration View of the Environment Setting Dialog Box. The following dialog box will be displayed. Click the **OK** Button to delete the selected user.

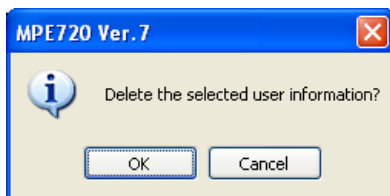

6.2 Program Security

You can set separate passwords for ladder programs and motion programs. A lock mark is displayed for each password-protected program. To edit a password-protected program, you must first enter the password.

The purpose of this password is to control access for editing. It does not affect the management of program files (copying, cutting, pasting, deleting, or enable/disable settings).



If you forget the password that you set, there is no way to recover it, and it will be impossible to open the password-protected program.

Important

This section describes the security that is provided, using a ladder program as an example.

6.2.1 Setting the Password

1. In the Ladder Pane, right-click on the program for which you want to set a password. Select **Set the Password** from the pop-up menu. The Program Password Dialog Box will be displayed.



2. Enter 1 to 8 characters in the **New Password** Box. Enter the same password again in the **Password (Confirm)** Box, and then click the **OK** Button.

Note: 1. The **OK** Button will be enabled when one or more characters are entered in the **Password (Confirm)** Box.

2. The password is not case sensitive.

The Program Password Dialog Box will be closed, and a padlock icon will be displayed next to the ladder program that was selected in Step 1. If the program was displayed in the main window, it will be closed.

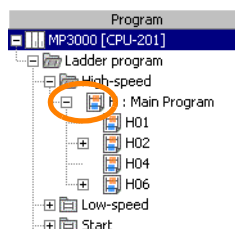

6.2.2 Changing a Password

1. In the Ladder Pane, right-click on the program for which you want to change the password. Select **Set the Password** from the pop-up menu. The Program Password Dialog Box will be displayed.

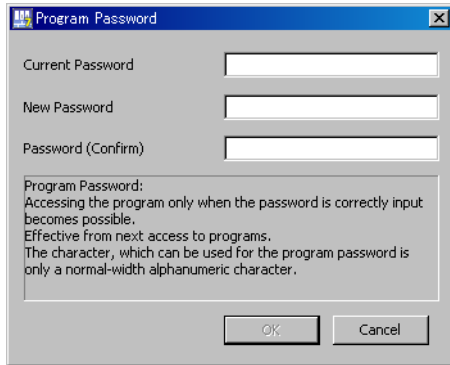

2. Enter the current password in the **Current Password** Box. Enter 1 to 8 characters in the **New Password** Box. Enter the same password again in the **Password (Confirm)** Box, and then click the **OK** Button.

Note: The **OK** Button will be enabled when one or more characters are entered in the **Password (Confirm)** Box.

The password will be changed and the Program Password Dialog Box will be closed.

6.2.3 Deleting a Password

1. In the Ladder Pane, right-click on the program from which you want to delete the password. Select **Cancel the Password** from the pop-up menu. The Program Password Dialog Box will be displayed.



2. Enter the current password in the **Program Password** Box, and then click the **OK** Button.

Note: The **OK** Button will be enabled when one or more characters are entered in the **Program Password** Box.

The padlock icon will be removed from the ladder program that was selected in step 1, and the Program Password Dialog Box will be closed.

6.2.4 Opening a Password-Protected Ladder Program

1. When you attempt to open a password-protected ladder program (i.e., one with a padlock icon next to its name), the Program Password Dialog Box will be displayed.



2. Enter the current password in the **Program Password** Box, and then click the **OK** Button.

Note: The **OK** Button will be enabled when one or more characters are entered in the **Program Password** Box.

The selected ladder program will be opened in the main window.

6.3 Online Security

Online security refers to limiting the ability to read data from the Machine Controller. You can set security key (i.e., a password) and privilege levels for programs to restrict the ability to read the program data from the Machine Controller or to open the programs to users who have at least the specified level of file reading privilege.

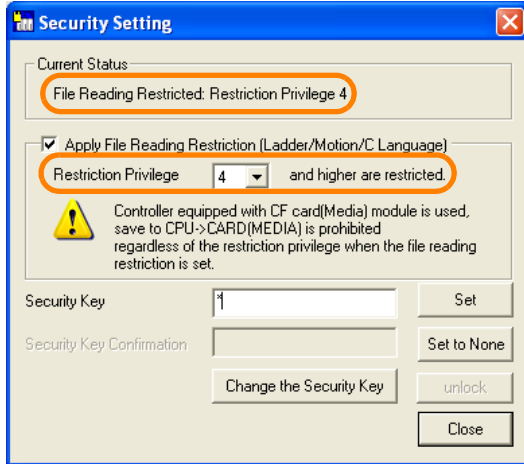

Item	Description
Status	This area displays the current status of the security setting.
Apply File Reading Restriction	Select this check box to apply a reading restriction. This check box can be used to set file reading restrictions for ladder programs, motion programs, and C programs. Note: If a value is entered in the Security Key Box without selecting the Apply File Reading Restriction Check Box, only the security key will be set. The file reading restriction will not be set.
Restriction Privilege	Use this box to set the privilege level to restrict the group of users who can read the files. Note: The user must have a privilege level at least as high as the specified privilege to read the files.
Security Key and Security Key Confirmation	Enter the password that will be required to set online security. Enter from 1 to 8 alphanumeric characters. The password is case sensitive.
Change the Security Key Button	Click this button to change the security key.
Set Button	Click this button to set the file reading restriction.
Set to None Button	Click this button to delete the current security key setting.
Unlock Button	Click this button to temporarily unlock the current online security. Even if you save the settings to the flash memory while the security key is temporarily unlocked, the temporary unlocked status will not be saved, and the online security setting will be maintained. The temporary unlock will be valid until you turn OFF the power supply to the Controller, disconnect the MPE720 from the Controller, or press the Lock Button on the Security Setting Dialog Box.
Close Button	Click this button to close the Security Setting Dialog Box.



Important

1. If the reading privilege is set to 4, then programs with a reading privilege of 4 or higher cannot be opened.
To manage program security, the current user must have a writing privilege level of 7.
2. Even if the **Apply File Reading Restriction** Check Box is selected while the CARD and SAVE pins of the DIP switch on the MP2200 Machine Controller with the CPU-02 are set to ON, the restriction will not be saved to the CF card. Refer to the following manual on the MP2200 Machine Controller.
 MP2200 User's Manual (Manual No.: SIEP C880700 14)

6.3.1 Setting Online Security

This section describes how to set restrictions on reading the data from the Machine Controller. Use the following procedure to set online security.

1. With the Machine Controller online, select **Online – Security Setting** from the menu bar. The Security Setting Dialog Box will be displayed.

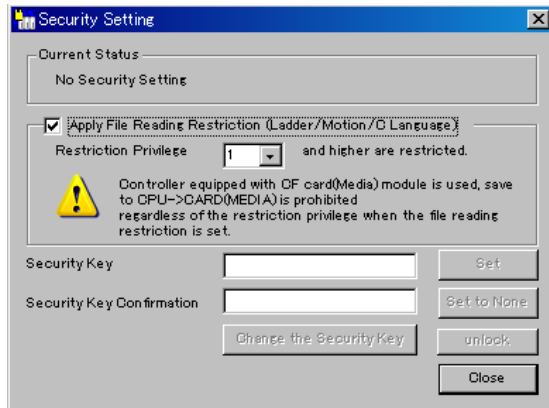

2. Select the **Apply File Reading Restriction** Check Box, and then select the value of the **Restriction Privilege** Box from the list.
3. Enter the password in the **Security Key** Box. Enter the same password again in the **Security Key Confirmation** Box, and then click the **Set** Button. The **Set** Button will be enabled when one or more characters of text are entered in the **Security Key** Box. The file reading restriction and the security key will be changed, and the following message will be displayed to ask for confirmation.

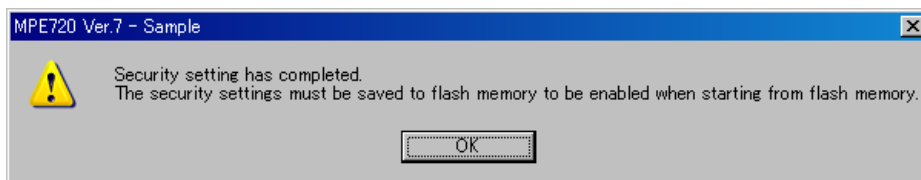

4. Click the **OK** Button. Click the **Close** Button to close the **Security Setting** Dialog Box. Save to flash memory, if necessary.

6.3.2 Changing Online Security

This section describes how to change the online security settings.

Use the following procedure to change the current file reading restriction and restriction privilege settings.

1. With the Machine Controller online, select **Online – Security Setting** from the menu bar. The Security Setting Dialog Box will be displayed.

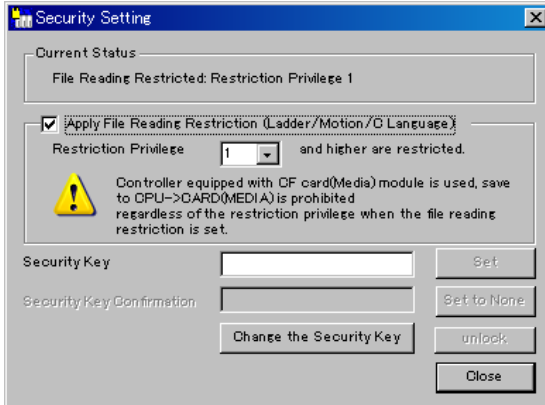

2. Select or clear the **Apply File Reading Restriction** Check Box, and then change the value of the **Restriction Privilege** Box.
3. Enter the current security key in the **Security Key** Box, and then click the **Set** Button. The following confirmation message will be displayed.

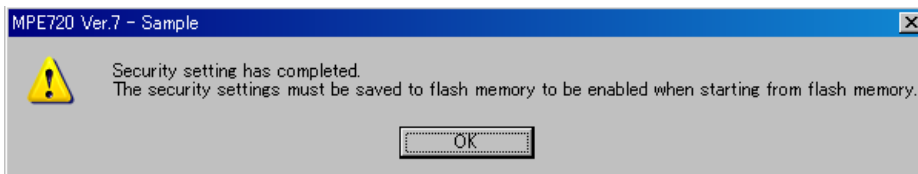

4. Click the **OK** Button.
Click the **Close** Button to close the **Security Setting** Dialog Box. Save to flash memory, if necessary.

6.3.3 Deleting Online Security

This section describes how to delete the online security settings.

Use the following procedure to delete the security that was set for the Machine Controller.

1. With the Machine Controller online, select **Online – Security Setting** from the menu bar. The Security Setting Dialog Box will be displayed.

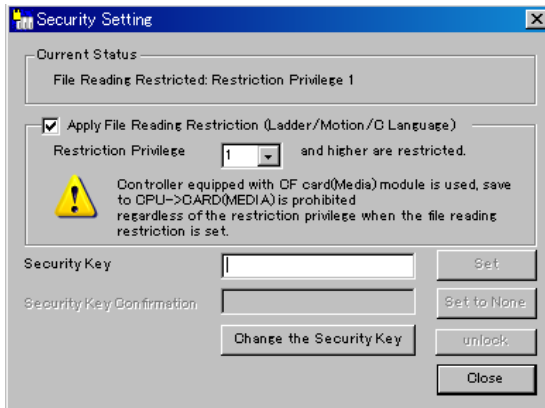

2. Enter the current security key in the **Security Key** Box, and then click the **Unlock** Button. The following confirmation message will be displayed.

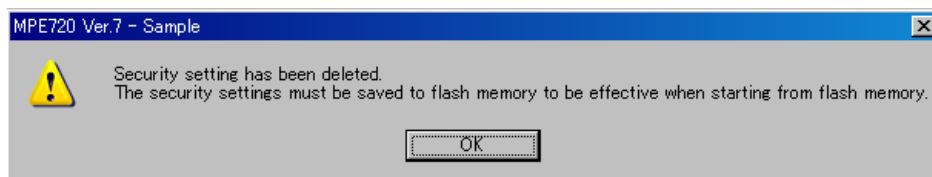

3. Click the **OK** Button. Click the **Close** Button to close the **Security Setting** Dialog Box. Save to flash memory, if necessary.

6.3.4 Changing the Security Key

This section describes how to change the security key of the online security.

Use the following procedure to change the security key.

1. With the Machine Controller online, select **Online – Security Setting** from the menu bar. The Security Setting Dialog Box will be displayed.



2. Click the **Change the Security Key** Button. The Security Key Change Dialog Box will be displayed.

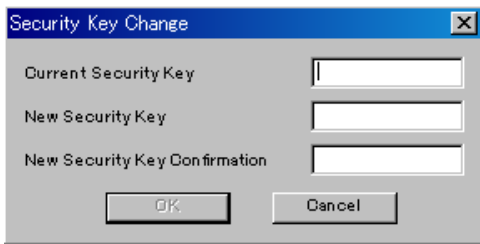

3. Enter the current password in the **Current Security Key** Box, and then enter the new password in the **New Security Key** Box. Enter the same new password in the **New Security Key Confirmation** Box, and then click the **OK** Button. The following confirmation message will be displayed.

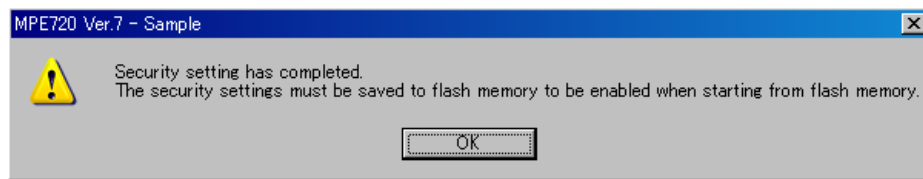

4. Click the **OK** Button. Click the **Close** Button to close the **Security Setting** Dialog Box. Save to flash memory, if necessary.

6.3.5 Unlocking Online Security Temporarily

This section describes how to temporarily unlock the online security settings.

Use the following procedure to temporarily unlock the security that was set for the Machine Controller.

1. With the Machine Controller online, select **Online – Security Setting** from the menu bar. The Security Setting Dialog Box will be displayed.

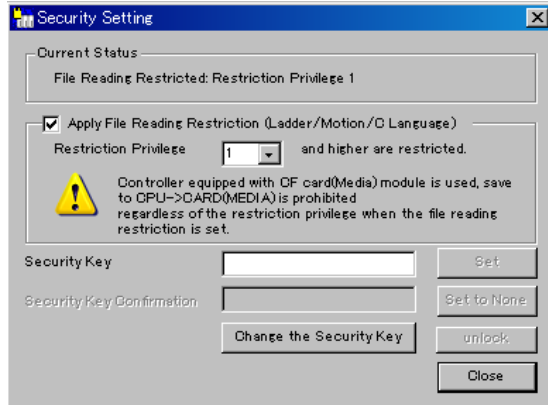

2. Enter the current security key in the **Security Key** Box, and then click the **Unlock** Button.

The following confirmation message will be displayed.

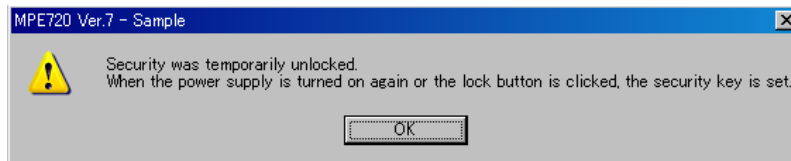

3. Click the **OK** Button.

Click the **Close** Button to close the **Security Setting** Dialog Box.

Even if you save the settings to the flash memory, the temporary unlocked status will not be saved, and the online security setting will be maintained.

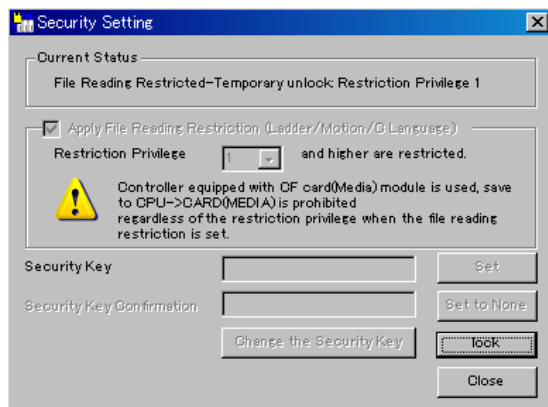

Controller Installation and Operating Conditions

Appendix **A**

This chapter describes conditions when the MP2000-series Machine Controllers are used.

A.1	General Specifications	A-2
A.1.1	Environmental Conditions	A-2
A.1.2	Mechanical Operating Conditions	A-2
A.1.3	Electrical Operating Conditions	A-2
A.2	EMC Installation Conditions	A-3

A.1 General Specifications

A.1.1 Environmental Conditions

Item	Specification
Ambient Operating Temperature	0 to 55°C (CPU-03: 0 to 50°C)
Ambient Storage Temperature	-25 to 85°C
Ambient Operating Humidity	30% to 95% RH (with no condensation)
Ambient Storage Humidity	5% to 95% RH (with no condensation)
Pollution Degree	Conforms to JIS B 3502 Pollution Degree 2.
Corrosive Gases	There must be no combustible or corrosive gases.
Operating Altitude	2,000 m max.

Control Panel Cooling Method

The components that are used in the Machine Controller require the ambient operating temperature to be between 0 and 55°C. Use the following methods to ensure adequate cooling in the control panel.

◆ Control Panels with Natural Cooling

- Do not mount the Machine Controller at the top of the control panel, where the hot air that is generated inside the panel collects.
- Leave sufficient space above and below the Units, and maintain adequate distances from other devices, cable ducts, and other objects to ensure suitable air circulation.
- Do not mount the Controller in any direction other than the specified direction.
- Do not mount the Controller on top of any device that generates a significant amount of heat.
- Do not subject the Controller to direct sunlight.

A.1.2 Mechanical Operating Conditions

Item	Specification
Vibration Resistance	Conforms to JIS B 3502. Vibration amplitude and acceleration: 10 Hz ≤ f < 57 Hz with vibration amplitude of 0.075 mm 57 Hz ≤ f ≤ 150 Hz with fixed acceleration of 9.8 m/s ² 10 sweeps each in X, Y, Z directions (sweep: 1 octave/min)
Shock Resistance	Conforms to JIS B 3502. Peak acceleration of 147 m/s ² twice for 11 ms each in the X, Y, and Z directions

A.1.3 Electrical Operating Conditions

Item	Specification
Noise Resistance	Conforms to EN 61000-6-2, EN 61000-6-4, EN 55011 (Group1 Class A)

A.2 EMC Installation Conditions

This section gives the installation conditions that were used for EMC certification testing. The EMC level may change depending on the actual installation configuration, wiring conditions, or other conditions. These Yaskawa products are designed to be built into equipment. Therefore, you must implement EMC measures and confirm compliance for the final equipment.

The applicable standards are EN 55011 group 1 class A, EN 61000-6-2, EN 61000-6-4 and EN 61131-2 Zone B.

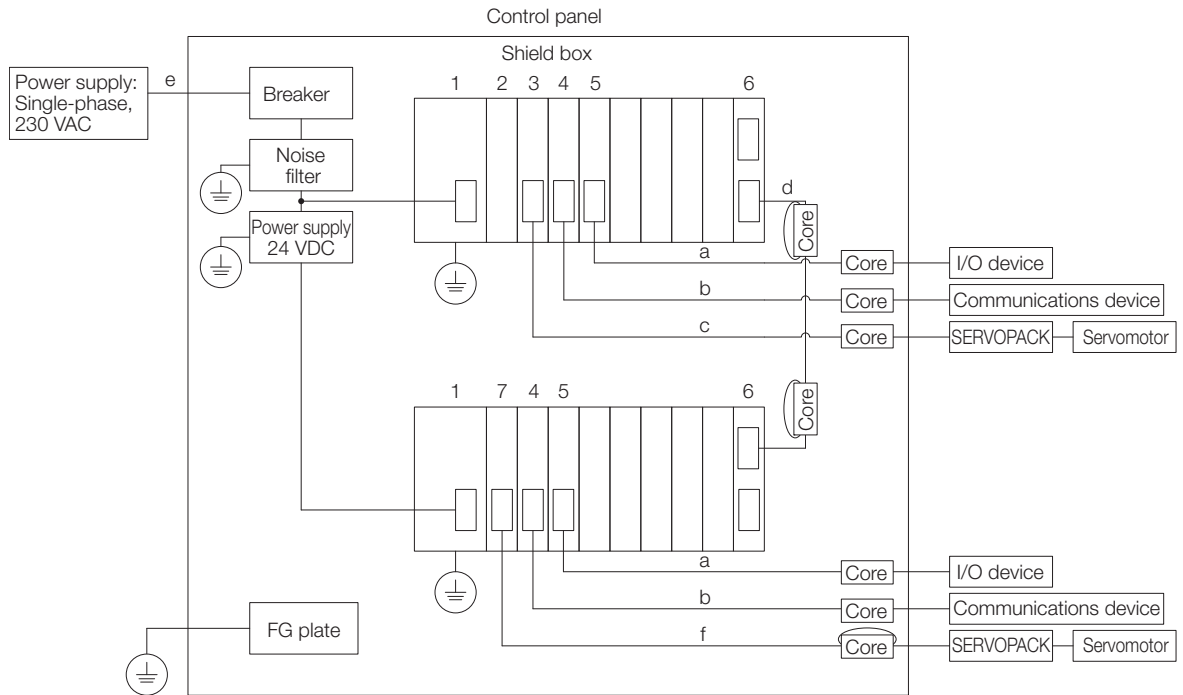

Number	Name
1	Base Unit
2	CPU Module
3	Motion Module
4	Communications Module
5	I/O Module
6	Expansion Interface Module
7	MECHATROLINK Motion Module

Letter	Cable Name	Specification	Remarks
a	I/O Signal Cable	Shielded cable	–
b	Communications Cable	Shielded cable	Select the cables according to the cable specifications in the User's Manual for each Module.
c	SERVOPACK Cable	Shielded cable	–
d	Rack Expansion Cable	Shielded cable	Do not remove the ferrite cores from the Cable.
e	Power Cable	Shielded cable	–
f	MECHATROLINK Cable	Shielded cable	–

- Note: 1. Electrically connect the control panel box and door.
 2. Attach ferrite cores at the entrance to the panel for any cables connected to devices outside the control panel.
 3. Connect the FG for devices inside the control panel to the mounting panel. Keep the FG lines as short as possible.
 4. Attach ferrite cores that are delivered with any product according to the installation instructions for the product.

Motion Parameters

Appendix **B**



This appendix lists the motion parameters.

B.1	Fixed Parameters	B-2
B.2	Setting Parameters	B-5
B.3	Monitor Parameters	B-13

B.1 Fixed Parameters

The following table lists the SVB, SVC, and SVR fixed parameters.

Refer to the following manual for details on individual fixed parameters.

-  MP2000 Series SVA-01 Motion Module User's Manual (Manual No.: SIEP C880700 32)
-  MP2000 Series Built-in SVB/SVB-01 Motion Module User's Manual (Manual No.: SIEP C880700 33)
-  MP2000 Series SVC-01 Motion Module User's Manual (Manual No.: SIEP C880700 41)

No.	Name	Description	SVB	SVC	SVR
0	Operation Mode Selection	0: Normal Operation Mode	√	√	√
		1: Unused Axis (Axis unused)	√	√	√
		2: Simulation Mode	√	√	–
		3: SERVOPACK Transmission Reference Mode	√	√	–
		4 and 5: Reserved for system.	–	–	–
1	Function Selection Flags 1	Bit 0: Axis Selection 0: Finite-length axis, 1: Infinite-length axis*1	√	√	√
		Bit 1: Enable Positive Software Limit (Soft limit (positive direction) enable/disable) 0: Disabled, 1: Enabled	√	√	–
		Bit 2: Enable Negative Software Limit (Soft limit (negative direction) enable/disable) 0: Disabled, 1: Enabled	√	√	–
		Bit 3: Enable Positive Overtravel (Overtravel positive direction enable/disable) 0: Disabled, 1: Enabled	√	√	–
		Bit 4: Enable Negative Overtravel (Overtravel negative direction enable/disable) 0: Disabled, 1: Enabled	√	√	–
		Bits 5 to 7: Reserved for system.	–	–	–
		Bit 8: Interpolation Segment Distribution Processing 0: Enabled, 1: Disabled	√	√	–
		Bit 9: Simple Absolute Infinite Axis Position Management (Simple ABS rotary Pos. mode) 0: Disabled, 1: Enabled	√	√	–
		Bit A: SERVOPACK Parameter Auto-Write (User constants self-writing function) 0: Enabled, 1: Disabled	√	√	–
		Bit B: User-specified SERVOPACK Parameter Auto-Write (User select User constants self-writing function) 0: Disabled, 1: Enabled	√	√	–
		Bit C: Software Limit Parameter Selection (Soft limit parameter selection) 0: Fixed parameter, 1: Setting parameter	√	√	–
		Bits D to F: Reserved for system.	–	–	–

Continued on next page.

*1. Always set this parameter to 0 for linear motors.

Continued from previous page.

No.	Name	Description	SVB	SVC	SVR
2	Function Selection Flags 2	Bit 0: Mask Communications Error Detection (Communication abnormality detection mask) 0: Disabled, 1: Enabled	√	√	–
		Bit 1: Mask Watchdog Error Detection (WDT abnormality detection mask) 0: Disabled, 1: Enabled	√	√	–
		Bits 2 to F: Reserved for system.	–	–	–
3	–	Reserved for system.	–	–	–
4	Reference Unit Selection*2	0: Pulses 1: mm 2: Degrees 3: Inches 4: μm	√	√	√
5	Number of Digits Below Decimal Point	1 = 1 digit	√	√	√
6	Travel Distance per Machine Rotation (Rotary Motor)	1 = 1 reference unit	√	√	√
	Linear Scale Pitch (Linear Motor)	1 = 1 reference unit	√	√	√
8	Servomotor Gear Ratio Term*3	1 = 1 revolution	√	√	√
9	Machine Gear Ratio Term*3	1 = 1 revolution	√	√	√
10	Infinite-length Axis Reset Position (POS-MAX)*3	1 = 1 reference unit	√	√	√
12	Positive Software Limit	1 = 1 reference unit	√	√	–
14	Negative Software Limit	1 = 1 reference unit	√	√	–
16 to 28	–	Reserved for system.	–	–	–
29	Motor Type Selection	0: Rotary motor 1: Linear motor	√	√	√
30	Encoder Selection	0: Incremental encoder 1: Absolute encoder 2: Absolute encoder used as incremental encoder (Absolute encoder (Incremental encoder is used)) 3: Reserved for system.	√	√	–
31 to 33	–	Reserved for system.	–	–	–

Continued on next page.

*2. For linear motors, you can use 0 (pulses), 1 (mm), or 4 (μm). If 2 (degrees) or 3 (inches) is selected, the unit is converted to mm.

*3. This parameter is not valid for linear motors.

Continued from previous page.

No.	Name	Description	SVB	SVC	SVR
34	Rated Motor Speed (Rotary Motor)	1 = 1 min ⁻¹	√	√	√
	Rated Speed (Linear Motor)	1 = 0.1 m/s	√	√	√
36	Number of Pulses Per Motor Rotation (Rotary Motor)	1 = 1 pulse/rev	√	√	√
	Number of Pulses Per Linear Scale Pitch (Linear Motor)	1 = 1 pulse/scale pitch	√	√	√
38	Maximum Number of Absolute Encoder Rotations ^{*4*5}	1 = 1 revolution	√	√	–
40 to 41	–	Reserved for system.	–	–	–
42	Feedback Speed Movement Averaging Time Constant	1 = 1 ms	√	√	√
43	–	Reserved for system.	–	–	–
44	User-specified SER- VOPACK Parameter Number	Specifies the SERVOPACK parameter number to apply automatically.	√	√	–
45	User-specified SER- VOPACK Parameter Size	Specifies the data size of the above SERVO- PACK parameter. 1 = 1 W	√	√	–

*4. This parameter is not valid for linear motors.

*5. Set this parameter to 0 when a direct-drive motor is used.

B.2 Setting Parameters

The following table lists the SVB, SVC, and SVR setting parameters.

Refer to the following manual for details on individual setting parameters.

 MP2000 Series SVA-01 Motion Module User's Manual (Manual No.: SIEP C880700 32)

 MP2000 Series Built-in SVB/SVB-01 Motion Module User's Manual (Manual No.: SIEP C880700 33)

 MP2000 Series SVC-01 Motion Module User's Manual (Manual No.: SIEP C880700 41)

Register Address	Name	Description	SVB	SVC	SVR
OW□□□00	Operation Command Settings	Bit 0: Servo ON 0: OFF, 1: ON	√	√	√
		Bit 1: Machine lock 0: Machine lock mode released 1: Machine lock mode	√	√	—
		Bits 2 to 3: Reserved for system.	—	—	—
		Bit 4: Latch Detection Request (Latch detection demand) 0: OFF, 1: ON	√	√	—
		Bit 5: Reserved for system.	—	—	—
		Bit 6: Number of POSMAX Turns Preset Request (POSMAX turn number presetting demand) 0: OFF, 1: ON*1	√	√	√
		Bit 7: Absolute Infinite-length Position Information Load Request (Request ABS rotary pos. load) 0: OFF, 1: ON*1	√	√	—
		Bit 8: Positive External Torque/Force Limit Input (Forward outside limiting torque/thrust input) 0: OFF, 1: ON	√	√	—
		Bit 9: Negative External Torque/Force Limit Input (Reverse outside limiting torque/thrust input) 0: OFF, 1: ON	√	√	—
		Bit A: Reserved for system.	—	—	—
		Bit B: Reset Integration (Integration reset) 0: OFF, 1: ON	√	√	—
		Bit C: Reset Network (Network reset) 0: OFF, 1: ON	√	√	—
		Bit D: Latch Completed Status Clear Request (Latch completion status clear request) 0: OFF, 1: ON	√	√	—
		Bit E: Reset Communications (Communication reset) 0: OFF, 1: ON	√	√	—
		Bit F: Clear Alarm (Alarm clear) 0: OFF, 1: ON	√	√	√

Continued on next page.

*1. Always set this parameter to 0 for linear motors.

Continued from previous page.

Register Address	Name	Description	SVB	SVC	SVR
OW□□□01	Mode Settings 1	Bit 0: Excessive Deviation Error Level Setting 0: Alarm, 1: Warning	√	√	–
		Bits 1 to 2: Reserved for system.	–	–	–
		Bit 3: Speed Loop P/PI Switch 0: PI control, 1: P control	√	√	–
		Bit 4: Switch Gain (Gain switch) 0: OFF, 1: ON	√	√	–
		Bit 5: Switch Gain 2*2 (Gain switch 2) 0: OFF, 1: ON	√	√	–
		Bits 6 to F: Reserved for system.	–	–	–
OW□□□02	Mode Settings 2	Bits 0 to 7: Reserved for system.	–	–	–
		Bits 8 to F: Stop Mode Selection 0: Stop according to the Linear Deceleration Rate/Deceleration Time Constant parameter (Decelerate to a stop according to the linear deceleration time constant). 1: Stop immediately. (Stop reference output.)	√	√	–
OW□□□03	Function Settings 1	Bits 0 to 3: Speed Unit Selection 0: Reference units/s (Reference unit/sec) 1: 10 ⁿ reference units/min 2: Percentage of rated speed (1 = 0.01%) 3: Percentage of rated speed (1 = 0.0001%)	√	√	√
		Bits 4 to 7: Acceleration/Deceleration Rate Unit Selection 0: Reference units/s ² 1: ms	√	√	√
		Bits 8 to B: Filter Type Selection 0: No filter (Filter none) 1: Exponential acceleration/deceleration filter 2: Moving average filter	√	√	√
		Bits C to F: Torque Unit Selection 0: Percentage of rated torque (1 = 0.01%) 1: Percentage of rated torque (1 = 0.0001%)	√	√	√
OW□□□04	Function Settings 2	Bits 0 to 3: Latch Detection Signal Selection	√	√	–
		0: –	–	–	–
		1: –	–	–	–
		2: Phase-C pulse input signal	√	√	–
		3: /EXT1	√	√	–
		4: /EXT2	√	√	–
		5: /EXT3	√	√	–
		Bits 4 to 7: External Positioning Signal Setting	√	√	–
		0: –	–	–	–
		1: –	–	–	–
		2: Phase-C pulse input signal	√	√	–
		3: /EXT1	√	√	–
		4: /EXT2	√	√	–
		5: /EXT3	√	√	–
Bits 8 to F: Reserved for system.	–	–	–		

Continued on next page.

*2. Currently under development.

Continued from previous page.

Register Address	Name	Description	SVB	SVC	SVR
OW□□□□05	Function Settings 3	Bit 0: Reserved for system.	–	–	–
		Bit 1: Disable Phase Reference Calculation 0: Enabled, 1: Disabled	√	√	–
		Bits 2 to A: Reserved for system.	–	–	–
		Bit B: Zero Point Return Input Signal 0: OFF, 1: ON	√	√	–
		Bits C to F: Reserved for system.	–	–	–
OW□□□□06	M-III Vendor-specific Servo Command Output Signal	This parameter is used as a vendor-specific output area.	√	√	–
OW□□□□07	–	Reserved for system.	–	–	–
OW□□□□08 (Continued on next page.)	Motion Commands	0: NOP (No Operation) (No command)	√	√	√
		1: POSING (Positioning)	√	√	√
		2: EX_POSING (External Positioning)	√	√	√
		3: ZRET (Zero Point Return)	√	√	√
		4: INTERPOLATE (Interpolation)	√	√	√
		5: END_OF_INTERPOLATE (Last Interpolation Segment) (Reserved for system use.)	√	√	√
		6: LATCH (Latch) (Interpolation mode with latch input)	√	√	√
		7: FEED (Jog) (Jog mode)	√	√	√
		8: STEP (STEP Operation) (Relative position mode)	√	√	√
		9: ZSET (Set Zero Point)	√	√	√
		10: ACC (Change Acceleration Time)	√	√	√
		11: DCC (Change Deceleration Time)	√	√	√
		12: SCC (Change Filter Time Constant)	√	√	√
		13: CHG_FILTER (Change Filter Type)	√	√	√
		14: KVS (Change Speed Loop Gain)	√	√	–
		15: KPS (Change Position Loop Gain)	√	√	–
		16: KFS (Change Feedforward)	√	√	–
		17: PRM_RD (Read Parameter) (Read user constant)	√	√	–
		18: PRM_WR (Write Parameter) (Write user constant)	√	√	–
		19: ALM_MON (Monitor Alarms) (Alarm monitor)	√	√	–
		20: ALM_HIST (Monitor Alarm History) (Alarm history monitor)	√	√	–
		21: ALMHIST_CLR (Clear Alarm History)	√	√	–
		22: Reserved for system.	–	–	–
		23: VELO (Issue Speed Reference) (Speed reference)	√	√	√

Continued on next page.

Continued from previous page.

Register Address	Name	Description	SVB	SVC	SVR
OW□□□08 (Continued from previous page.)	Motion Commands	24: TRQ (Issue Torque/Force Reference) (Torque/Thrust reference)	√	√	√
		25: PHASE (Issue Phase Reference) (Phase reference)	√	√	√
		26: KIS (Change Position Loop Integral Time Constant)	√	√	–
		27: PPRM_WR (Write Non-volatile Parameter) (Stored parameter write)	√	√	–
		28 to 33: Reserved for system.	–	–	–
		34: EX_FEED (Jog with External Positioning) (Jog mode with external positioning)	√	√	–
		35: MEM_RD (Read Memory)	√	√	–
		36: MEM_WR (Write Memory)	√	√	–
		37: PMEM_RD (Read Non-volatile Memory)	√	√	–
		38: PMEM_WR (Write Non-volatile Memory)	√	√	–
OW□□□09	Motion Command Control Flags	Bit 0: Hold Command (Holds a command) 0: OFF, 1: ON	√	√	√
		Bit 1: Cancel Command (Interrupt a command) 0: OFF, 1: ON	√	√	√
		Bit 2: Travel Direction (Moving direction (JOG/STEP)) 0: Forward, 1: Reverse	√	√	√
		Bit 3: Zero Point Return Direction Selection 0: Reverse, 1: Forward	√	√	–
		Bit 4: Latch Zone Enable (Latch zone effective selection) 0: Disabled, 1: Enabled	√	√	–
		Bit 5: Position Reference Type 0: Incremental value addition method (Incremental value add method) 1: Absolute value specification method (Absolute value set method)	√	√	√
		Bit 6: Electric Cam Phase Compensation Type (Phase Compensation Type) 0: Incremental value addition method (Incremental value add method) 1: Absolute value specification method (Absolute value set method)	√	√	–
		Bit 7: Reserved for system.	√	–	–
		Bit 8: SERVOPACK Parameter Access Selection (Access target servo driver user constant) 0: Vendor-specific parameters 1: Common parameters	√	√	–
Bits 9 to F: Reserved for system.	–	–	–		

Continued on next page.

Continued from previous page.

Register Address	Name	Description	SVB	SVC	SVR
OW□□□0A	Motion Subcom- mands	0: NOP (No Operation)	√	√	√
		1: PRM_RD (Read Parameter) (Read user constant)	√	√	–
		2: PRM_WR (Write Parameter) (Write user constant)	√	√	–
		3: INF_RD (Read Device Information)	√	√	–
		4: SMON (Monitor Status)	√	√	–
		5: FIXPRM_RD (Read Fixed Parameter)	√	√	√
		6: FIXPRM_CHG (Change Fixed Parameter) (Write fixed parameter)	√	√	–
OW□□□0B	–	Reserved for system.	–	–	–
OL□□□0C	Torque/Force Reference Set- ting or Torque Feedforward Compensation	The unit is set in bits C to F (Torque Unit Selection) of OW□□□03.	√	√	√
OW□□□0E	Speed Limit for Torque/Force Reference	1 = 0.01% (percentage of rated speed)	√	√	–
OW□□□0F	–	Reserved for system.	–	–	–
OL□□□10	Speed Reference Setting	The unit is set in bits 0 to 3 (Speed Unit Selection) of OW□□□03.	√	√	√
OW□□□12	Speed Limit	1 = 0.01% (percentage of rated speed)	–	√	–
OW□□□13	–	Reserved for system.	–	–	–
OL□□□14	Torque/Force Limit	The unit is set in bits C to F (Torque Unit Selection) of OW□□□03.	√	√	–
OL□□□16	Second Speed Compensation	The unit is set in bits 0 to 3 (Speed Unit Selection) of OW□□□03.	√	√	√
OW□□□18	Override	1 = 0.01%	√	√	–
OW□□□19 to OW□□□1B	–	Reserved for system.	–	–	–
OL□□□1C	Position Refer- ence Setting	1 = 1 reference unit	√	√	√
OL□□□1E	Positioning Com- pletion Width	1 = 1 reference unit	√	√	–
OL□□□20	NEAR Signal Output Width	1 = 1 reference unit	√	√	–
OL□□□22	Excessive Devia- tion Detection Value	1 = 1 reference unit	√	√	–
OL□□□24	–	Reserved for system.	–	–	–
OW□□□26	Positioning Com- pletion Check Time	1 = 1 ms	√	√	–
OW□□□27	–	Reserved for system.	–	–	–
OL□□□28	Phase Compensa- tion Setting	1 = 1 reference unit	√	√	–
OL□□□2A	Latch Zone Lower Limit Set- ting	1 = 1 reference unit	√	√	–
OL□□□2C	Latch Zone Upper Limit Set- ting	1 = 1 reference unit	√	√	–
OW□□□2E	Position Loop Gain	1 = 0.1 /s	√	√	–

Continued on next page.

Continued from previous page.

Register Address	Name	Description	SVB	SVC	SVR
OW□□□2F	Speed Loop Gain	1 = 1Hz	√	√	–
OW□□□30	Speed Feedforward Compensation	1 = 0.01% (percentage of distribution segment)	√	√	–
OW□□□31	Speed Compensation	1 = 0.01% (percentage of rated speed)	√	√	√
OW□□□32	Position Loop Integral Time Constant	1 = 1 ms	√	√	–
OW□□□33	–	Reserved for system.	–	–	–
OW□□□34	Speed Loop Integral Time Constant	1 = 0.01 ms	√	√	–
OW□□□35	–	Reserved for system.	–	–	–
OL□□□36	Linear Acceleration Rate/Acceleration Time Constant	The unit is set in bits 4 to 7 (Acceleration/Deceleration Rate Unit Selection) of OW□□□03.	√	√	√
OL□□□38	Linear Deceleration Rate/Deceleration Time Constant	The unit is set in bits 4 to 7 (Acceleration/Deceleration Rate Unit Selection) of OW□□□03.	√	√	√
OW□□□3A	Filter Time Constant	1 = 0.1 ms	√	√	√
OW□□□3B	Bias Speed for Indexed Deceleration/Acceleration Filter	The unit is set in bits 0 to 3 (Speed Unit Selection) of OW□□□03.	√	–	√
OW□□□3C	Zero Point Return Method	0: DEC1 + C pulse 1: ZERO signal 2: DEC1 + ZERO signal 3: C pulse 4 to 10: Reserved for system. 11: C pulse only 12: P-OT + C pulse 13: P-OT only 14: HOME LS + C pulse 15: HOME only 16: N-OT + C pulse 17: N-OT only 18: INPUT + C pulse 19: INPUT only	√	√	–
OW□□□3D	Zero Point Position Output Width	1 = 1 reference unit	√	√	√
OL□□□3E	Approach Speed	The unit is set in bits 0 to 3 (Speed Unit Selection) of OW□□□03.	√	√	–
OL□□□40	Creep Speed	The unit is set in bits 0 to 3 (Speed Unit Selection) of OW□□□03.	√	√	–
OL□□□42	Zero Point Return Travel Distance	1 = 1 reference unit	√	√	–
OL□□□44	STEP Travel Distance	1 = 1 reference unit	√	√	√
OL□□□46	External Positioning Final Travel Distance	1 = 1 reference unit	√	√	–

Continued on next page.

Continued from previous page.

Register Address	Name	Description	SVB	SVC	SVR
OL□□□48	Zero Point Position Offset in Machine Coordinate System	1 = 1 reference unit	√	√	√
OL□□□4A	Working Coordinate System Offset	1 = 1 reference unit	√	√	√
OL□□□4C*3	Number of POS-MAX Turns Preset Data	1 = 1 revolution	√	√	√
OW□□□4E	SERVOPACK User Monitor Setting	Bits 0 to 3: Monitor 1 (Cannot be set.) Bits 4 to 7: Monitor 2 Bits 8 to B: Monitor 3 (Cannot be set.) Bits C to F: Monitor 4	√	√	–
OW□□□4F	SERVOPACK Alarm Monitor Number	Sets the number of the alarm to monitor.	√	√	–
OW□□□50	SERVOPACK Parameter Number	Sets the SERVOPACK parameter number.	√	√	–
OW□□□51	SERVOPACK Parameter Size	Sets the size of the SERVOPACK parameter in words.	√	√	–
OL□□□52	SERVOPACK Parameter Set Value	Sets the set value for the SERVOPACK parameter.	√	√	–
OW□□□54	Auxiliary SERVOPACK Parameter Number	Sets the SERVOPACK parameter number.	√	√	–
OW□□□55	Auxiliary SERVOPACK Parameter Size	Sets the size of the SERVOPACK parameter in words.	√	√	–
OL□□□56	Auxiliary SERVOPACK Parameter Set Value	Sets the set value for the SERVOPACK parameter.	√	√	–
OL□□□58	Address Setting	Sets the target address for the MEM_RD, MEM_WR, PMEM_RD, and PMEM_WR motion commands.	√	√	–
OW□□□5A	–	Reserved for system.	–	–	–
OW□□□5B	Device Information Selection Code	00 hex: Disabled 01 hex: Vendor ID code 02 hex: Device code 03 hex: Device version 04 hex: Device information file version 05 hex: Serial number	√	√	–
OW□□□5C	Fixed Parameter Number	Sets the number of the fixed parameter to read with the FIXPRM_RD motion subcommand.	√	√	√
OW□□□5D	–	Reserved for system.	–	–	–
OL□□□5E*4	Power OFF Encoder Position (Encoder position when power is off) (Lower 2 Words)	1 = 1 pulse	√	√	–

Continued on next page.

*3. This parameter is not valid for linear motors.

Continued from previous page.

Register Address	Name	Description	SVB	SVC	SVR
OL□□□60*4	Power OFF Encoder Position (Encoder position when power is off) (Upper 2 Words)	1 = 1 pulse	√	√	–
OL□□□62*4	Power OFF Pulse Position (Pulse position when power is off) (Lower 2 Words)	1 = 1 pulse	√	√	–
OL□□□64*4	Power OFF Pulse Position (Pulse position when power is off) (Upper 2 Words)	1 = 1 pulse	√	√	–
OL□□□66	Positive Software Limit	1 = 1 reference unit	√	√	–
OL□□□68	Negative Software Limit	1 = 1 reference unit	√	√	–
OL□□□6E	Reserved for system.	Reserved for system.	–	–	–
OL□□□70	User-specified SERVOPACK Parameter Set Value	Enter the value to set for the SERVOPACK parameter that is set with fixed parameter No. 44.	√	√	–
OW□□□68 to OW□□□7F*5	Command Buffers for SERVOPACK Transmission Reference Mode	This area is used for command data when MECHATROLINK Servo commands are specified directly.	√	√	–

*4. Do not set this parameter for linear motors.

*5. These parameters are used in SERVOPACK Transmission Reference Mode only.

B.3 Monitor Parameters

The following table lists the SVB, SVC, and SVR monitor parameters.

Refer to the following manual for details on individual monitor parameters.

 MP2000 Series SVA-01 Motion Module User's Manual (Manual No.: SIEP C880700 32)

 MP2000 Series Built-in SVB/SVB-01 Motion Module User's Manual (Manual No.: SIEP C880700 33)

 MP2000 Series SVC-01 Motion Module User's Manual (Manual No.: SIEP C880700 41)

Register Address	Name	Description	SVB	SVC	SVR
IW□□□00	RUN Status	Bit 0: Motion Operation Ready (Motion controller operation ready) 0: Motion operation not ready 1: Motion operation ready	√	√	√
		Bit 1: Running with Servo ON (Running (At servo on)) 0: Stopped, 1: Running with Servo ON	√	√	√
		Bit 2: System Busy 0: System not busy, 1: System busy	√	√	–
		Bit 3: Servo Ready 0: Servo not ready, 1: Servo ready	√	√	–
		Bit 4: Latch Mode 0: Latch detection request not received 1: Latch detection request received	√	√	–
		Bits 5 to F: Reserved for system.	–	–	–
IW□□□01	Out-of-range Parameter Number	Setting parameter: 0 and higher Fixed parameter: 1000 and higher	√	√	√
IL□□□02	Warnings	Bit 0: Excessive Deviation 0: In normal deviation range 1: Excessive deviation detected	√	√	–
		Bit 1: Setting Parameter Error (Set parameter error) 0: In setting range, 1: Outside setting range	√	√	√
		Bit 2: Fixed Parameter Error 0: In setting range, 1: Outside setting range	√	√	√
		Bit 3: SERVOPACK Error 0: No warning, 1: Warning	√	√	–
		Bit 4: Motion Command Setting Error (Motion command set error) 0: No command setting error 1: Command setting error	√	√	√
		Bit 5: Reserved for system.	√	–	–
		Bit 6: Positive Overtravel (Positive direction overtravel) 0: No positive overtravel 1: Positive overtravel occurred	√	√	–
	Bit 7: Negative Overtravel (Negative direction overtravel) 0: No negative overtravel 1: Negative overtravel occurred	√	√	–	
	Warnings	Bit 8: Servo ON Incomplete 0: Servo ON, 1: Servo ON incomplete	√	√	–
		Bit 9: SERVOPACK Communications Warning 0: Communications normal 1: Communications error detected	√	√	–
Bit A: SERVOPACK Stop Signal Active 0: There is no stop signal input 1: There is a stop signal input		√	√	–	
	Bits B to 1F: Reserved for system.	–	–	–	

Continued on next page.

Continued from previous page.

Register Address	Name	Description	SVB	SVC	SVR
IL□□□04 (Continued on next page.)	Alarms	Bit 0: SERVOPACK Error 0: No SERVOPACK alarm 1: SERVOPACK alarm occurred	√	√	–
		Bit 1: Positive Overtravel (Positive direction overtravel) 0: No positive overtravel 1: Positive overtravel occurred	√	√	–
		Bit 2: Negative Overtravel (Negative direction overtravel) 0: No negative overtravel 1: Negative overtravel occurred	√	√	–
		Bit 3: Positive Software Limit (Positive direction software limit) 0: Positive software limit not exceeded 1: Positive software limit exceeded	√	√	–
		Bit 4: Negative Software Limit (Negative direction software limit) 0: Negative software limit not exceeded 1: Negative software limit exceeded	√	√	–
		Bit 5: Servo OFF 0: Servo ON, 1: Servo OFF	√	√	√
		Bit 6: Positioning Time Exceeded (Positioning time over) 0: No timeout, 1: Timeout occurred	√	√	–
		Bit 7: Excessive Positioning Travel Distance (Excessive positioning moving amount) 0: Normal travel distance 1: Excessive travel distance	√	√	–
		Bit 8: Excessive Speed 0: Normal speed, 1: Excessive speed	√	√	–
		Bit 9: Excessive Deviation 0: Normal following deviation 1: Excessive deviation	√	√	–
		Bit A: Filter Type Change Error 0: No change error, 1: Change error occurred	√	√	–
		Bit B: Filter Time Constant Change Error 0: No change error, 1: Change error occurred	√	√	–
		Bit C: Reserved for system.	–	–	–
		Bit D: Zero Point Unset*1 (Zero point unsetting) 0: Zero point is not set 1: Zero point unset error occurred	√	√	–
		Bits E and F: Reserved for system.	–	–	–
		Bit 10: SERVOPACK Synchronized Communications Error (Servo Driver Synch. Comm. error) 0: No synchronized communications error 1: Synchronized communications error occurred	√	√	–
		Bit 11: SERVOPACK Communications Error 0: No consecutive synchronized communications errors 1: Consecutive synchronized communications errors occurred	√	√	–
Bit 12: SERVOPACK Communications Timeout Error 0: SERVOPACK command completed within the specified time 1: SERVOPACK command not completed within the specified time	√	√	–		

Continued on next page.

Continued from previous page.

Register Address	Name	Description	SVB	SVC	SVR
IL□□□04 (Continued from previous page.)	Alarms	Bit 13: Excessive Absolute Encoder Rotations* ¹ (Excessive ABS encoder rotations) 0: In valid range, 1: Outside valid range	√	√	–
		Bits 14 and 15: Reserved for system.	–	–	–
		Bit 16: Scan Setting Error 0: No scan setting error, 1: Scan setting error occurred	√	√	–
		Bits 17 to 1B: Reserved for system.	–	–	–
		Bit 1C: Cyclic Communications Initialization Incomplete 0: Initialization completed (default) 1: Initialization not completed	√	√	–
		Bit 1D: Detected SERVOPACK Model Error 0: Match, 1: Mismatch	√	√	–
		Bit 1E: Motor Type Setting Error 0: Match, 1: Mismatch	√	√	–
		Bit 1F: Connected Encoder Model Error 0: Match, 1: Mismatch	√	√	–
IL□□□06	–	Reserved for system.	–	–	–
IW□□□08	Motion Command Response Code	Same as OW□□□08 (motion commands).	√	√	√
IW□□□09	Motion Command Status	Bit 0: Command Execution Flag (BUSY) 0: READY (Completed), 1: BUSY (Processing)	√	√	√
		Bit 1: Command Hold Completed (HOLDL) 0: Command hold not completed 1: Command hold completed	√	√	√
		Bit 2: Reserved for system.	–	–	–
		Bit 3: Command Error End (FAIL) (Command error completed status) 0: Completed normally, 1: Completed with an error	√	√	√
		Bits 4 to 7: Reserved for system.	–	–	–
		Bit 8: Command Execution Completed (COMPLETE) 0: Normal execution not completed 1: Normal execution completed	√	√	√
		Bits 9 to F: Reserved for system.	–	–	–
IW□□□0A	Motion Sub-command Response Code	Same as OW□□□0A (Motion Subcommands).	√	√	√
IW□□□0B	Motion Sub-command Status	Bit 0: Command Execution Flag 0: READY (Completed), 1: BUSY (Processing)	√	√	√
		Bits 1 to 2: Reserved for system.	–	–	–
		Bit 3: Command Error End (Command error completed status) 0: Completed normally, 1: Completed with an error	√	√	√
		Bits 4 to 7: Reserved for system.	–	–	–
		Bit 8: Command Execution Completed 0: Normal execution not completed 1: Normal execution completed	√	√	√
		Bits 9 to F: Reserved for system.	–	–	–

Continued on next page.

*1. This parameter is not valid for linear motors.

Continued from previous page.

Register Address	Name	Description	SVB	SVC	SVR
IW□□□0C	Position Management Status	Bit 0: Distribution Completed (DEN) (Discharging completed) 0: Distributing pulses, 1: Distribution completed	√	√	√
		Bit 1: Positioning Completed (POSCOMP) 0: Outside positioning completed range 1: Within positioning completed range	√	√	√
		Bit 2: Latch Completed (LCOMP) 0: Latch not complete, 1: Latch completed	√	√	–
		Bit 3: Near Position (NEAR) 0: Outside near position range 1: Within near position range	√	√	√
		Bit 4: Zero Point Position (ZERO) 0: Outside zero point position range 1: Within zero point position range	√	√	√
		Bit 5: Zero Point Return/Setting Completed (ZRNC) (Zero point return [setting] completed) 0: Zero point return/setting not completed 1: Zero point return/setting completed	√	√	√
		Bit 6: Machine Locked (MLKL) (During machine lock) 0: Machine Lock Mode released, 1: Machine locked	√	√	–
		Bit 7: Reserved for system.	–	–	–
		Bit 8: Absolute Infinite-length Position Information Load Completed (ABSLDE) (ABS rotary pos. LOAD complete) 0: Load not complete, 1: Load completed	√	√	–
		Bit 9: POSMAX Turn Preset Completed (TPRSE)*1 (POSMAX turn preset complete) 0: Preset not completed, 1: Preset completed	√	√	√
		Bits A to F: Reserved for system.	–	–	–
IW□□□0D	–	Reserved for system.	–	–	–
IL□□□0E	Machine Coordinate System Target Position (TPOS)	1 = 1 reference unit	√	√	√
IL□□□10	Machine Coordinate System Calculated Position (CPOS)	1 = 1 reference unit	√	√	√
IL□□□12	Machine Coordinate System Reference Position (MPOS)	1 = 1 reference unit	√	√	√
IL□□□14	32-bit DPOS (DPOS)	1 = 1 reference unit	√	√	√
IL□□□16	Machine Coordinate System Feedback Position (APOS)	1 = 1 reference unit	√	√	√
IL□□□18	Machine Coordinate System Latch Position (LPOS)	1 = 1 reference unit	√	√	–

Continued on next page.

*1. This bit is not valid for linear motors.

Continued from previous page.

Register Address	Name	Description	SVB	SVC	SVR
IL□□□1A	Position Deviation (PERR)	1 = 1 reference unit	√	√	–
IL□□□1C	Target Position Increment Monitor (PDV) (Target position difference monitor)	1 = 1 reference unit	–	–	√
IL□□□1E*1	Number of POSMAX Turns	1 = 1 turn	√	√	√
IL□□□20	Speed Reference Output Monitor	pulse/s	√	√	–
IL□□□22 to IL□□□27	–	Reserved for system.	–	–	–
IL□□□28	M-III Servo Command Input Signal Monitor	Reports the signal information that is input to the MECHATROLINK-III.	√	√	–
IL□□□2A	M-III Servo Command Status	Reports the Servo command information that is input to MECHATROLINK-III.	√	√	–
IW□□□2C	M-III Command Status	Bit 0: Drive Alarm (D_ALM) (Drive Alarm Occurrence) Bit 1: Drive Warning (D_WAR) (Drive Warning Occurrence) Bit 2: Command Ready (CMDRDY) Bit 3: Alarm Clear Execution Completed (ALM_CLR_CMP) (Alarm Clear Execution Completion) Bits 4 and 5: Reserved for system. Bits 6 and 7: Echo-back of Command ID (RCMD_ID) Bits 8 to B: Command Error Status (CMD_ALM) (Command Error) Bits C to F: Communications Error Status (COMM_ALM)	√	√	–
IW□□□2D	SERVOPACK Alarm Code	Reports the alarm code from the SERVOPACK.	√	√	–
IW□□□2E	–	Reserved for system.	–	–	–
IW□□□2F	SERVOPACK User Monitor Information	Bits 0 to 3: Monitor 1 (Cannot be set.) Bits 4 to 7: Monitor 2 Bits 8 to B: Monitor 3 (Cannot be set.) Bits C to F: Monitor 4	√	√	–
IL□□□30	SERVOPACK User Monitor 2	Reports the result of the selected monitor item.	√	√	–
IL□□□32	SERVOPACK User Monitor 3	Reserved for system.	–	–	–
IL□□□34	SERVOPACK User Monitor 4	Reports the result of the selected monitor item.	√	√	–
IW□□□36	SERVOPACK Parameter Number	Reports the number of the target parameter.	√	√	–
IW□□□37	Auxiliary SERVOPACK Parameter Number	Reports the number of the target parameter.	√	√	–

Continued on next page.

*1. This parameter is not valid for linear motors.

Continued from previous page.

Register Address	Name	Description	SVB	SVC	SVR
IL□□□38	SERVOPACK Parameter Read Data	Reports the setting of the read parameter.	√	√	–
IL□□□3A	Auxiliary SERVOPACK Parameter Read Data	Reports the setting of the read parameter.	√	√	–
IW□□□3C to IW□□□3E	–	Reserved for system.	–	–	–
IW□□□3F	Motor Type	Reports the type of the connected motor. 0: Rotary motor, 1: Linear motor	√	√	–
IL□□□40	Feedback Speed	The unit is set in bits 0 to 3 (Speed Unit Selection) of OW□□□03.	√	√	√
IL□□□42	Torque/Force Reference Monitor	The unit is set in bits C to F (Torque Unit Selection) of OW□□□03.	√	√	√
IW□□□44 to IW□□□55	–	Reserved for system.	–	–	–
IL□□□56	Fixed Parameter Monitor	Stores the execution results of the FIXPRM_RD motion subcommand.	√	√	√
IW□□□58 to IW□□□5A	–	Reserved for system.	–	–	–
IW□□□5B	Device Information Monitor Code	00 hex: Disabled 01 hex: Vendor ID code 02 hex: Device code 03 hex: Device version 04 hex: Device information file version 05 hex: Serial number	√	√	–
IL□□□5C	–	Reserved for system.	–	–	–
IL□□□5E	Power OFF Encoder Position (Encoder position when power is off) (Lower 2 Words)	1 = 1 pulse	√	√	–
IL□□□60	Power OFF Encoder Position (Encoder position when power is off) (Upper 2 Words)	1 = 1 pulse	√	√	–
IL□□□62	Power OFF Pulse Position (Pulse position when power is off) (Lower 2 Words)	1 = 1 pulse	√	√	–
IL□□□64	Power OFF Pulse Position (Pulse position when power is off) (Upper 2 Words)	1 = 1 pulse	√	√	–

Continued on next page.

Continued from previous page.

Register Address	Name	Description	SVB	SVC	SVR
IW□□□66 to IW□□□6F	–	Reserved for system.	–	–	–
IW□□□70 to IW□□□7F	Device Information Monitor Data	Reports the information that was read with the INF_RD subcommand.	√	√	–
IW□□□68 to IW□□□7F*2	Response Buffers for SERVOPACK Transmission Reference Mode	Stores MECHATROLINK Servo responses.	√	√	–

*2. These parameters are used in SERVOPACK Transmission Reference Mode only.

Index

A

alarm code details - - - - - 5-27

alarm monitor - - - - - 5-25

B

background - - - - - 4-7

Battery Installation - - - - - 2-8

Battery replacement - - - - - 2-9

C

checking for multiple coils - - - - - 5-17

combinations

 MP2000-series products - - - - - 1-2

connection

 connecting the power supply and other devices - - 2-26

 connecting the power supply connector- - - - - 2-21

 connecting the RLY OUT connector - - - - - 2-25

 project link connection- - - - - 3-25

creating a group definition - - - - - 4-52

creating programs

 ladder programs - - - - - 4-48

 motion main programs - - - - - 4-53

 motion subprogram - - - - - 4-55

 sequence main program- - - - - 4-57

 sequence subprogram- - - - - 4-58

cross reference

 ladder program - - - - - 5-14

 motion and sequence programs - - - - - 5-25

D

data transfer

 with the MPE720 - - - - - 4-60

 without the MPE720 - - - - - 4-69

debugging

 ladder programs - - - - - 5-3

 motion program - - - - - 5-21

 sequence program - - - - - 5-21

DWG.A- - - - - 4-5

DWG.H- - - - - 4-5

DWG.I - - - - - 4-5

DWG.L - - - - - 4-5

E

enabling and disabling a program- - - - - 5-20

Ethernet connection preparation - - - - - 3-20

F

forcing coils ON and OFF - - - - - 5-17

I

installation

 DIN rail mounting - - - - - 2-2

 screw mounting - - - - - 2-2

L

ladder programs - - - - - 4-3

 creating - - - - - 4-48

 debugging - - - - - 5-3

list of fixed parameters - - - - - B-2

list of monitor parameters - - - - - B-13

list of setting parameters - - - - - B-5

M

M-EXECUTOR functionality - - - - - 4-23

monitoring

 axis alarm monitor - - - - - 5-34

 axis monitor - - - - - 5-30

 realtime tracing- - - - - 5-39

 XY trace- - - - - 5-61

motion parameters

 list of fixed parameters - - - - - B-2

 list of monitor parameters- - - - - B-13

 list of setting parameters - - - - - B-5

motion programs - - - - - 4-9

 creating - - - - - 4-52

 debugging - - - - - 5-21

MPE720 Ver. 7

 installation - - - - - 3-3

 project link connection - - - - - 3-25

 transferring data - - - - - 4-60

O

online security - - - - - 6-10

 changing - - - - - 6-12

 changing the security key- - - - - 6-14

 deleting - - - - - 6-13

 setting- - - - - 6-11

Optional Modules

 installation - - - - - 2-5

 replacing and adding - - - - - 2-6

P

program security - - - - - 6-7

 changing a password - - - - - 6-8

 deleting a password - - - - - 6-8

 setting a password - - - - - 6-7

project file

 creating a project file - - - - - 3-14

 setting a project password - - - - - 3-17

- project file security - - - - - 6-2
 creating or changing a password - - - - - 6-2
 deleting a password - - - - - 6-3
 setting a project password - - - - - 6-2
 setting the default user - - - - - 6-4
 user management - - - - - 6-4
 project link connection - - - - - -3-25
- R**
- reading
 from a project file - - - - - -4-64
 from the Machine Controller - - - - - -4-63
 register list - - - - - 5-4
 registers - - - - - -4-38
- S**
- saving to flash memory - - - - - -4-65
 scan time setting - - - - - -3-52
 scheduling the execution of high-speed and low-speed
 scan process drawings - - - - - 4-7
 searching and replacing in programs
 ladder programs - - - - - 5-8
 motion and sequence programs - - - - - -5-24
 searching and replacing in project files
 ladder programs - - - - - -5-10
 motion and sequence programs - - - - - -5-24
 security
 online security - - - - - -6-10
 program security - - - - - 6-7
 project file security - - - - - 6-2
 self configuration
 data that is updated automatically during self
 configuration - - - - - -3-29
 parameters written during self configuration - - - - - -3-40
 sequence programs - - - - - -4-21
 creating - - - - - -4-57
 debugging - - - - - -5-21
 setting the high-speed and low-speed times - - - - - 4-7
 setup flow - - - - - 3-2
 system configuration - - - - - 1-4
- T**
- test run - - - - - -3-54
 tuning - - - - - -5-63
 using DriveWizard Plus (when using an Inverter) - - - - - -5-63
 using SigmaWin+ (when using a Servo) - - - - - -5-63
- U**
- user program types - - - - - 4-3
 ladder programs - - - - - 4-3
 motion programs - - - - - 4-9
 sequence programs - - - - - -4-21
 using a CF card (MP2200 only)
 with the MPE720 - - - - - -4-66
 without the MPE720 - - - - - -4-69
- using the MPLoad Marker - - - - - 4-74
 using the MPLoader - - - - - 4-72
- V**
- viewing a called program - - - - - 5-20
 viewing a motion subprogram - - - - - 5-25
- W**
- watch - - - - - -5-7, 5-24
 writing
 to a project file - - - - - 4-62
 to the Machine Controller - - - - - 4-61

Revision History

The date of publication, revision number, and web revision number are given at the bottom right of the back cover. Refer to the following example.

MANUAL NO. SIEP C880732 14A <0>-1

Published in Japan April 2016

WEB revision number
Revision number
Date of publication

Date of Publication	Rev. No.	WEB Rev. No.	Section	Revised Contents
April 2020	<4>	1	Preface, 2.1.6, 2.2.3, 3.6.1	Partly revised.
			Back cover	Revision: Address
April 2019	<4>	0	All chapters	Partly revised.
			Back cover	Revision: Address
February 2018	<3>	1	A.2	Addition: EN 61131-2 Zone B
February 2018		0	A.1.3	Revision: Noise Resistance
January 2018	<2>	0	A.1.3	Revision: Noise Resistance
			Back cover	Revision: Address
December 2016	<1>	0	A.1	Revision: Combined A.1 and A.2.
			A.2	Addition: EMC installation conditions
April 2016	<0>	1	Front cover	Revision: Format
			2.2.5	Revision: Procedure to set MECHATROLINK-III station address
			Back cover	Revision: Address and format
January 2015	-	-	-	First edition

Machine Controller MP2000 Series

Machine Controller System

SETUP MANUAL

IRUMA BUSINESS CENTER (SOLUTION CENTER)

480, Kamifujisawa, Iruma, Saitama, 358-8555, Japan
Phone: +81-4-2962-5151 Fax: +81-4-2962-6138
www.yaskawa.co.jp

YASKAWA AMERICA, INC.

2121, Norman Drive South, Waukegan, IL 60085, U.S.A.
Phone: +1-800-YASKAWA (927-5292) or +1-847-887-7000 Fax: +1-847-887-7310
www.yaskawa.com

YASKAWA ELÉTRICO DO BRASIL LTDA.

777, Avenida Piraporinha, Diadema, São Paulo, 09950-000, Brasil
Phone: +55-11-3585-1100 Fax: +55-11-3585-1187
www.yaskawa.com.br

YASKAWA EUROPE GmbH

Hauptstraße 185, 65760 Eschborn, Germany
Phone: +49-6196-569-300 Fax: +49-6196-569-398
www.yaskawa.eu.com E-mail: info@yaskawa.eu.com

YASKAWA ELECTRIC KOREA CORPORATION

35F, Three IFC, 10 Gukjegeumyung-ro, Yeongdeungpo-gu, Seoul, 07326, Korea
Phone: +82-2-784-7844 Fax: +82-2-784-8495
www.yaskawa.co.kr

YASKAWA ASIA PACIFIC PTE. LTD.

30A, Kallang Place, #06-01, 339213, Singapore
Phone: +65-6282-3003 Fax: +65-6289-3003
www.yaskawa.com.sg

YASKAWA ELECTRIC (THAILAND) CO., LTD.

59, 1F-5F, Flourish Building, Soi Ratchadapisek 18, Ratchadapisek Road, Huaykwang, Bangkok, 10310, Thailand
Phone: +66-2-017-0099 Fax: +66-2-017-0799
www.yaskawa.co.th

YASKAWA ELECTRIC (CHINA) CO., LTD.

22F, Link Square 1, No.222, Hubin Road, Shanghai, 200021, China
Phone: +86-21-5385-2200 Fax: +86-21-5385-3299
www.yaskawa.com.cn

YASKAWA ELECTRIC (CHINA) CO., LTD. BEIJING OFFICE

Room 1011, Tower W3 Oriental Plaza, No.1, East Chang An Avenue,
Dong Cheng District, Beijing, 100738, China
Phone: +86-10-8518-4086 Fax: +86-10-8518-4082

YASKAWA ELECTRIC TAIWAN CORPORATION

12F, No. 207, Section 3, Beishin Road, Shindian District, New Taipei City 23143, Taiwan
Phone: +886-2-8913-1333 Fax: +886-2-8913-1513 or +886-2-8913-1519
www.yaskawa.com.tw

YASKAWA

YASKAWA ELECTRIC CORPORATION

In the event that the end user of this product is to be the military and said product is to be employed in any weapons systems or the manufacture thereof, the export will fall under the relevant regulations as stipulated in the Foreign Exchange and Foreign Trade Regulations. Therefore, be sure to follow all procedures and submit all relevant documentation according to any and all rules, regulations and laws that may apply.

Specifications are subject to change without notice for ongoing product modifications and improvements.

© 2015 YASKAWA ELECTRIC CORPORATION

MANUAL NO. SIEP C880732 14C <4>-1

Published in Japan April 2020

19-10-16

Original instructions